

Lucerne University of
Applied Sciences and Arts

**HOCHSCHULE
LUZERN**

Technik & Architektur



PinCH

An analysis and design tool for process integration

VERSION 3.2

USER MANUAL

Created on 31.08.2020

Lucerne School of Engineering and Architecture
CC Thermal Energy Systems and Process Engineering
Technikumstrasse 21
CH-6048 Horw, Switzerland

www.pinch-analyse.ch
pinch@hslu.ch

**PinCH is supported by the Swiss Federal Office of Energy (SFOE).
Additional support for Version 2.0 was given by the Swiss Private Sector
Energy Agency (Energie-Agentur der Wirtschaft - EnAW)**

Preface

PinCH is a user-friendly software for the practical implementation of pinch-analysis in industry. The software has been developed at the Competence Center Thermal Energy Systems and Process Engineering at the Lucerne School of Engineering and Architecture. The development team is very thankful to the Swiss Federal Office of Energy (SFOE) and the Swiss Private Sector Energy Agency (EnAW) for their financial support. In addition, the team thanks the experts from Weisskopf Partner GmbH, Brunner Energieberatung GmbH and HEIG-VD for the valuable technical advice and support in writing this documentation.

Information about the software PinCH including the current versions of the software and manual is available at www.pinch-analyse.ch.

Copyright © 2020 Hochschule Luzern

All rights reserved worldwide. No part of this publication may be reproduced, transmitted, transcribed, stored in a retrieval system, or translated into any language in any form by any means, without written permission from Hochschule Luzern.

Trademark Information:

Microsoft, Windows and Excel are registered trademarks of Microsoft Corporation. Matlab is a registered trademark of Mathworks.

Summary

The use of energy in the world today and in the future is important for governments and citizens alike due to its central role in everyday life. Without access to affordable and highly concentrated sources of energy much of today's economic and innovation progress could be severely affected. As a result, there are concerns related to the increasing shortage of resources presently used for meeting the energy demands of the world's economies. In addition, CO₂ emissions targets are legislated with the goal of reducing the amount of CO₂ and other greenhouse gases emitted. Nevertheless, the world's economies require energy to meet the everyday needs of citizens and provide opportunities for new innovation and economic growth in both western and developing nations. One of the keys to meeting this challenge is to improve energy efficiency throughout the industrial infrastructure. This approach has the combined effect of reducing energy demand as well as CO₂ emissions. The Swiss Federal Office of Energy (SFOE) has estimated that a 30 - 50% reduction in energy needs of domestic industrial processes can be achieved through improved efficiency and energy utilization. Better energy efficiency is a way to the future.

A common method used for improving industrial energy efficiency is pinch analysis method which is part of the more generalized and broader area of process integration. It plays a central role in the integrated or holistic approach in process synthesis and design and has been shown to provide significant improvements in the energy utilization of industrial facilities of various levels of complexity and size. The method is based on a relatively practical interpretation of the second law of thermodynamics and places a considerable amount of responsibility on the user to fully understand the process they are trying to optimize. This action in itself provides a strong basis for the adoption of such a technology as the design engineer speaks in terms of his or her process on a practical concrete level of understanding. The results from a pinch analysis study provide the thermodynamically feasible targets for the industrial process being studied. The method seeks to distinguish between avoidable and inevitable losses. Therefore, given an optimum economic and energy trade-off the energy targets encompassing only the inevitable losses can be calculated. These targets provide a powerful incentive in the design or retrofitting project phase to ensure the maximum amount of energy is recovered leading to the minimum amount of required external energy at the most economic constraint.

Due to the large amount of information and details that can arise during an analysis for medium to large processes, a computer based tool is typically needed to support a pinch analysis study. Today several commercial applications exist; however, one version of a pinch analysis tool was developed in the Ecole Polytechnique Fédérale de Lausanne (EPFL) in the early 1990's ("PinchLENI", Prof. Dr. Daniel Favrat, Laboratoire d'énergétique industrielle LENI). This tool has allowed students and engineers to learn and apply the method in the praxis successfully. PinchLENI has been used successfully over the years, but the decision was made to upgrade the entire code base to new technology and include additional new features within the field of process integration that were not developed in the original software. This new software is called **PinCH** and is documented in this user manual. PinCH maintains the user friendliness of its predecessor in allowing the design engineer to easily create the stream table for the process in question followed by targeting analysis to determine the ΔT_{min} , pinch temperature and associated thermodynamically feasible minimum utility requirements. These targets provide the basis for the final project stage of heat exchanger network design and synthesis. The latest version is PinCH 3.2. This version extends upon the previous releases PinCH by providing new support for the analysis of time dependent processes requiring thermal heat storage. The software provides a systematic approach to analyzing such processes to produce a cost effective and practical conceptual design. In addition, significant enhancements and support have been added to the direct heat recovery HEN Grid to enable the user to design cost optimal networks for multiple operating cases or batch processes. Finally, to help support the user in data extraction of the process heating and cooling requirements, a new Excel based E-Module (Energy Module) tool has been added.

In conclusion, the PinCH software is a powerful simulation tool focussed on the optimization of industrial processes as its main goal. The realization of this goal will allow the continued promotion of the pinch analysis method enabling progress and leadership in the area of process integration and a more holistic system design approach to optimizing industrial energy use.

Contents

1	Welcome to PinCH	1
1.1	Introducing PinCH	1
1.2	About This Manual	2
1.3	What Features Are In PinCH	2
2	Installing And Upgrading PinCH	5
2.1	PinCH Program Requirements	5
2.2	PinCH Local Installation	6
2.3	Upgrading to a Newer Version	8
2.4	Using PinCH 3.2 on a Network	9
2.5	Update a Locally Installed Time Period License For Leasing	11
2.6	Uninstalling PinCH	12
3	PinCH Guided Tour	13
3.1	PinCH Processing Steps	13
3.2	Major Graphical Components of PinCH	16
3.3	Process Types Modeling	19
3.3.1	Single Process Continuous	20
3.3.2	Multiple Processes, Continuous And Synchronous	20
3.3.3	Multiple Processes, Continuous, Not Overlapped	21
3.3.4	Multiple Processes, Continuous, Overlapped	22
3.3.5	Single Process, Multiple Operating Cases	22
3.3.6	Single Process, Batch	24

4	Using the Process Stream Table	25
4.1	Importance of Proper Data Extraction	25
4.2	The Stream Table (Process Requirements)	26
4.3	Defining Streams	28
4.4	Configuring Fluid Types	31
4.5	Configuring Utility Streams	33
4.6	Configuring Soft Streams	34
4.7	Importing and Exporting	34
5	E-Modules (Energy Modules)	37
5.1	Introduction	37
5.1.1	System Requirements	38
5.2	Obtaining E-Modules	38
5.3	Getting Started	41
5.3.1	Brief Overview	41
5.3.2	Symbols and Coloring	42
5.3.3	Abbreviations	44
5.3.4	Document Information - Header	45
5.3.5	Standard Blocks and Symbols	46
5.3.6	Stream Table	47
5.4	Using E-Modules with PinCH	49
5.4.1	Basics	49
5.4.2	Opening and Using E-Modules	49
5.4.3	Saving E-Modules	50
5.4.4	Exporting E-Modules Stream Table to PinCH	50
5.5	PinCH/E-Module Fluid Calculation Interface	51
5.5.1	Uploading PinCH Add-Ins to Excel	51
5.5.2	Using the Add-In Functions	51

6	Configuring the Project	53
6.1	Introduction	53
6.2	How to Create and Configure Equipment	54
6.3	How to Create Processes, Multiple Operating Cases Group and Assign Streams	55
6.4	How to Create and Configure Operating Case Schedules	57
6.5	How to Create and Configure Global Economic Data	61
7	Analyzing Single Continuous Processes	63
7.1	Introduction	63
7.2	How to Create and Configure a Target Group	64
7.3	How to Create a Target Result	65
7.4	How to Manage Targeting Results	67
7.5	Analyzing Results	70
7.6	Targeting Analysis Support Tools	76
8	Analyzing Multiple Operating Cases	79
8.1	Introduction	79
8.2	How to Schedule Multiple Operating Cases	80
8.2.1	Standard Multiple Operating Cases	80
8.2.2	Semi-Continuous Processes and Multiple Operating Cases	82
8.2.3	Multiple Operating Cases Groups	84
8.3	How to Create and Prepare a Target Group	85
8.4	Simplify Energy Targets - Energy Target Analysis	85
8.5	How to Create and Analyze Target Results	91
8.5.1	Separate Design Target Results	96
8.5.2	Conventional and Resequencing Design Target Results	96
8.6	Multiple Operating Cases – Analysis Support Tools	98

9	Analyzing Single Product Batch Processes - Direct Heat Recovery	101
9.1	Introduction	101
9.2	How to Schedule a Batch Process	102
9.2.1	Scheduling Stream Existence Times (Process Stream Table)	102
9.2.2	Scheduling the Single Batch Process (Operating Cases Schedules)	102
9.3	How to Create and Prepare a Target Group	105
9.4	Simplify Energy Targets - Energy Target Analysis	106
9.5	How to Create and Analyze Target Results	107
9.5.1	Separate Design Target Results	111
9.5.2	Conventional and Resequence Design Target Results	111
9.6	Single Product Batch Process Analysis Support Tools	113
10	Analyzing Single Product Batch Processes - Indirect Heat Recovery	117
10.1	Introduction	117
10.2	How to Create and Prepare a Target Group	118
10.3	How to Create and Analyze Target Results	119
10.3.1	Indirect Heat Recovery Target Results	120
10.3.2	Heat Exchanger and Storage Network Schema	130
10.3.3	Special Considerations with Shared Equipment	131
10.4	Indirect Heat Recovery Analysis Support Tools	132
11	Integrate Energy Conversion Units	135
11.1	Introduction	135
11.2	Economic Calculations	135
11.3	ECU Types	137
11.3.1	Heat Pump	137
11.3.2	Internal Combustion Engine	141

11.3.3 Mechanical Vapour Recompression	143
11.3.4 Thermal Vapour Recompression	146
11.3.5 Organic Rankine Cycle	149
11.4 How to Integrate an ECU	153
12 Turn Saving Opportunities into HENs	155
12.1 Introduction	155
12.2 How to Create a HEN Grid	158
12.3 Adding an Heat Exchanger	159
12.4 Splitting and Merging	161
12.5 Analyzing Results	164
12.6 HEN Design Support Tools	166
13 Menu Items, Keyboard Shortcuts and the Workbench	173
13.1 Menus Items and Keyboard Shortcuts	173
13.2 Keyboard Shortcuts - Stream Table	177
13.3 Keyboard Shortcuts - HEN Grid	178
13.4 Workbench	178
13.4.1 Dockable Windows	178
13.4.2 Properties Window	179
13.4.3 Explorer Nodes	179
14 List of Symbols And Acronyms	181
14.1 Symbols	181
14.2 Acronyms	183
15 Bibliography	185

A	Appendix	A1
A.1	Area And Number Of Units	A2
A.2	Heat Pump Energy Conversion Unit	A3
A.3	Internal Combustion Engine Energy Conversion Unit	A5
A.4	Mechanical Vapour Recompression Energy Conversion Unit	A7
A.5	Thermal Vapour Recompression Energy Conversion Unit	A9
A.6	Organic Rankine Cycle Energy Conversion Unit	A11
A.7	Add-In Functions and Excel “What-If-Analysis” and “Solver” Tools	A15
A.7.1	PinCH Add-In Functions	A15
A.7.2	Excel “What-If-Analysis” and “Solver” Tools	A18
A.8	Developing Own E-Modules	A23
A.8.1	Preliminary to E-Module Development	A23
A.8.2	Standardized Design	A27
A.8.3	Development Procedure	A32
A.8.4	Standard Elements	A33
A.8.5	Standard Appearance	A36
A.8.6	Standard Naming	A39
A.8.7	Standard Calculations	A40
A.8.8	Standard Stream Table	A43
A.8.9	Protection	A45
A.8.10	Files and Printing	A45
A.8.11	Quality Management	A46
A.9	Multiple Operating Cases and Batch Supertargeting	A53
A.10	Single Batch Product Scheduling and EROP Details	A60
A.11	Indirect Source and Sink Profile	A65
A.11.1	Constructing ISSPs	A66
A.11.2	Thermal Energy Storage Design	A71

Chapter 1

Welcome to PinCH

1.1 Introducing PinCH

Welcome to PinCH - a complete solution for energy analysis of industrial processes. To help promote the use of the pinch analysis method, the software tool PinCH (CH also stands for the Latin name “Confoederatio Helvetic”, i.e. Switzerland) was developed, which provides a sound basis for the application and support of the pinch method and process integration.

- PinCH is sophisticated analysis software that supports process integration studies focussed on the pinch analysis method.
- PinCH is a tool that supports energy optimization analysis for continuous, semi-continuous and batch processes.
- PinCH is a framework for handling multiple scenarios and process structures in targeting calculations.
- PinCH is a dynamic and powerful heat exchanger and storage network design tool.

See “What Features are in PinCH” for a list of the features included in this release of PinCH.

For the latest release information, please go to: www.pinch-analyse.ch

1.2 About This Manual

This manual assumes that you know how to use Microsoft Windows operating system, Microsoft Excel, a word processor and the computer mouse. For help on these topics, consult the associated user manual or online help.

Within the PinCH program itself are several ways to execute commands. Primarily the program is context menu driven based on right clicking the mouse on specific, context-sensitive, text fields. In addition, there is an on-line help system as well as a main menu and standard keyboard shortcuts available on the workbench.

Note: This user manual will be periodically updated. Please check the PinCH website for the latest version at www.pinch-analyse.ch.

1.3 What Features Are In PinCH

PinCH provides for the following main capabilities effective for energy optimization of industrial processes:

- Analysis of continuous, and semi-continuous processes for direct heat recovery
- Analysis of batch processes for direct as well as indirect heat recovery
- Optimization of utility systems
- Integration of heat pumps, combined heat and power (CHP) systems, mechanical vapour recompression units, etc.
- Design of heat exchanger and storage networks

The software also provides some of the following key functionality to support the optimization:

- Coupling of several processes (Process Management)
- Dynamic degree of freedom analysis stream table capabilities
- Flexible functions for investment and energy costs

-
- Technical and economic case studies (Scenario Management)
 - Current state analysis of processes and heat exchanger networks
 - Graphical design of heat exchanger and storage networks
 - Physical property data for refrigerants, water/steam and humid air systems based on Coolprop
 - Comprehensive data import/export capabilities
 - Carnot curves for exergy analysis
 - E-Modules to support process understanding and data extraction of common thermal energy unit operations or processes

And much more!

Chapter 2

Installing And Upgrading PinCH

2.1 PinCH Program Requirements

Please read this section before proceeding with the installation.

PinCH can be installed as a trial version that will run in a limited capacity for a short trial period. The trial can be upgraded to a fully purchased version upon request. Please visit our website for the latest pricing information at www.pinch-analyse.ch. In addition, information on how to obtain PinCH via a download is available on the website.

System Requirements:

In order to use the PinCH software, the **Microsoft.Net Framework 4.5** must be installed. Administrator rights are needed in order to do so and may require the assistance of your information technology department to complete the install. PinCH runs under the following operating systems:

- Windows 7 (32- or 64-bit versions)
- Windows 8 (32- or 64-bit versions)
- Windows 10 (32- or 64-bit versions)

Hardware Requirements:

- Processor: 2.6 GHz Pentium processor or equivalent (Recommended)
- RAM: 4096 MB (Recommended)
- Hard Disk: Up to 50 MB of available space may be required
- Display: 1680 x 1050 high colour, 32-bit (Recommended)
- Internet connection (Software activation)

2.2 PinCH Local Installation

Follow these instructions to install the PinCH program locally as a stand-alone single seat license.

- ⇒ If you are upgrading to a newer version, please see “Upgrading To A Newer Version”.
- ⇒ Please see “Using PinCH 3.2 on a Network” (section 2.4) for information about using PinCH on a network and the separate document “Network Installation Guide” for details of how to install and configure the network license manager.

PinCH is available in two versions - A free trial and a full purchased version. **Note:** Please ensure you have full administrator rights in order to be able to install the PinCH software. These rights are particularly important for the versions of the Windows operating system currently supported.

To install PinCH:

1. Login to the machine with administrator rights or as a user with program installation privileges.
2. Ensure you have obtained the most recent version of PinCH by checking for latest information on www.pinch-analyse.ch.
3. Unzip the compressed installer file to your computer and double click the installer file to start the PinCH setup program.

4. Follow the instructions on the screen to complete the installation. Use the appropriate buttons on each wizard dialog as follows:
 - a. Licence Agreement: Review the licensing agreement and choose to accept the agreement or not. If accepted, then select **Install** to begin the installation.
 - b. Installing PinCH 3.2: Installation will proceed and the necessary changes will be completed. Be sure to accept the Windows security dialog to allow installation to proceed.
 - c. Installation Complete: Press Finish to close the wizard.
5. After installing PinCH start the program and the Trial/Activation dialog will appear.
6. Select Continue to begin to use the trial version of PinCH immediately.
7. To purchase a version of PinCH, please go to our website for latest pricing information at www.pinch-analyse.ch.
8. If you have purchased a version of PinCH 3.2, then you will receive a Product Key by E-Mail. Select the Activate button and paste a copy of the Product Key into the entry box and select activate (see Fig. 2.1). PinCH will automatically activate the license directly and no other action is required.

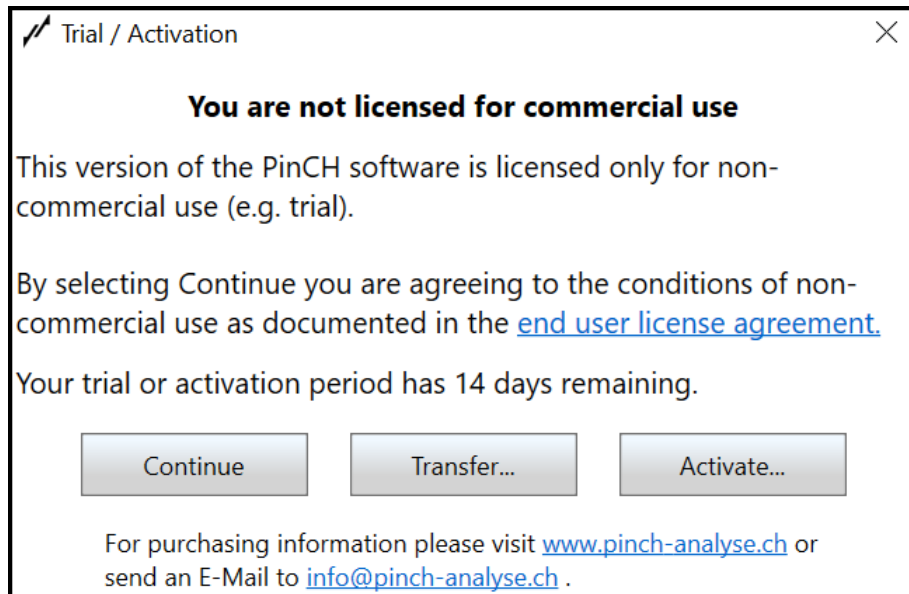

Fig. 2.1: Trial / Activation dialog

Note: Please ensure you have access to the internet to allow the automatic activation to occur as shown in Fig. 2.2. Off-line activation is not supported.

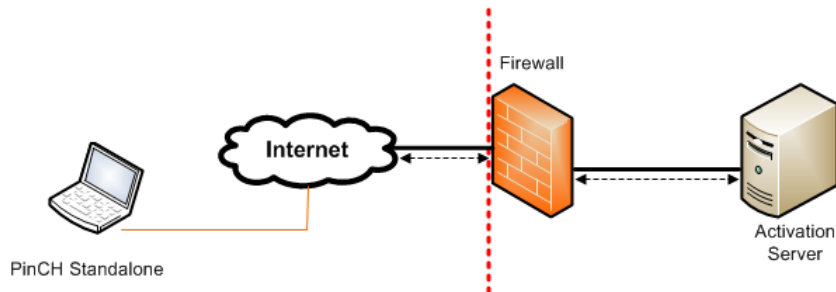

Fig. 2.2: Standalone installation activation

2.3 Upgrading to a Newer Version

Before upgrading PinCH 3.2, back up any project files or custom layout file that you have created. We recommend that you uninstall any previous version of PinCH 3.2 that has been installed before upgrading. However, if during the setup an earlier version is detected then PinCH will automatically remove the program.

Install the upgrade just as you would a new install as detailed in section

2.2 “PinCH Local Installation”. The existing valid PinCH 3.2 license will be recognized and used.

2.4 Using PinCH 3.2 on a Network

PinCH 3.2 can be used in a networked environment as shown in Fig. 2.3. Your IT department will be responsible to install and configure the network licenses on a dedicated license server. As a standard user you can simply start PinCH 3.2 when connected to the local network and the licensing server will be found automatically if in the same subnet.

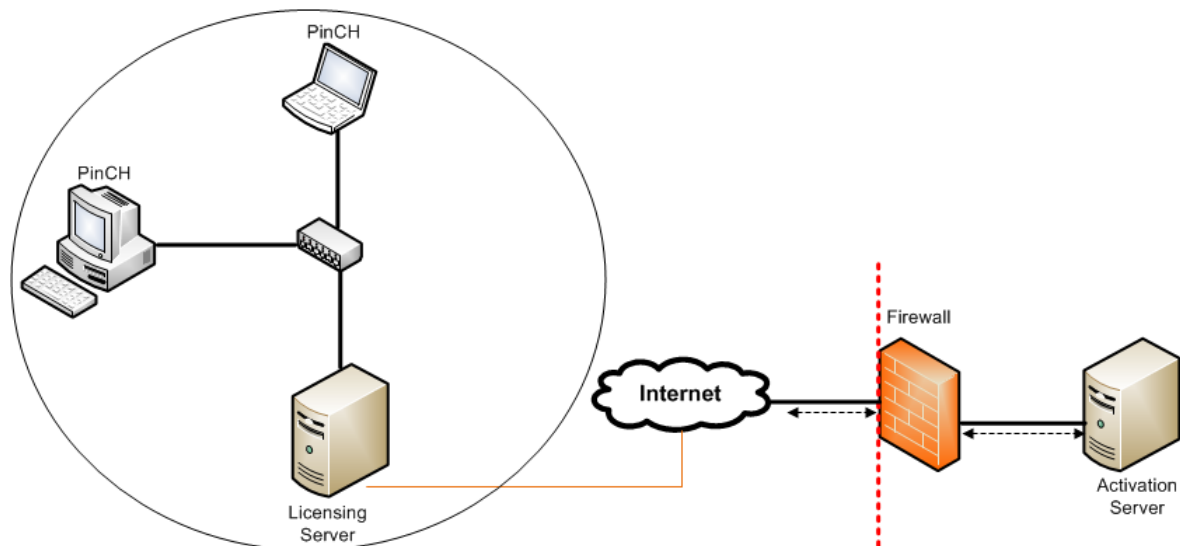

Fig. 2.3: Simplified network diagram showing IT components when in same subnet

In the case of having the licensing server on a different subnet as the one where the PinCH software is installed (e.g. multiple broadcast domains as often seen in larger companies), the license server can be accessed by setting the host name (or IP address) of the licensing server in the Sentinel Admin Control Center that is automatically installed on each client installed version of PinCH. To configure a PinCH client installation to access a network license server on another subnet do the following:

- Obtain the license server host name or IP address from your IT department.

- Select the button **Activate...**
- Enter the host name (License Server Name) or IP address of the LM server in the text box (See Fig. 2.4).
- Press **Activate**.

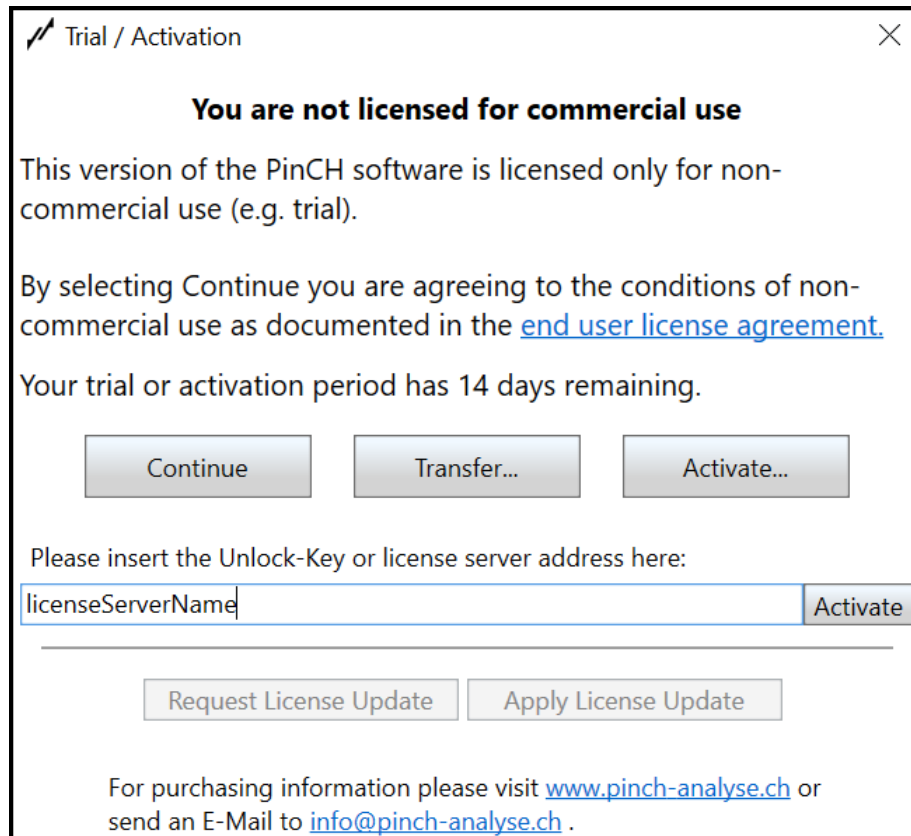

Fig. 2.4: Trial / Activation dialog showing the entry of the License Server name

2.5 Update a Locally Installed Time Period License For Leasing

When leasing the PinCH software a limited time period license is supplied for local installations. In order to update the license once the time period has expired or the decision is made to extend the time period, then the license can be easily update in the PinCH software itself by doing the following:

- Option 1: If the time period license has expired then restart PinCH and select **Activate** button on the Trial / Activation dialog.
- Option 2: If the time period license is still active then select menu item File -> Settings and then the tab **Licensing**. Next select the button **Activate / Update License**.
- Select the button **Request License Update** (see Fig. 2.5).
- Send the generated **C2V file** to pinch@hslu.ch for direct processing by PinCH management personnel.
- Once you received the V2C license update file save it in a convenient location on your computer.
- Select the **Apply License Update** (see Fig. 2.5) button and choose the saved V2C file.
- Select the **Open** button to apply the update.

Note: In certain circumstances it may be required to complete the update externally using a separate remote update service (see PinCH 3.2 Installation User Manual for more information).

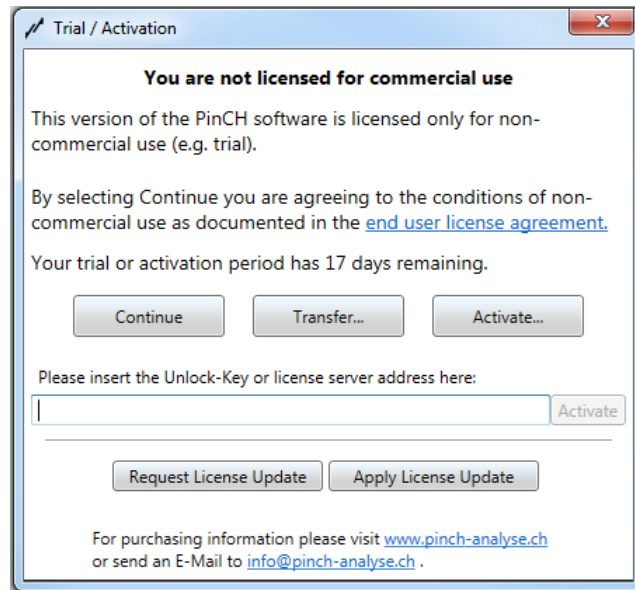

Fig. 2.5: Trial / Activation dialog showing the active **Request License Update** and **Apply License Update** buttons needed to update and active license

2.6 Uninstalling PinCH

Before uninstalling PinCH, back up any project files or the custom layout file that you have created.

To uninstall PinCH:

1. Login to the machine with administrator rights or as a user with program installation privileges.
2. From the Windows **Start** menu, select **Control Panel**, or choose Settings and then **Control Panel**.
3. Select **Uninstall a program**.
4. In the list of currently installed programs, select **PinCH 3.2**.
5. Select the **Uninstall** button.

Chapter 3

PinCH Guided Tour

3.1 PinCH Processing Steps

In order to begin the guided tour of the PinCH software several important aspects of a pinch analysis study should be reviewed. The application of the pinch method is manual in nature; however, it provides a systematic and structured approach to the difficult problem of overall system design [1]. The method places a considerable amount of responsibility on the user to fully understand the process they are focused on optimizing. This in itself provides a strong benefit as design engineers will develop a greater knowledge of the process that they are optimizing.

Fig. 3.1 shows the project flow diagram for a typical pinch study in industry [2]. The flow involves 3 major phases 1) mass and energy balance validation, 2) pinch method calculations and 3) new design change recommendations. The PinCH software mainly focuses on supporting the second phase involving targeting and heat exchanger network design calculations. The skills involved in the first and third steps can only be minimally supported and require the design engineer to develop the necessary skills in process engineering and unit operation design through learning and experience.

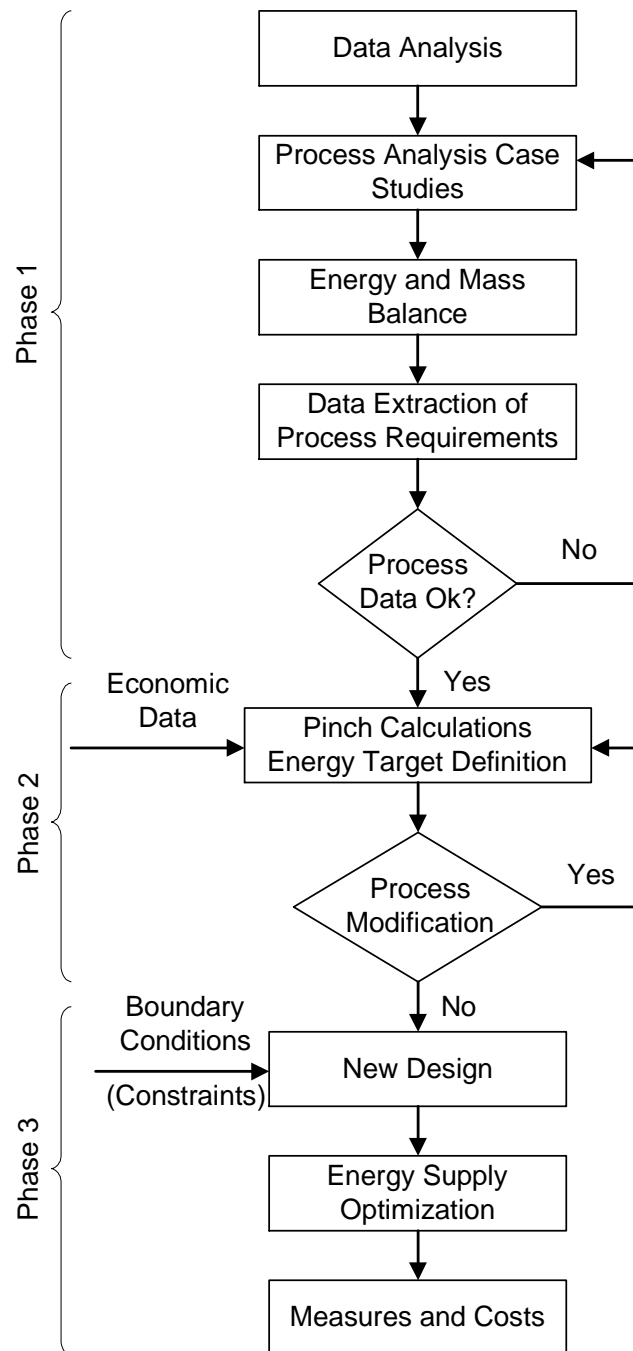

Fig. 3.1: Pinch analysis study process

However, within the context of the pinch study calculations, ten major processing steps were identified that are typically done and are directly supported in the PinCH software. They are as follows:

1. Enter Stream Data
2. Configure Equipment
3. Define Processes
4. Apply Scheduling to Processes
5. Set Economic Data
6. Prepare Targeting Calculations
7. Analyze Energy Targets
8. Calculate Energy and Cost Targets
9. Integrate Energy Conversion Units
10. Design Heat Exchanger Networks

Note: On the PinCH menu click on **Help > PinCH Process Guide** to view a dynamic diagram of the 10 steps. The first step is clearly focussed on supporting phase 1 of the pinch study process in order to allow easy inputting of stream data and process requirements. However, steps 2, 3, 4 and 5 are unique in that they allow the complete definition of the process(es) from a static perspective. This definition allows the flexibility to manage different scenarios and variability studies involved in the pinch analysis calculations.

Steps 6, 7, 8 and 9 allow the configuration of result scenarios used in performing heat integration Targeting calculations. Finally, step 10 encapsulates the detailed design requirement for the HEN exchanger network based on the targeting results. The transition from 1 - 10 supports one of the golden rules of pinch analysis, which is:

Targets Before Design

The structured set of steps and the support given in the PinCH software eases the challenge of analyzing the many different scenarios possible. Each of these options requires repeating the targeting and then constructing new HEN designs. PinCH manages each of these steps through the use of graphical user interface object visualizers. The key features include the ability to

create complex plant design scenarios for the analysis of single continuous, multiple base case and single product batch processes. Once standard targeting calculations are complete, detailed heat exchanger network grid diagrams can be created to produce minimum energy or relaxed designs. Some of these features will be introduced next.

3.2 Major Graphical Components of PinCH

When you open PinCH the application Workbench will be displayed. Fig. 3.2 shows a calculated result. In order to view these major graphical components shown please open a project case as follows:

1. Select **File > Open Project** on the main menu (see Fig. 3.2 point 1).
2. In the Open Project dialog navigate to **(install directory) > PinCH > Tutorials** and select the project **FourStreamEx2.PinCH**.
3. Select to expand the **New Target Group** node shown in the Target Explorer.
4. Select the **Results tree node** and right click to bring up the context menu and select **Calculate Target Result with... > Separate Design Tool**.
5. Select the check box under **Costs** in the OC Charts header bar of the resulting Target Result visualizer.

The PinCH workbench should now show the target result calculated for the given process.



Fig. 3.2: PinCH Workbench and the major graphical components

Referring to Fig. 3.2 the major components included are the following:

1. Main menu bar.
2. Project Explorer - used to define static information related to processes and their scheduling as well as global economic data.
3. Target Explorer - used to configure and manage the generation of results that are based on the information supplied in the project explorer.
4. Process Stream Table - data grid used to hold all stream related information derived from the data extraction process and used in calculating the targets and building HEN designs.
5. Utility Stream Table - data grid to hold all utility stream related information used in designing and optimizing the utility systems for a given target result.

6. Target Result Visualizer - used to encapsulate all results related to a particular targeting calculation. Results include the following for *direct heat recovery* analysis for heat exchanger networks:
 - a. Overall Gantt chart.
 - b. Batch Gantt chart or Weekly Operating Case (OC) Gantt chart.
 - c. Composite curves.
 - d. Grand composite curve.
 - e. Balanced composite curve.
 - f. Balanced grand composite curve.
 - g. Cost curves.
 - h. Carnot factor curve
 - i. Split grand composite curve.
 - j. OC or Time Slice (TS) data grid to view targeting results. Here you can set the targets for a specific ΔT_{min} and size utilities.
 - k. OC or TS Selector.
 - l. Perspectives combo-box selector to change the layout of the charts, and grids based on the simple workflow of Orientation, Optimizing and Analyzing.

For *indirect heat recovery* results the following is included:

- a. Indirect Source Sink Profile (ISSP).
- b. Required Number of Intermediate Loop/Heat Storages vs. Heat Recovery chart.
- c. Payback vs. Heat Recovery chart.
- d. Loading/Unloading Thermocline profile.
- e. Capacity Limitation Analysis chart.
- f. Sources and Sinks Data grid.
- g. Intermediate Loop/Heat Storage Energy and Cost savings data grids.
- h. Heat Exchanger and Storage Network schema.

An additional base graphical component is the HEN grid as shown in Fig. 3.3.

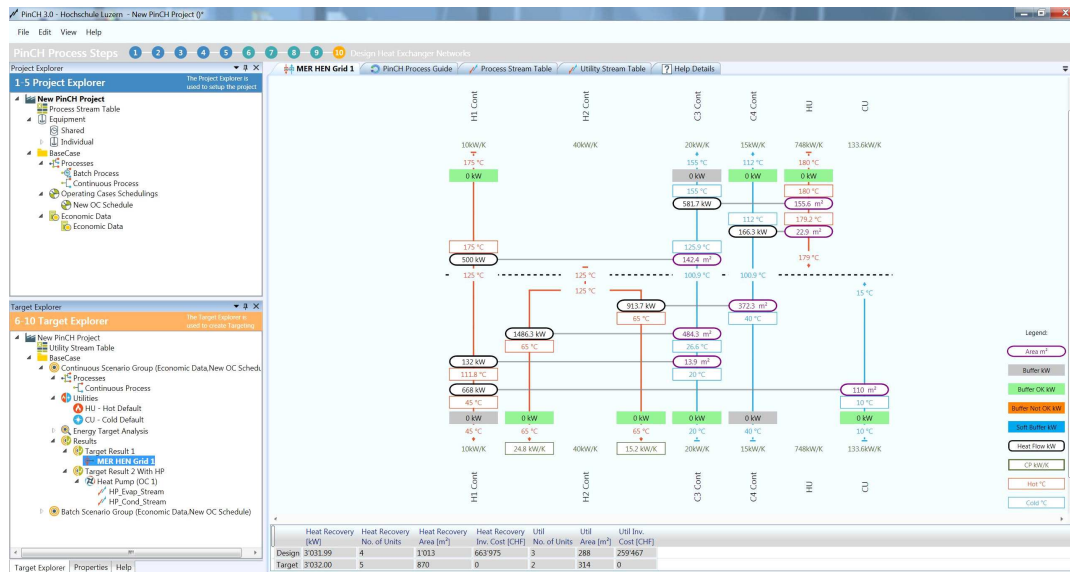

Fig. 3.3: PinCH Workbench showing a HEN Grid

In order to create and view the HEN please do the following:

1. Start the PinCH software.
2. Click with the left mouse button on the number **1** shown by the **PinCH Process Steps** (shown immediately below the menu items at the top of the desktop). This will load a previously prepared demo file.
3. Open the tree view of the Continuous Scenario Group.
4. Right click on the MER HEN Grid 1 and select **Show HEN**.

The HEN grid for the particular minimum temperature difference will be displayed. This heat exchanger network design was created by placing heat exchange matches between the displayed streams to meet the minimum energy requirements defined by the three golden pinch rules. The details of each of the components are presented in subsequent sections. In addition, the reader is encouraged to read and learn about the principles of the pinch method in the several references listed at the end of this document

3.3 Process Types Modeling

Industrial processes are typically distributed and dynamic in nature. As a result, a real world industrial plant often involves several production processes,

possibly operated independently of each other, in one or several buildings or areas. They can be characterized into continuous as well as batch operation with various other scheduling opportunities spread between. In addition, even in cases when only one process is operated, it may feature some changes in the operating conditions over the year. This could be either due to, for example, changes in climate conditions or changes in the feed being processed and the corresponding adjustments in the production recipes (e.g. flakes made from corn or from wheat, different colour of paint, etc.).

PinCH has been designed to allow such real world problem specificities to be taken into account, and modelled in a basic time scheduled manner. It provides the user with flexible tools to define these specifications, to decide which processes must be heat integrated together, and how to integrate them.

The following base process scheduling types are supported in PinCH:

3.3.1 Single Process Continuous

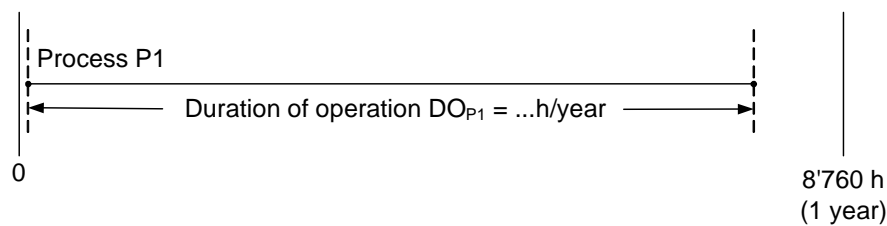

Fig. 3.4: Diagram illustrating a single continuous process

This is the simplest process type commonly found in industry: constant process conditions of process P1 over the whole duration of operation of the process DO_{P1} .

Note that since there is only one process the schedule has no influence other than duration.

3.3.2 Multiple Processes, Continuous And Synchronous

This case includes two or more synchronous processes, e.g. linked continuous processes contributing to the production of one or more products. A priori, the processes are not grouped in a single overall process because typically they are not close enough to each other in actuality to allow direct heat integration between the streams of the different processes. As for the case

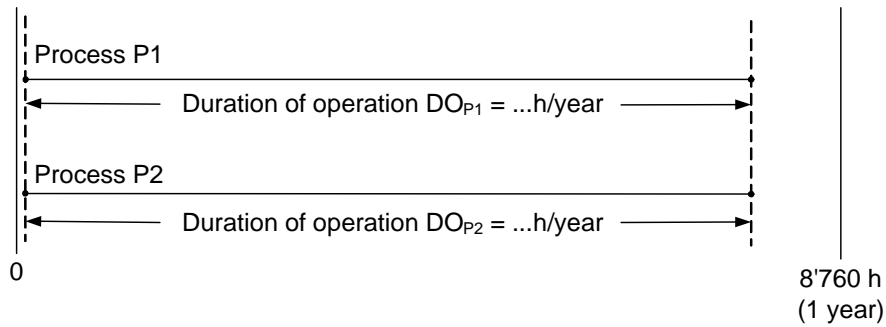

Fig. 3.5: Diagram illustrating multiple processes, continuous and synchronous

described for single continuous, the processes start at an arbitrary time point of 0 and the schedule has no influence on the result as long as the processes are synchronous.

3.3.3 Multiple Processes, Continuous, Not Overlapped

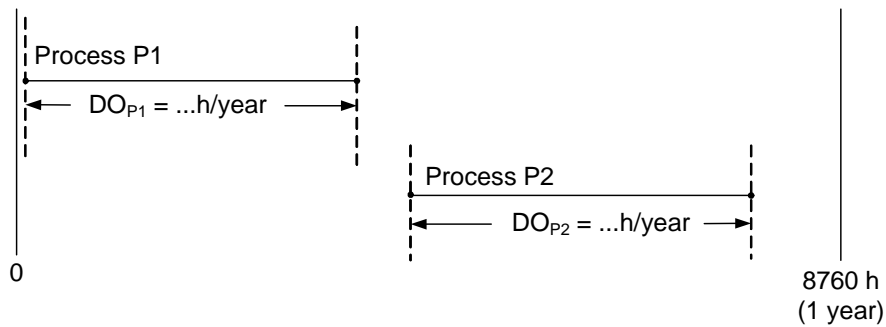

Fig. 3.6: Diagram illustrating multiple processes, continuous, not overlapped

This case includes two or more continuous processes, not overlapped. The time difference between the end of P1 and the beginning of P2 may be variable. Therefore, it is assumed that heat integration between P1 and P2 is either not feasible, or uneconomic. As a consequence, the heat integration of P1 and P2 may be analysed independently of each other.

However, the above reasoning does not hold anymore, if P1 and P2 are processes organised on a weekly basis (often found in food industry), i.e. P1 operated at the beginning of each week, while P2 would follow during the second part of the week. In this case:

- heat integration through intermediate heat storage may be possible if the process pinch of P1 is significantly different from that of P2, and potentially profitable

- the base period considered to define the schedule should not be one year, but one week (to correctly account for the number of heat storage cycles; an important issue for the profitability), and the user should then define the number of weeks per year this schedule is repeated

As with the case described previously, this process may also start at 0. The schedule has no influence on the results as long as the processes are not overlapped.

Note: If the processes have different periods but are the same processes then the opportunity to design a heat exchanger network valid for all the operating cases must be done.

3.3.4 Multiple Processes, Continuous, Overlapped

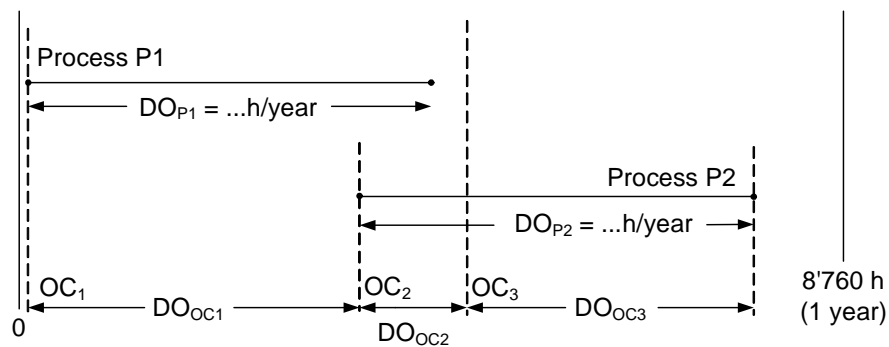

Fig. 3.7: Diagram illustrating multiple processes, continuous, overlapped

This case includes two or more continuous processes that partially overlap, which defines the operating cases (here OC_1 , OC_2 , and OC_3 , of duration DO_{OC1} , DO_{OC2} , and DO_{OC3} , respectively). OC_2 introduces (as far as the heat integration between P1 and P2 is feasible and profitable) a link for optimization possibilities based on the heat integration of both processes. The significance of this link depends, among other things, on the duration of DO_{OC2} and the associated improvement of the heat recovery target compared to that involving only the heat integration of P1 and P2 separately.

3.3.5 Single Process, Multiple Operating Cases

This process type scheduling can consist of several continuous processes following closely after each other sequentially. These types of Multiple Operating cases (MOC) can occur due to season changes that affect operation

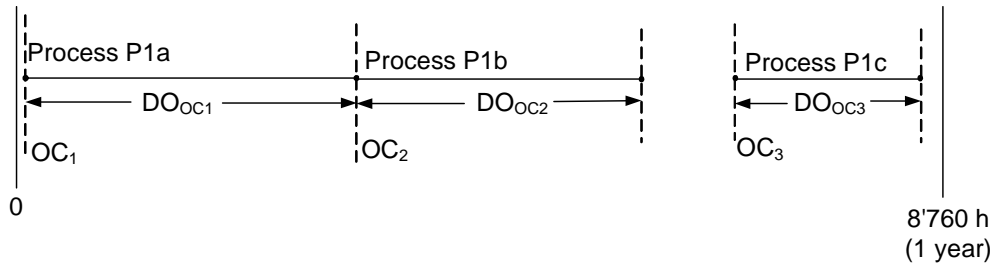

Fig. 3.8: Diagram illustrating a single continuous process with multiple operating cases

even though the process is the same product. It is assumed that heat integration between P1a, P1b and P1c is either not feasible, or uneconomic. As a consequence, the heat integration of P1a, P1b and P1c may be analysed independently of each other. However, the design goal is to find a single overall heat exchanger network design flexible enough to handle the changing heating and cooling requirements between P1a, P1b and P1c. Investment cost must be kept low by reusing common heat exchangers in each of the operating cases created by P1a, P1b and P1c. Combined supertargeting techniques are used to find the required area and cost for such multiple operating cases (MOC).

However, the above reasoning does not hold if P1a, P1b and P1c are processes organised on a weekly basis (often found in food industry), i.e. P1a operates at the beginning of each week, P1b operates during the middle of each week and P1c operates at the end of each week. In this case:

- heat integration through intermediate heat storage may be possible if the process pinch of P1a is significantly different from that of P1b and P1c, and is also potentially profitable
- the base period considered to define the schedule should not be one year, but one week (to correctly take the number of heat storage cycles into account – an important issue for the profitability), and the user should then define the number of weeks per year this schedule is repeated

Note: Indirect heat integration capabilities based on heat storage are available in PinCH by simply modelling semi-continuous streams (e.g. chiller waste heat on a daily basis) as batch streams (see section 3.3.6).

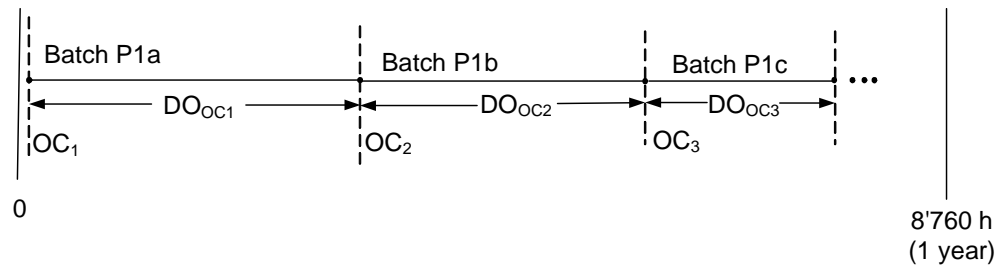

Fig. 3.9: Diagram illustrating a sequential batch process

3.3.6 Single Process, Batch

This type of process consists of several batch processes following sequentially after each other. Direct heat integration between the batches P1a, P1b and P1c is not feasible. However, indirect heat integration would be a possible means to exchange energy between the time slices of each batch. In this case:

- heat integration through intermediate heat storage may be possible if the process pinch of P1a is significantly different from that of P1b and P1c, and is also potentially profitable
- the base period considered to define the schedule should not be one year, but one week (to correctly take the number of heat storage cycles into account – an important issue for the profitability), and the user should then define the number of weeks per year this schedule is repeated

Note: Indirect heat integration capabilities are fully supported in the PinCH software using heat storage of batch and semi-continuous streams as covered in later chapters.

Chapter 4

Using the Process Stream Table

4.1 Importance of Proper Data Extraction

Data extraction is a very important activity in the overall pinch analysis project process. This project phase (see Fig. 3.1) involves a large effort to analyze an industrial process and derive the necessary stream information needed for a pinch analysis. In this first phase, the engineer is responsible for analyzing the entire boundary of operation of a given industrial process and to breakdown the structure into appropriate time and space dimensions. The assumptions made in organizing the structure is important to ensure an adequate level of modelling complexity is maintained, yet being certain to not exceed the necessary amount of details for an adequate analysis (i.e. attain a manageable level but still incorporate the key features for heat integration studies). As a result, the engineer will typically have to first identify the type of processes present, their location on the site relative to each other, any limits corresponding to the interfacing of these distinct processes, the range of products (recipes) and their different production lines (conditions and schedule) and finally include any special side processes (e.g. HVAC). Each of these process characteristics will generate different target results. More generally, it is often observed in practice that these characteristics influence the manner in which the process streams (or process requirements) are identified for use in the pinch analysis, depending on what can be assumed to be modifiable and what can not. This process stream analysis is a very challenging aspect of a pinch analysis, yet it provides immediate benefits even before the pinch calculations are performed.

Given the importance of data extraction, the PinCH program provides a convenient data grid component to allow the easy entering or importing of

stream data and other features to aid the engineer in ensuring the data is complete and of high quality. The next sections provide details related to using the functionality available in the Process and Utility Stream Tables where the core process requirements are entered.

4.2 The Stream Table (Process Requirements)

The Process Stream Table contains the process requirements (stream data) established during the data extraction phase. In pinch analysis, these requirements are represented through the common definition of **Hot Streams to be cooled down and Cold Streams to be heated up** in a system.

It is assumed the physical properties of a stream remain relatively constant in most circumstances. However, this is not always true (e.g. crude oil or humid air) and a stream can be divided into one or more segments in order to provide improved accuracy in calculating the pinch analysis target values.

Each stream and its associated segments are stored along with the specific parameters such as temperature, pressure, mass flow, etc. in the project file. These values are read upon opening the project file and displayed as shown in Fig. 4.1.

This chapter focuses on using the Process Stream and Utility Stream tables within PinCH and the various functions available to the user when entering stream data.

+/-	Name	Hot/Cold	Tin [°C]	Tout [°C]	m [kg/s]	Cp [kJ/(kg*K)]	Phase Change [kJ/kg]	α [W/(m ² *K)]	Pressure [bar(a)]	CP [kW/K]	ΔH [kW]	Fluid	Humidity Ratio In [kg/kg]	Soft	tstart [h]	tstop [h]
	H1	✓	120	40	2	3	-	1000	-	6	480	Simple	-	<input type="checkbox"/>	1.17	3.67
	H2	✓	105	75	5.33333	3	-	1000	-	16	480	Simple	-	<input type="checkbox"/>	0	1.17
	C1	✓	50	115	2.33333	3	-	1000	-	7	455	Simple	-	<input type="checkbox"/>	0	1.17
	C2	✓	65	80	20	3	-	1000	-	60	900	Simple	-	<input type="checkbox"/>	1.17	2.17
	C3	✓	70	120	2.334	48.429	-	-	1	113.03	5651.67	Water	-	<input type="checkbox"/>	2.17	3.67
	1	✓	70	99.63	2.334	4.1606	-	1000	1	9.71	287.69	Water	-	<input type="checkbox"/>	2.17	3.67
	2	✓	99.63	99.63	2.334	-	2257.08	1000	1	-	5268.02	Water	-	<input type="checkbox"/>	2.17	3.67
	3	✓	99.63	120	2.334	2.0179	-	1000	1	4.71	95.96	Water	-	<input type="checkbox"/>	2.17	3.67
	H1 Cont	✓	175	45	1	10	-	200	-	10	1300	Simple	-	<input type="checkbox"/>	-	-
	H2 Cont	✓	125	65	1	40	-	200	-	40	2400	Simple	-	<input type="checkbox"/>	-	-
	C3 Cont	✓	20	155	1	20	-	200	-	20	2700	Simple	-	<input type="checkbox"/>	-	-
	C4 Cont	✓	40	112	1	15	-	200	-	15	1080	Simple	-	<input type="checkbox"/>	-	-

+/-	Name	Hot/Cold	Tin [°C]	Tout [°C]	m [kg/s]	Cp [kJ/(kg*K)]	Phase Change [kJ/kg]	α [W/(m ² *K)]	Pressure [bar(a)]	CP [kW/K]	ΔH [kW]	Fluid	Humidity Ratio In [kg/kg]	Soft	tstart [h]	tstop [h]
	H1 Cont	✓	175	45	1	10	-	200	-	10	1300	Simple	-	<input type="checkbox"/>	-	-
	H2 Cont	✓	125	65	1	40	-	200	-	40	2400	Simple	-	<input type="checkbox"/>	-	-
	C3 Cont	✓	20	155	1	20	-	200	-	20	2700	Simple	-	<input type="checkbox"/>	-	-
	C4 Cont	✓	40	112	1	15	-	200	-	15	1080	Simple	-	<input type="checkbox"/>	-	-

Fig. 4.1: Process Stream Table to allow entry of the heating and cooling requirements determined during data gathering and extraction

As shown in Fig. 4.1 the major components included are the following:

1. Main Process Stream Table - A complete listing of streams and segments.
2. Stream Row - A summary of the major parameters associated with the bulk stream properties.
3. Segment Row - The specific parameters associated with the section of the stream where either a major change in C_p or a change in phase occurs.
4. Process Stream Table Context Sensitive Menu - The menu listing can be shown by right clicking on a row in the Process Stream Table. This context menu is the key entry point to execute commands against the stream table. The commands are as follows:
 - a. Add Continuous Process Stream
 - b. Add Batch Process Stream
 - c. Add Process Stream Segment
 - d. Copy Process Stream
 - e. Remove Process Stream
 - f. Remove Process Stream Segment
 - g. Properties
5. Working Stream Table - This table displays the streams assigned to a particular process grouping (please see section 6).

In addition to the Process Stream Table, there is also the Utility Stream Table. This table is similar to the Process Stream table, but contains only the necessary information to calculate the required mass flowrate of a utility for a given heat flow. Since each Target Result (see sections 7, 8 and 9) calculates the required hot and cold duty requirements, only the physical properties necessary to define the utility are needed. It should be noted a stream is considered a utility if it supplies or removes energy over a system boundary, **but itself can be replaced easily with another utility stream**. In this case it is not to be considered as part of the process and should be placed into the Utility Stream Table.

In both the Process Stream Table and Utility Stream Table, the streams can be shifted upwards or downwards in the data grid. This can be done by pressing Alt + up/down Arrows to reposition the streams accordingly.

4.3 Defining Streams

The definition of streams and their associated segments consist primarily of two main types: Simple and Fluid. The most basic yet most important is a Simple stream, which can be defined in a flexible and direct manner based on either the streams heat capacity flowrate (CP) or the heat of vaporization/condensation (phase change). Fluid streams are based on internally calculated physical property calculations for water, common refrigerants (e.g. R134a) and humid air. By simply choosing the required fluid under the Fluid column (Fig. 4.1), PinCH will automatically calculate the necessary physical property data and segment the stream according to the phases present [3 - 4]. The base stream parameters are defined in the following tables for both the Process and Utility Stream Tables:

Tab. 4.1: Process Stream Table Properties

Process Stream Parameters	Description	Units
Name	Stream or segment name	
Hot / Cold	Designation if stream or segment is hot or cold	
T_{in}	Stream or segment starting temperature	°C
T_{out}	Stream or segment end temperature	°C
\dot{m}	Stream or segment mass flow rate	kg/s
C_p	Segment specific heat capacity	kJ/kg K
Phase Change	Segment heat of vaporization, condensation or fusion (simple streams only)	kJ/kg
α	Segment heat transfer coefficient	W/K m ²
p	Absolute stream pressure	bar
CP	Heat capacity flow rate	kW/K
$\Delta\dot{H}$	Heat flow of a stream or segment	kW
Fluid	A selection list to choose between simple, water, refrigerant or humid air stream types	
Humidity Ratio In	The water content of an air stream at its inlet conditions	kg H ₂ O / kg dry Air
Soft	Designation if a stream or segment can be included optionally into the targeting calculation	
t_{Start}	Stream existence start time (absolute)	hour
t_{Stop}	Stream existence end time (absolute)	hour

Tab. 4.2: Utility Stream Table Properties

Utility Stream parameters	Description	Units
Name	Stream or segment name	
Hot / Cold	Designation if stream is hot or cold	
T_{in}	The starting temperature of a stream	°C
T_{out}	The ending temperature of a stream	°C
C_p	Stream or segment specific heat capacity	kJ/kg K
Phase Change	Heat of vaporization or condensation (simple streams only)	kJ/kg
α	Heat transfer coefficient	W/K m ²
p	Absolute stream pressure	bar
Utility Cost	Specific cost of the utility stream	CHF/kWh
Fluid	A selection list to choose between simple, water, refrigerant or humid air stream types	
Humidity Ratio In	The water content of an air stream at its inlet conditions	kg H ₂ O / kg dry Air

Specifying Streams (Degrees of Freedom):

In order to fully specify a stream to allow calculation of the heat flow necessary in the pinch analysis calculations, not all information must be set. The Stream Tables **automatically check the degrees of freedom** to see if enough information is already available to calculate the remaining energy related variables (\dot{m} , c_p , CP , $\Delta\dot{H}$). Each stream or segment row is entirely flexible in the combinations that can be supplied. However, the most common is to provide the \dot{m} and the C_p (for sensible heat streams or segments). However, the heat flow or the CP values can also be directly given.

The \dot{m} and phase change are most commonly entered for streams or segments that experience a phase change such as condensation or evaporation. However, the heat flow can be directly entered if known.

Note: An isothermal phase change can be set to be either a hot (i.e. **condensing**) or cold (i.e. **evaporating**) stream **by simply clicking on the stream Hot/Cold arrow** to manually set the type of phase change. Default is a cold stream when first setting $T_{in} = T_{out}$.

Specifying Streams (Bubble and Dew Point):

Fluid streams calculated based on the steam tables (e.g. water) or based on the equation of state in [4] (e.g. R134a, etc.) can be specified to be exactly at their boiling or dew points. This specification can be for either the stream inlet or outlet state and is done by using the common thermodynamic notation for quality (x0 for boiling point and x1 for dew point). To force the calculation of the bubble or dew point condition, simply enter either of these values for T_{in} or T_{out} . PinCH automatically determines the exact bubble point temperature or dew point temperature based on the underlying fluid thermodynamic model as well as the $\Delta\dot{H}$ based on the given \dot{m} .

Note: The quality can be specified over the range from x0 to x1 to allow partially condensed states to be modelled. Also the isothermal phase change can be set to be either a hot (i.e. **condensing**) or cold (i.e. **evaporating**) stream **by simply clicking on the stream Hot/Cold arrow** to manually set the type of phase change.

4.4 Configuring Fluid Types

The Fluid column shown in the Stream Tables allows the user to select a specific component in order to automatically calculate the representative streams and segments. The following table 4.3 lists the components that are available.

Tab. 4.3: Fluid Types

Fluid Type	Name	Calculation Basis
Water	H ₂ O	Stream properties calculated using the Steam Tables
Humid Air		Stream properties calculated for an air stream that undergoes partial condensation
R134a	1.1.1.2-tetrafluoroethane	Properties calculated using the Lee and Kesler [4] equation of state
R404A	R125 / 143a 134a (44/52/4)	Properties calculated using the Lee and Kesler [4] equation of state using pseudo mixture properties

Continuation of table:

Fluid Type	Name	Calculation Basis
R245ca	1.1.2.2.3-pentafluoropropane	Properties calculated using the Lee and Kesler [4] equation of state
R245fa	1.1.1.3.3-tpentafluoropropane	Properties calculated using the Lee and Kesler [4] equation of state
R407C	R32 / 125 134a (23/25/52)	Properties calculated using the Lee and Kesler [4] equation of state using pseudo mixture properties
R410A	R32 / 125 (50/50)	Properties calculated using the Lee and Kesler [4] equation of state using pseudo mixture properties
R600	N-Butane	Properties calculated using the Lee and Kesler [4] equation of state
R600a	Iso-Butane	Properties calculated using the Lee and Kesler [4] equation of state
R601	N-Pentane	Properties calculated using the Lee and Kesler [4] equation of state
R717	NH ₃ Ammonia	Properties calculated using the Lee and Kesler [4] equation of state
R718 Water	H ₂ O	Properties calculated using the Lee and Kesler [4] equation of state
R723	NH ₃ Dimethyl-ether (60/40)	Properties calculated using the Lee and Kesler [4] equation of state using pseudo mixture properties
R744	CO ₂	Properties calculated using the Lee and Kesler [4] equation of state
Ethanol	C ₂ H ₆ O	Properties calculated using CoolProp Fluid Property [18], ORC ECU Only
MDM	Octamethyltrisiloxane	Properties calculated using CoolProp Fluid Property [18], ORC ECU Only
Toluene	C ₇ H ₈	Properties calculated using CoolProp Fluid Property [18], ORC ECU Only

The calculation of the water and refrigerant components are handled internally using the listed calculation procedures.

The humid air partial condensation process is modeled by assuming ideal conditions. In a first step, the gas is assumed to be cooled completely to the dew point. A second step divides the remaining temperature range into equal

segments and calculates the average C_p in each interval for the combined air and condensate mixture. The segmented stream can be calculated simply by selecting humid air and setting appropriate pressure and temperature levels.

Note: The mass flow rate of the humid air fluid is calculated and displayed on a **dry basis** as is the norm in engineering calculations.

4.5 Configuring Utility Streams

In PinCH, process streams and utility streams are considered separately. A utility is defined as a stream that is used to provide the necessary energy requirements for heating and cooling the process being analyzed. Most significantly these are streams that are not necessary for the process to produce the product. A corollary to this statement is that a utility stream is one that can be replaced by any other utility stream as it is not part of the process.

A typical site utility is steam that can be used to exchange energy in a heat exchanger with other process streams. However, steam could be injected directly into a distillation column to replace the function of a reboiler in addition to providing additional stripping effects. In this case, the steam is more commonly considered as a process stream and not a utility.

Definition of utility streams is done on a separate window from the standard process streams. These streams are characterized by the fact that no mass flow nor heat flow can be entered (as it is in the Process Stream Table). The reason is that utility streams belong to a particular target result (see section 7) and the corresponding composite curve. Their heat flow is calculated directly based on the selected ΔT_{min} of the composite curves resulting in the direct determination of the required mass flow for the given heat capacity or phase change value. These calculations are handled internally and the user only needs to supply the state properties of the utilities they require (see Fig. 4.2)

+/-	Name	Hot/Cold	Tin [°C]	Tout [°C]	Cp [kJ/(kg*K)]	Phase Change [kJ/kg]	α [W/(m ² *K)]	Pressure [bar(a)]	Utility Cost CHF/kWh	Fluid	Humidity Ratio In [kg/kg]
	HU		180	179	30000	-	200	-	0.03	Simple	-
	CU		10	15	3	-	200	-	0.005	Simple	-

Fig. 4.2: Utility Stream Table showing multiple utilities (note: the mass flow and heat flow do not need to be given as they are determined by the targeting result directly)

4.6 Configuring Soft Streams

The concept of a soft stream relates to the fact that some process streams often are left on their own to equilibrate with the conditions of the environment. Examples include streams that are sent directly to tanks to cool or exhaust air vented to atmosphere. However, it may be beneficial to use a portion of such streams for additional energy recovery. Therefore, it is of value to assess in a process integration study if it is worthwhile to use a portion of this energy. As a result, the Soft parameter is included with process streams to allow the ability to easily check for energy integration possibilities with such soft parts of streams.

Within the target result (see section 7) the part of the stream that is considered hard or soft is taken into consideration in the targeting calculation where the soft part of the stream is excluded. On the process Stream Table the selection of the parameter soft only indicates the stream can potentially be used as a soft stream. The designation of how much of the stream is soft is done in the target result window (see section 7).

4.7 Importing and Exporting

The importance of being able to import from such spread sheeting software such as Excel is important for many engineers and technical employees as they often use such software for storing and calculating process related information. As a result, the Process Stream Table can be imported from a simple csv formatted file to allow easy insertion into the PinCH Process Stream Table regardless of the source. Given the prevalence of Excel in the marketplace the following example illustrates how to export and then import to Excel.

Exporting from the Process Stream Table:

1. Select **File > Open Project** and then open the FourStreamEx1.PinCH located in the Tutorials directory.

2. Select the **Process Stream Table** tab.
3. Select **File > Export Stream Table To...** dialog.
4. Name and store the Comma Separated Values (csv) format file on to your desktop.
5. Start Excel and select **File > Open**.
6. In the Open Dialog, change the file type to **All Types**.
7. In the Open Dialog, navigate to the desktop and select the saved csv format file that was exported in step 3.

The Process Stream Table information should now be displayed along with the headers showing the column names and units. Even though the data has been saved in a csv format, the saved format can be easily changed using the File / Save As menu item in Excel.

Note: Fluid streams are exported with only their bulk stream properties. As a result, any custom entered segment specific properties (e.g. α) will not be stored if there is more than one segment.

Importing to the Process Stream Table:

In order to import the Process Stream Table into PinCH from Excel, the same format as seen after exporting will need to be used. Therefore, by simply exporting the data to see the format, the data can be easily set up in Excel and then Imported using the following steps.

1. Select **File > New Project**.
2. Select **File > Import Stream Table** to show the **Please choose a Stream Table to Import** dialog.
3. Ensure the csv file that you wish to import is **not open in another program** before proceeding.
4. Navigate to the desktop and select the saved csv that was exported previously.

The data stored in the csv will be automatically loaded into the Process Stream Table and ready to be used in completing the pinch analysis calculations.

Note: Importing of stream data from a csv file will be appended to the end of existing streams already entered into the stream table.

To best understand how the fixed header structure needs to be configured, it is recommend to simply complete a test export beforehand. By simply setting up stream examples in PinCH first and exporting them, you will be able to see the necessary header as well stream/segment structure that is needed. Afterward, you will be able to manually configure streams in Excel and import them successfully into the software.

Note: In addition to the stream table data, any assigned processes that the stream belong to can be exported or imported. In addition, the stream specific equipment data (equipment name, pre and post processing times) are also included in the export and import data.

Chapter 5

E-Modules (Energy Modules)

5.1 Introduction

E-Modules (EMs) were developed in order to facilitate the task of heat integration in energy intensive industrial processes. EMs are Excel based models of particular processes or unit operations, such as combustion, evaporation or drying processes. The aim of the modules is to guide the engineer through the energy analysis and provide an idea of which parameters are required for energy integration. Once the parameters are known they are compiled into a stream table within the EM ready to be used in the pinch analysis; this stream table can then be imported into the PinCH software.

EMs are sophisticated tools that can be used for process modeling and process integration, yet they have been constructed in a manner that is both easy to use and understand. It should be noted that EMs do not completely simulate a chosen production process, **instead they represent a simplified illustration of the whole technical process in order to help the user generate and transfer the relevant data to the PinCH software.** The predefined EMs available for users of the PinCH software provide a quick and powerful alternative for modeling and understanding processes and their energy demand with reasonable accuracy.

In this chapter PinCH users will learn the following:

- where to obtain EMs,
- what are the defining characteristics of EMs,

- how they can use EMs and
- how to use the PinCH Add-In functions for Excel in order to quickly calculate material properties.

5.1.1 System Requirements

Before starting with EMs it is imperative that the correct programs are installed on your computer. The two programs required to be able to use the modules are:

1. PinCH version 3.2 or higher
2. Microsoft Excel 2016 or higher

Note: This user manual does not provide direct information on how to use Microsoft Excel. Only how to use Excel in relation to PinCH E-Modules.

5.2 Obtaining E-Modules

E-Modules (EM) have already been integrated into all PinCH versions 3.2 and greater. For users of PinCH version 3.0 a free upgrade to version 3.2 (or greater) is available - for instruction on how to upgrade to the latest PinCH version refer to section 2.3. As older versions of EMs are being updated and new EMs are being developed on an ongoing basis, both by the PinCH team and by third parties, it is up to the PinCH user to check what EMs (and versions) are currently available for use. In this section where to obtain the latest versions of the EMs and how to download them will be discussed.

Information related to the latest/newest versions of EMs can be found on the PinCH web site (see <http://pinch-analyse.ch>). However, the EMs are automatically installed alongside PinCH 3.2 in addition to automatic registering of the necessary E-Module Excel addin for fluid properties calculations. Nevertheless, newer or adapted versions of E-Modules can be easily incorporated into the E-Module Explorer as illustrated in Figure 5.1.

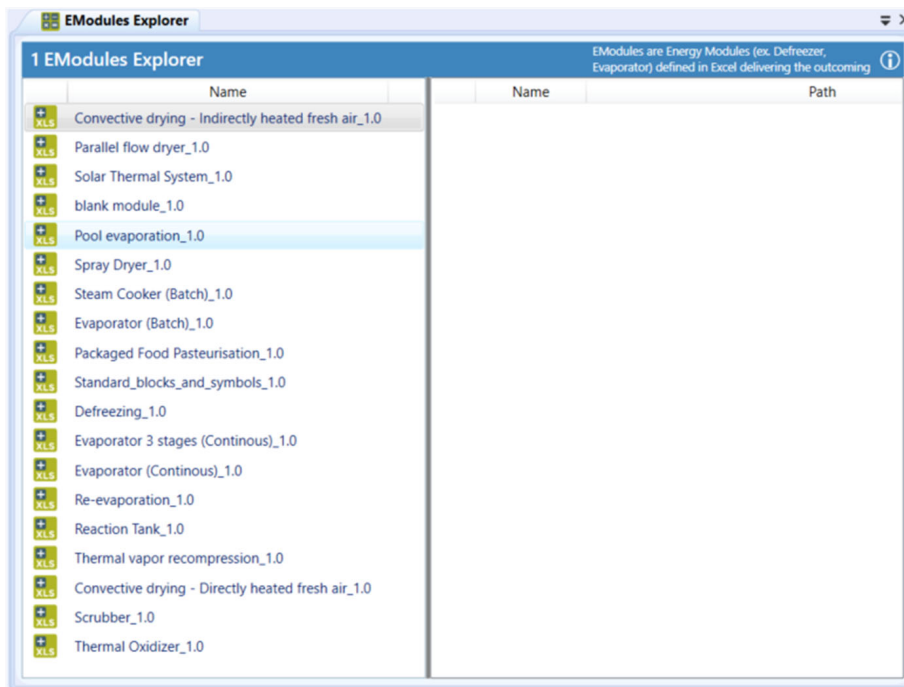

Fig. 5.1: E-Module Explorer

Please do the following to add new or adapted E-modules to the working E-Module folder:

- Open the E-Module Explorer by selecting **View -> E-Modules Explorer**
- Right click on the right-hand side data grid (Working E-Module listing) and select **Open Folder**
- Copy new or modified E-Modules to the folder

Table 5.1 is a short list of EMs currently available in the latest version of PinCH. For the most up-to-date information related to E-Modules please visit the web site.

Tab. 5.1: Different Processes and their E-Modules

Process	Available E-Modules
Combustion	Thermal Oxidizer
Evaporation	Batch Evaporation Continuous Evaporation (single/Multi-stage) Re-Evaporation Pool Evaporation
Cold/Heat Treatment	Defreezing Steam Cooker (Batch) Pasteurization
Reaction	Reaction Tank
Drying	Convection Dryer - Directly Heated, Fresh Air Convection Dryer - Indirectly Heated, Fresh Air Parallel flow dryer Spray Dryer
Cleaning	Scrubber
Solar	Solar Thermal System
Heating	Thermal Vapor recompression

5.3 Getting Started

This section describes the most important, core characteristics of EMs, i.e. those characteristics that are common to all EMs. EMs are designed in a consistent style. This should support the idea of an easy to understand and user friendly application. When frequently using the same blocks and symbols there is for sure an advantage given by the ability of remembering and comparing different processes with each other. The following subsections give a detailed view of the main elements an EM is built of.

5.3.1 Brief Overview

Figure 5.2 shows the basic design of the EM. The following main elements should be available in all EMs to give them a standardised structure:

- The header provides general information about modules. It contains a tracking for changes, a description of the process and explains how calculations should be done. Further, hints for heat integration are given. More information can be found in section 5.3.4.
- The legend explains the colouring and the symbols. (see section 5.3.2.)
- Processes are represented by a black frame and can contain parameters which describe the process. (see section 5.3.5).
- Input and output streams of the process, which are linked through the mass and enthalpy balance over the process (see Appendix A.8.7).
- A stream table which gathers the streams relevant for heat integration. The stream table can be imported directly into PinCH (see section 5.3.6).

Additional information on the different elements of EMs can also be found in Appendix A.8.

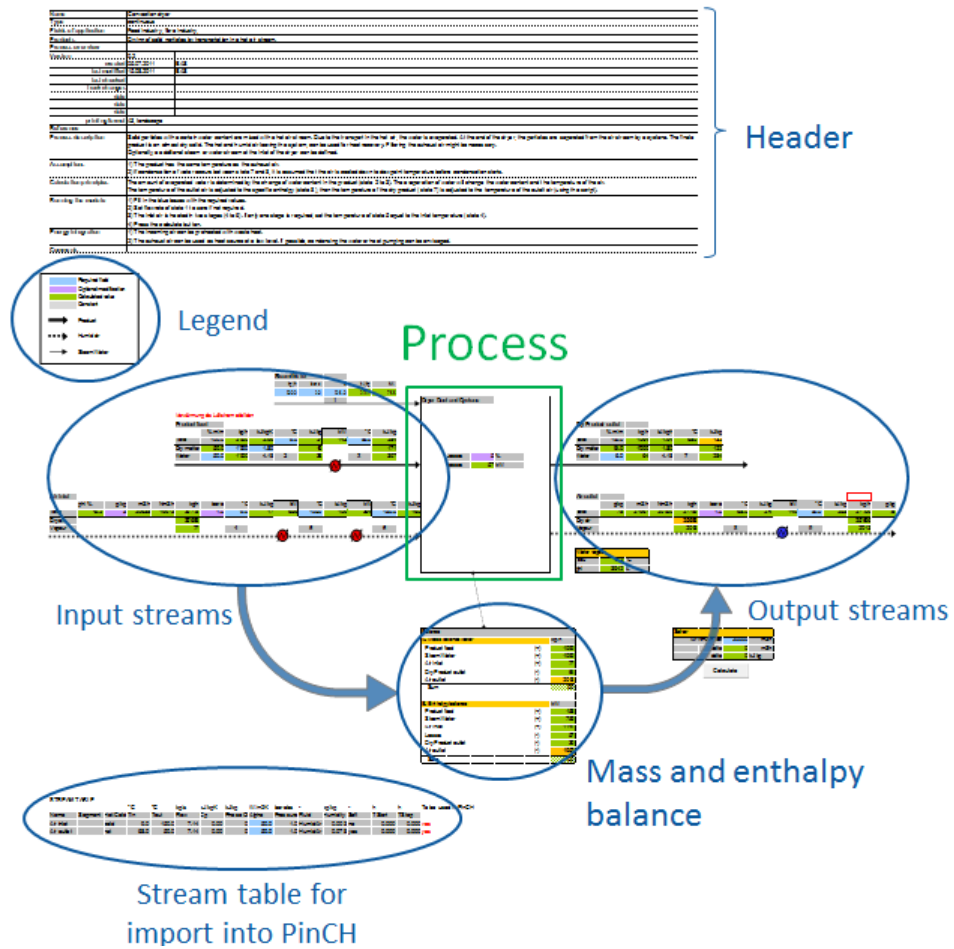















Fig. 5.2: E-Module Overview

5.3.2 Symbols and Coloring

The symbols and colours used in the EM have been standardised, in order to assure comprehensibility for the user when switching from one module to another. Table 5.2 summarizes all the colours and symbols used in the EM.

Tab. 5.2: Symbols and Coloring Used in PinCH E-Modules

	Required Field	These fields are input values which have to be defined by the user. Usually the values can be measured, gathered from the process control system or estimated from the design values. Hint: Sometimes it is possible that a value in a green field is known, but a value in a blue field is missing (for example when other measurements than the proposed measurements are available). In this case, use the solver as described in Appendix A.7
	Optional Modification	Predefined values which can, but do not necessarily have to be modified by the user, if more appropriate values are available. The same colour is used for names of streams, which can be changed by the user if desired.
	Calculated Value	Green fields are automatically calculated values, either used for further calculations or as indication for the user.
	Balance Result/Title	Used to highlight a cell, e.g. a cell that contains a result in the balance box or the title of an information box.
	Constant	Constant values that should not be changed.
	Product	Represents the flow of the product. This can be a solid item, a fluid (other than water or air) or a combination of both. The product is the stream of interest in the process.
	Humid Air	Air with or without a certain content of water vapor
	Steam/Water	Water in liquid or vapor state.
	Heating Only	Heat exchanger that adds heat to the stream
	Cooling Only	Heat exchanger that extracts heat from the stream.

 Heating and Cooling	Heat exchanger where heating and cooling is possible, depending on the definition of the module/process. In batch processes this symbol is usually found when heating and cooling are performed in the same heat exchanger but at a different time
 	The red frame indicates that the cell contains a formula or warning that is not always visible. E.g. the “Condensation” appears when the temperature of the air is below dew point temperature. Cells with red frames should not be overwritten.

5.3.3 Abbreviations

Table 5.3 is a list of the different abbreviations used in the EMs. These abbreviations should also be used when developing your own EMs.

Tab. 5.3: Abbreviations Used in EM

Category 1		Category 2	
% m/m	mass percentage	λ	excess air coefficient
% mol	molar percentage	Comp.	component
% v/v	volume percentage	Cp	isobaric specific heat capacity
bar(a)	pressure in bar absolute	dry	based on dry matter
°C	temperature	HHV	higher heating value
g/kg dry	g per kilogram dry matter (usa. absolute humidity)	LHV	lower heating value
h	hour	Phi	relative humidity
kg/bat	kilogram per batch	ppart	partial pressure
kg/Nm ³	density	Tdew	dew-point pressure
kg/h	mass flow rate	Tsat	saturation temperature (constant pressure)
kJ/kg	specific enthalpy	wet	based on wet matter

Category 1 Continued		Category 2	
kJ/kgK	specific heat	–	–
kg/s	mass flow rate		
kW	(thermal) power		
mol/kg	molar composition (e.g. number of moles/kg fuel)		
m^3	operating cubic meters		
Nm^3	standard cubic meters		
$\text{W/m}^2 \text{ K}$	heat transfer coefficient		

5.3.4 Document Information - Header

The header of each E-Module works as a succinct package insert. Here, all information should be documented in order to clarify possible upcoming questions of future users. The input mask is designed as seen below.

Tab. 5.4: E-Module Header

Name	Short and clear name, used to identify the module in the database. Avoid long phrases or descriptions	
Type	Type of the module: continuous or batch.	
Fields of application	Possible industries in which the module could be useful. The idea is to expand this library continuously	
Products	Products that result in the process which the module covers	
Process overview	Short description of the process. The process overview is the description that is used in database.	
Version	Version number of the module. The same number should be mentioned in the file name.	
printing format	Paper size and orientation	
Reference	All external formulas must be quoted here with a source, so that the calculations are transparent to the user.	
Process description	Detailed description of what happens in the equipment and how. If batch operated, describe the different process stages	
Assumptions	Major assumption made due to simplifying the process for the E-Module are given here.	
Calculation principles	Gives idea of how the different elements in a module are calculated (important calculation principles explained here).	
Running the module	Guides the user through the module and explains the order the input values should be entered, how to use implemented macros and which values must be modified when using the solver.	
Energy integration	Hints and common techniques for energy integration in the specific process.	
Comments	Any additional comments from the developer.	

5.3.5 Standard Blocks and Symbols

The process being modeled in the EM is depicted using the standard blocks. A standard block is defined as a set of input parameters and calculated values, usually describing the cooling or heating of a stream. Combined with the properties library, the standard blocks allow to calculate a wide range of thermodynamic applications in a short time. Figure 5.3 displays a standard block as seen in the EM for an evaporation process.

Product inlet									
	% m/m	kg/h	kJ/kgK	°C	kJ/kg	kW	°C	kJ/kg	
Total	100.0	7714	3.55	50.0	178	190	75.0	267	
Dry prod.	21.0	1620	1.20		60			90	
Water	79.0	6094	4.18	1	209		2	314	



Fig. 5.3: Standard Block for Evaporation Process

Typical parameters which are contained in the standard blocks are (in brackets: units as used in the EM):

- mass flow [kg/h]
- temperature [°C]
- pressure [bar (a)]
- enthalpy [kJ/kg]
- electrical or thermal power [kW]
- water content [g/kg]

How to work with standard blocks will be discussed in section 5.4. To learn how to build your own standard blocks refer to Appendix A.8.

5.3.6 Stream Table

A stream table is defined in every module. It contains all hot and cold streams of the process. The data is represented such that the stream table can be imported directly into the PinCH software. The majority of the data is automatically copied from the process into the stream table. Figure 5.4 is an example of the stream table from the Defreezing E-Module, however, the headings for the stream tables in all the EMs are the same - only the number of streams and the stream names change. Table 5.5 describes the different headings found in the stream tables.

STREAM TABLE

Name	Segment	Hot/Cold	°C Tin	°C Tout	kg/s Flow	kJ/kgK Cp	kJ/kg Phase C	W/m2K Alpha	bar abs Pressure	- Fluid	kg/kg Humidity	- Soft	h TStart	h TStop
Preheating		Cold	20.0	30.0	1.639	3.77	0	200	0	Simple	0	no	0.0	2.0
Discharge		Cold	4.0	50.0	0.139	3.85	0	1000	0	Simple	0	no	2.0	4.0

Fig. 5.4: PinCH E-Module Stream Table

Tab. 5.5: Stream Table Heading Description

Heading	Description	Units
Name	The name of the stream.	–
Segment	This column is left empty - segmentation of condensing streams is automatically done in PinCH.	–
Hot/Cold	Defines if the stream is hot or cold.	–
Tin	Stream inlet temperature.	°C
Tout	Stream outlet temperature.	°C
Flow	Mass flow of the stream.	kg/s.
Cp	Specific heat of the fluid.	kJ/kgK
Phase Change	Specific heat of the fluid when changing phase.	kJ/kg
Alpha	Heat transfer coefficient, depends on the fluid.	W/m ² K
Pressure	Required when other values have to be calculated automatically, i.e. for steam or wet air.	bar(a)
Fluid	“Simple” fluid means that the fluid is defined by c_p , temperature and mass flow. Other fluids, such as “Water” or “HumidAir” will be automatically completed in PinCH with an internal properties library. See PinCH for further explanations regarding the available fluids.	–
Humidity Ratio	Absolute humidity for humid air – ratio of water to dry air.	kg/kg
TStart	Start time of the stream (for batch processes only).	h
TStop	End time of the stream (for batch processes only).	h
To be used in PinCH	Tells the user if the stream will be used in the stream table that will be exported to PinCH	–

5.4 Using E-Modules with PinCH

In this section how to use E-Modules together with the PinCH software will be discussed.

5.4.1 Basics

The first step is to open the “EModule Explorer” window. To open the EModule Explorer window:

- Click **View** on the Menus Toolbar and select **EModules Explorer**

The explorer window should now appear as seen in Figure 5.1. The most important features of the EModule Explorer window is 1. the default EMs in the left-hand side data grid and 2. the working EMs listed in the right-hand side data grid.

1. E-Modules in Library (Left-hand side): This is a list of all available EMs supplied when installing the PinCH software. They are defaults and are not to be modified.
2. Working E-Modules Library (Right-hand side): This data grid list any working EMs that have been either copied from the default EMs or are customized.

5.4.2 Opening and Using E-Modules

Any EM can be opened by simply double clicking on one of the listed EMs in either the default EM listing or the working EM listing. The EM will open automatically in Excel to be used side by side with the PinCH software. Any changes to the EM can be simply done by using the existing standard Save/Save As functionality within Excel.

Default EMs are not to be edited directly but can be copied and stored in the working EM grid listing:

1. Right click on a default E-Module listed in the left-hand side data grid.
2. Select the context menu **Create local copy**

5.4.3 Saving E-Modules

To save any changes made in the EM copy, simply save the file as you would a normal Excel file:

1. Left click on the **File** tab on the ribbon
2. Click **Save**

Alternatively, left click on the save icon as seen circled in red on 5.5:

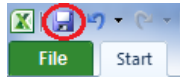

Fig. 5.5: Save Icon

5.4.4 Exporting E-Modules Stream Table to PinCH

Once you are satisfied with the information shown in the EM stream table, the stream table can be exported to PinCH.

To export the EM stream table to PinCH:

1. Create a new Excel file
2. Copy the cells contained within the grey area of the Import Table of the EM (be sure to include the column headers)
3. Paste the copied cells into the new Excel file (paste values only)
4. Save the file in the csv format (**File -> Save as -> Save as type -> CSV (comma delimited)**)
5. In PinCH, use **File -> Import Stream Table** to import the csv file (ensure you have already created a project)

The EM streams should now be a part of the Process Stream Table and ready to use in the PinCH project!

5.5 PinCH/E-Module Fluid Calculation Interface

As a part of the E-Modules, an calculation interface has been developed with the purpose of supporting fluid calculations. The interface links Excel and PinCH via an Excel Add-In. The purpose of the Add-In functions is to facilitate the calculations of certain values that are required for the EM process information state.

In this section only how to use the PinCH Add-Ins will be discussed. For a list of the available functions, the input variables and the output values refer to Appendix A.7.

5.5.1 Uploading PinCH Add-Ins to Excel

The PinCH Add-Ins should be automatically added to Excel when PinCH 3.2 (or higher) is installed. If this is not the case then the following procedure should help the user to upload the Add-Ins to Excel.

To Uploading PinCH Add-Ins to Excel 2016

1. Follow the Path:

Start Excel → File → Options → Add-Ins → Go... → Browse → Program → Microsoft Office → Office 16 → Library

2. When EModuleAddin is highlighted press enter or click the OK button

The PinCH E-Module Add-In should now be ready for use in the EM!

5.5.2 Using the Add-In Functions

1. In an empty cell within a E-Module enter **=pinch**
2. From the contextual menu either:
Double click with the left mouse button on the desired function name
or
Use the ↓ and ↑ keys to navigate to the desired function and press the **Tab** button

3. Enter the cell name(s) or click on the cell(s) that contain the input variable value(s)

or

Enter the input value(s) yourself

or

A combination of cell names and values is also possible

Note: If the function requires more than three inputs then the values should be separated by a semicolon (the Excel default setting). An example of a PinCH Add-In function is displayed in Figure 5.6.

The diagram shows the Excel formula `=PinCH_PureFluid_h_pt(2.5;115.5;"Water")`. A blue arrow labeled "Calculated Value" points to the function name `PinCH_PureFluid_h_pt`. A blue bracket labeled "Input Values (p;t;x)" spans the three arguments: `2.5`, `115.5`, and `"Water"`. A blue bracket labeled "Input Variables" is positioned below the first two arguments, `2.5` and `115.5`.

Fig. 5.6: PinCH Add-In Function in Excel

4. Press the enter key

Upon pressing the enter key the calculated value will appear in the cell in which the Add-In function was entered.

Note: It is very important that you know the units of the input variables and the calculated values as these are not given in the Excel sheet. For a list of the different units used in the Add-In functions see Appendix A.7.

Chapter 6

Configuring the Project

6.1 Introduction

During the data extraction phase (see Chap. 3.1 Fig. 3.1) a structured breakdown of individual processes within an industrial site can be identified. This structure defines the time and space boundaries as well as any limitations to interlinking between these boundaries and other constraints. PinCH supports the configuration and modeling of such structures through the definition of Processes. Processes contain the assignment of the stream requirements that are identified to be encapsulated within a single process.

PinCH also allows the definition of equipment. Each stream can be considered to belong to a piece of equipment that can be taken into consideration when calculating total investment costs where multiple operating cases or batch time slices exist (see sections 8 or 9).

Finally, scheduling on a time basis can be done in order to perform studies such as multiple operating cases analysis. In addition, sets of global economic data can be defined that will be applied across all groupings of processes. These sets contain specific power law cost equation parameters for different heat exchangers as well as general site investment and operational cost parameters. Combined together with the processes as well as the scheduling, the energy-capital trade-off through heat recovery using a heat exchanger network can be calculated before any detailed design (see section 7).

6.2 How to Create and Configure Equipment

Equipment items are the locations where the streams actually exist or flow. They are important for calculating the heat exchanger area that can be reused between multiple operating cases or batch time slices. The mapping of streams between multiple operating cases or batch time slices is done by sharing the equipment. Each stream can be considered to belong to a piece of equipment that can be taken into consideration when calculating total investment costs ensuring common heat exchanges are properly accounted for (see sections 8 or 9).

Note: Pieces of Equipment are automatically assigned and stored under the Individual node on the Project Explorer when a stream is created. A new piece of equipment is only required when there is a need to share it between two or more streams.

To Add a New Equipment:

1. Select the **Project Explorer**.
2. Right click on the Equipment node and select **Create New Shared Equipment**.
3. Select the newly created equipment listed under the Equipment node and press **F2**.
4. Rename the node as required.
5. Select the **Properties** window to set the parameters for selected equipment.

To Share an Equipment Between Streams:

1. Select **a stream** in the Process Stream Table.
2. Select the **Property window** to show the Stream properties.
3. Change the Equipment combo-box value to the desired shared equipment.
4. Repeat steps for a second stream to complete sharing.

6.3 How to Create Processes, Multiple Operating Cases Group and Assign Streams

Create a new process by using the PinCH Project Explorer dockable window. The project explorer encapsulates all the necessary functionality used to define the necessary static information for an industrial site (Fig. 6.1). The most critical first step is to create the processes defined as subsystems of the site and then assign streams.

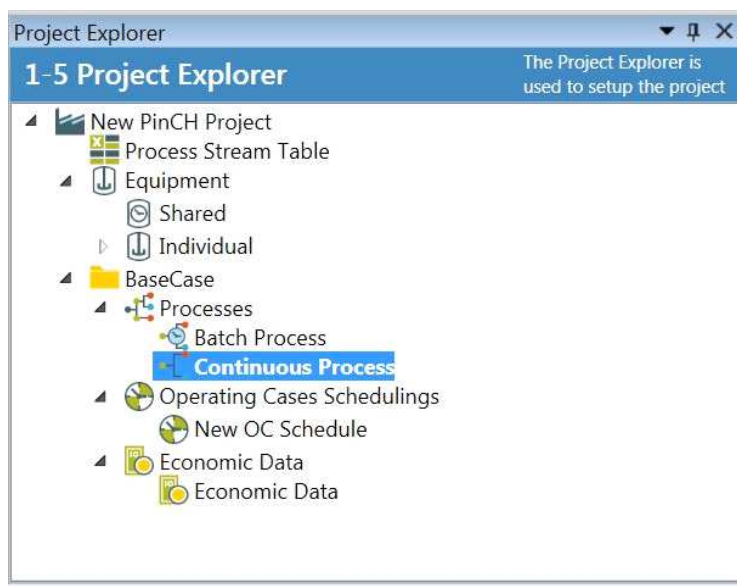

Fig. 6.1: Project Explorer

To create a Process:

1. Select and highlight the **Processes** node in the **Project Explorer**.
2. Right click on the **Processes** node to view the context menu and select **Add Process**.
3. Select the newly created process listed under the **Processes** node and press **F2**.
4. Rename the node as required.

To Assign Streams to a Process:

1. Ensure to first select and highlight a created process listed under the **Processes node** (see Fig. 4.1).
2. Select the **Process Stream Table** tab.
3. Select **a stream** in the upper Stream Table.
4. Click with the left mouse button on the stream and **hold and drag downwards** to the working Stream Table.
5. Release the mouse button to assign the stream to the process.
6. Repeat for the number of streams to be assigned to the process.

Note: More than one stream can be selected by simply holding down the Ctrl button and then selecting the streams as required. By simultaneously pressing the Ctrl and Shift button, multiple streams in a single batch can be selected as commonly done in Windows Explorer.

As reviewed in section 3.3.5 it is possible to configure multiple operating cases consisting of the same streams, but with different states (e.g. summer/winter). In order to use these streams at different states and therefore, have a shared equipment, a Multiple Operating Cases (MOC) Group has to be used. This special type of processes grouping allows for proper calculation of area targets when using the combined supertargeting tool. In addition, the group is needed when using the same streams in multiple processes that do not overlap in time yet need to be assigned to the same Target Group.

To Create a Multiple Operating Cases Group:

- 1 Create two processes as described above.
- 2 Create two streams and share them in the same equipment as shown in section 6.2.
- 3 Assign the two shared streams - one to each process - as described above.
- 4 Assign several other non-shared streams to the two processes as described above.
- 5 Select and highlight the Processes node in the Project Explorer.
- 6 Right click on the Processes node to view the context menu and select **Add Multiple Operating Cases Group**.

- 7 Select the newly created process listed under the Processes node and press **F2**.
- 8 Rename the node as required.
- 9 Right click on the newly added MOC Processes Group and select **Assign Processes...** and select one of the created processes.
- 10 Repeat for the second process to complete the assignment of the MOC processes group.

Note: The processes can be automatically assigned or de-assigned from the MOC group as required. The assignment is important to ensure that streams are never allowed to overlap in time, yet still allow the configuration of different operating states of the same process. PinCH automatically performs the checks as needed and resets the schedule of each process if an overlap in process times occurs.

6.4 How to Create and Configure Operating Case Schedules

Schedules are used to configure the time dependency of either continuous or batch processes. This step is important in ensuring the correct operational times and the resulting operational costs are calculated.

To create a schedule or sets of schedules, the Operating Cases Scheduling node within the Project Explorer node can be used. On this dialog are given the fields to set the time dependent data for configuring either a continuous, semi-continuous or batch process.

To create a New Operating Case Schedule:

1. Ensure at least one continuous or batch process has been added (see section 6.3).
2. Select and highlight the Operating Cases Scheduling node in the Project Explorer.
3. Right click on the Operating Cases Scheduling node to view the context menu and select **Add Operating Cases Scheduling**.

4. Select the newly created schedule listed under the Operating Cases Schedules node and press F2.
5. Rename the node as required.
6. For continuous processes change the TimeBase combo-box from Cont. Yearly to Cont. Weekly or Cont. Daily to designate as semi-continuous. Modify the time parameters as required.
7. For batch processes change the TimeBase combo-box to change between batch schedules daily, weekly or yearly basis. Modify the time parameters as required (see section 9.2.2).

On the Operating Cases Scheduling visualizer are several data grids and graphics. The user can enter the configuration data in one data grid for either a continuous/semi-continuous process or in another data grid for batch processes. In addition, the overall Gantt chart as well as the weekly production campaign chart can be viewed. These charts help the user to graphically see the data configured in the two data grids to ensure correct data entry. Finally, for batch processes the equipment-wise repeat operation period Gantt chart is also available to provide a check on the configured batch stream data (tstart and tstop values). Fig. 6.2 illustrates the operating case scheduling for multiple continuous processes.

As shown in Figure 6.2 a Continuous Processes data grid is shown that must be used to configure the necessary scheduling data of each individual process (refer to section 9.2 for how to schedule a batch process). The data shown in the continuous scheduling grid are summarized in the following Table 6.1.

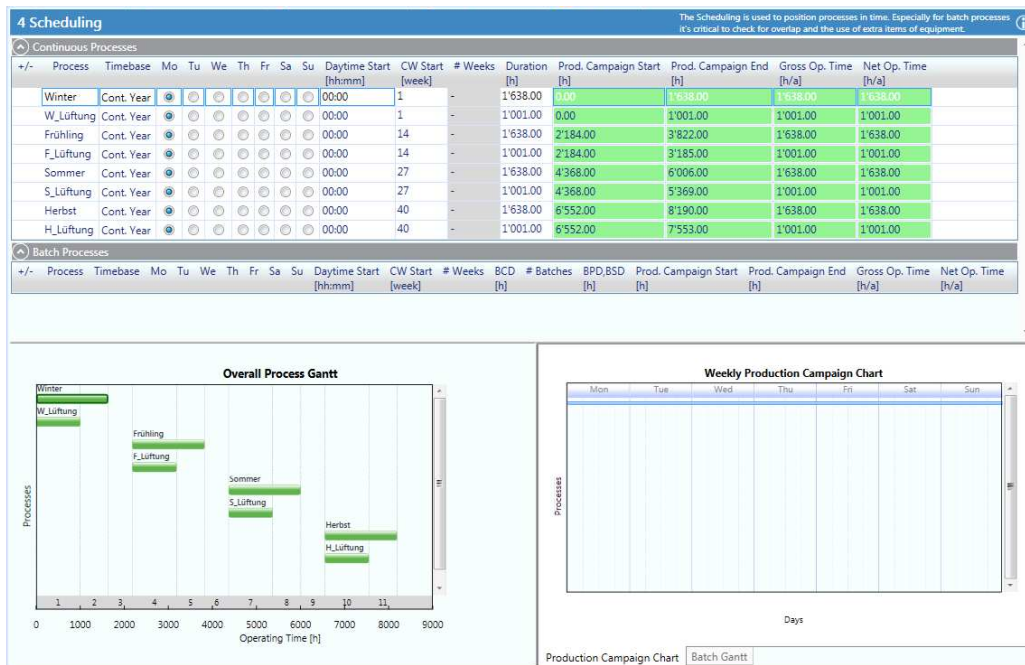

Fig. 6.2: OC Scheduling showing several continuous processes over one year

Tab. 6.1: Continuous Process Operating Cases Scheduling Data Grid Values Table

Scheduling Grid Values	Description	Units
Process	The name of each process to be scheduled as defined in the project explorer.	
Time Base	The selected type of continuous process either continuous (Cont. Year) or semi-continuous (Cont. Weekly or Cont. Daily)	
Mo	Monday - Selected day of the week to either start a continuous process or the day of the week a semi-continuous process is in operation.	
Tu	Tuesday - Selected day of the week to either start a continuous process or the day of the week a semi-continuous process is in operation.	
We	Wednesday - Selected day of the week to either start a continuous process or the day of the week a semi-continuous process is in operation.	
Th	Thursday - Selected day of the week to either start a continuous process or the day of the week a semi-continuous process is in operation.	
Fr	Friday - Selected day of the week to either start a continuous process or the day of the week a semi-continuous process is in operation.	
Sa	Saturday - Selected day of the week to either start a continuous process or the day of the week a semi-continuous process is in operation.	
Su	Sunday - Selected day of the week to either start a continuous process or the day of the week a semi-continuous process is in operation.	
Daytime Start hh:mm	The actual start time in the selected week given in hours and minutes of the day.	hh:mm
CW Start	The calendar week in the year on which the process starts.	
No. Weeks	The number of weeks a semi-continuous processes is in operation (Cont. Weekly or Cont. Daily).	
CW Start	The calendar week in the year on which the process starts.	
Duration	Either the yearly duration of single continuous process or the weekly/daily duration of a semi-continuous process.	h

Continuation of Tab. 6.1:

Scheduling Grid Values	Description	Units
Prod. Campaign Start	The calculated absolute start time in the year for the selected process.	h
Prod. Campaign End	The calculated absolute end time in the year for the selected process.	h
Gross Op. Time	The calculated time difference between the absolute start and end time over the year.	h/a
Net Op. Time	The actual time in operation of the selected selected process over the year.	h/a

6.5 How to Create and Configure Global Economic Data

The Project Explorer can also be used to define different versions or sets of the global economic data as shown in Figure 6.3.

On this entry dialog are given the heat exchanger power law equation parameters for process-process, cold utility-process and hot utility-process stream matching. In addition, the global energy prices as well as general site wide operational and investment costs are given. These cost parameters are used together in deriving the targeting cost result based on the area and number of units distributions as shown in Appendix A.1.

Note: The default cost base factor Cb shown in Figure 6.3 contains an installation factor of three for each of the heat exchangers shown. The value is based on standard carbon steel construction typical of the early 1990's. Nevertheless, it is always an important task during a pinch analysis to determine relevant cost data for the appropriate time frame and materials of construction.

5 Economic Data

The economic Data data is used throughout the software PinCH for calculating the main costs associated with an heat exchanger network (HEN).

Heat Exchanger Costs

$$C = C_0 + C_b(A/A_b)^m$$

A = Heat Exchanger Area [m²]

Type	Fixed Cost C ₀ [CHF]	Base Cost C _b [CHF]	Base area A _b [m ²]	Exponent m [-]
Process Heat Exchanger Costs	0	120000	100	0.71
Hot Utility Heat Exchanger Costs	0	120000	100	0.71
Cold Utility Heat Exchanger Costs	0	120000	100	0.71
JSSP Heat Exchanger Costs	0	120000	100	0.71

Storage: Tank Costs

$$C = C_0 + C_b(V/V_b)^m$$

V = Tank Volume [m³]

Storage	Fixed Cost C ₀ [CHF]	Base Cost C _b [CHF]	Base volume V _b [m ³]	Exponent m [-]	Storage Type
FTVM	0	150000	100	0.71	FTVM
Stratified	0	150000	100	0.71	Stratified

Storage: Media Costs and Media Properties

$$C = C_b \times Q$$

Q = Storage Media [kg]

Media	Base Cost C _b [CHF/kg]	Density [kg/m ³]	Alpha [W/(m ² *K)]	C _p [kJ/(kg*K)]
Water	0.001	1000	2000	4.18789
Heat Transfer Oil	5	800	1000	2.00000

Amortisation Parameters

Pay off period: y Independent: CHF

Interest rate: % Personnel: %/y IC

Annuity: 0.282 1/y Maintenance: %/y IC

Electricity

note: Utility Costs Are Set on Utility Stream Table Electricity Cost: CHF/MWh Electric Power: kW

Fig. 6.3: Global Economic Data dialog that centralizes all investment and plant related cost parameters (note: specific utility cost are on the Utility Stream Table)

How to Create New Global Economic Data:

1. Select and highlight the **Economic Data** node in the Project Explorer.
2. Right click on the Economic Data node to view the context menu and select **Add Economic Data**.
3. Select the newly created economic data listed under the Economic Data node and press **F2**.
4. Rename the node as required.
5. Change the parameters as required.

Note: The annuity factor is calculated and updated automatically once a new Pay off Period or Interest Rate is entered.

Chapter 7

Analyzing Single Continuous Processes

7.1 Introduction

Targeting calculations are a central part of a pinch analysis study. The significance of such calculations lies in the fact that a great deal of useful information can be calculated using only the stream based data established in the data extraction and energy modeling efforts. No detailed design needs to be completed at this part of the study which allows for rapid iterations in evaluating heat integration possibilities.

The main goal of the targeting calculations is to establish the optimum cold and hot utility requirements for a given set of process requirements as established during the data extraction phase (see section 4). In addition, the area and number of units distribution can also be established. The thermal, economic and time dependence data configured in the project explorer (see section 6) provide the foundation for these calculations and link the thermodynamic requirements with the economic realities. The theory and fundamental equations used in targeting calculations are not covered in the following sections. However, the user is recommended to review the following references for more information: [5 - 10].

In the PinCH software, several key application components are used for creating and analyzing targeting results. The first is the Target Group where specific economic data, schedules, processes and utilities can be selected to calculate a Target Result. These components provide the basis for creating scenarios used in the iterative procedure often necessary for determining the

most relevant target result. The details of these and other components are presented in the next sections.

Note: The following sections are for a single continuous process. See section 8, 9 and 10 for information related to multiple operating cases and batch processes.

7.2 How to Create and Configure a Target Group

A new Target Group can be created using the Target Explorer. A Target Group represents in principle a grouping of scenarios and encapsulates all the necessary functionality used in configuring and calculating the dynamic information used in analysis (Fig. 7.1). The first step is to create a grouping of processes that are to be analyzed within a Target Group. More than one process can be selected which enables the analysis of processes that exist at the same time (i.e. zonal targeting assessment) or that for multiple operating cases (MOC - see section 8).

Note: Streams are not allowed to be added to the same Target Group more than once and the user will be prevented from doing so automatically!

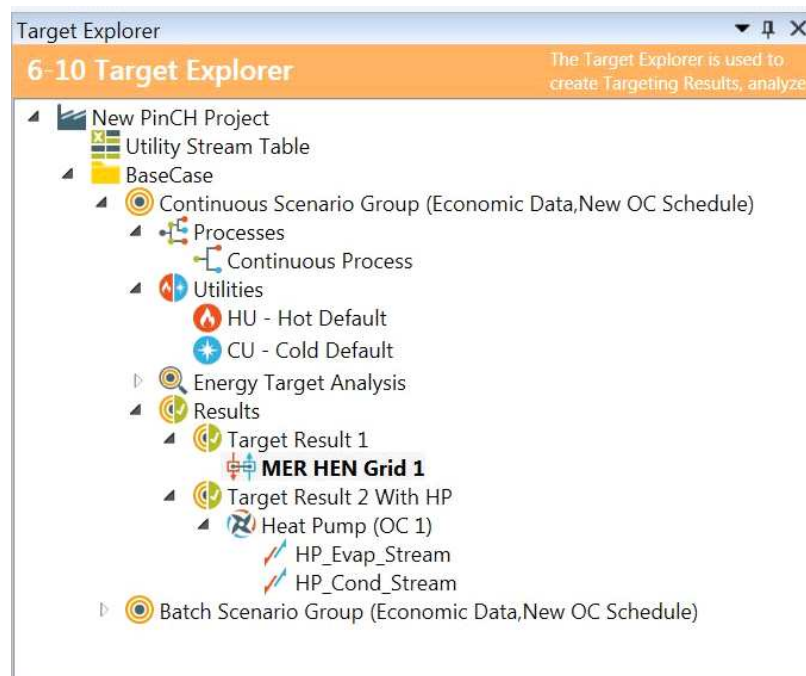

Fig. 7.1: Target Explorer

To create a Target Group:

1. Select and highlight the **BaseCase node** in the Target Explorer.
2. Right click on the **BaseCase node** to view the context menu and select **Add Target Group**.
3. Select the newly created Target Group listed under the **Processes node** and press **F2**.
4. Rename the node as required.

7.3 How to Create a Target Result

A Target Result is the central calculation object created when calculating the energy, area and unit targets used in performing a pinch analysis. However, as reviewed in section 3, there can exist differences in the time dependent nature of the underlying process streams that can result in two main result types - continuous and batch/multiple operating case (MOC). In the following subsections only a single continuous process target result is created. Please see sections 8 and 9 for information related to multiple operating cases and batch processes.

Continuous target results consist primarily of a single process or a grouping of multiple processes that are synchronized in time. All streams exist over the same time duration resulting in the creation of a single composite curve. Analysis is straightforward as it is assumed that each stream can potentially exchange energy with all other streams of the opposite hot or cold designation.

Create a Target Result for a Continuous Process:

1. Create a **Target Group**.
2. Select and highlight the Target Group node in the Target Explorer.
3. Right click on the Target Group node to view the context menu and select **Reassign Operating Cases Schedule** and re-assign a schedule as needed.
4. Right click on the Target Group node to view the context menu and select **Reassign Economic Data** and re-assign an economic data as needed.

5. Right click on the **Processes node** and select a process to be used in the analysis. Repeat for any additional processes to be combined together for the analysis.
6. Right click on the **Utilities node** and select a default hot and a default cold utility (see note given below).
7. Right click on the **Results node** and select **Calculate Target Result with... > Separate Design** to create the target result.
8. All the nodes can be renamed after pressing F2.

Note: It is critical to have created at least one hot and one cold stream in the Utility Stream Table. Please be certain to ensure the respective temperature ranges of these utilities provide enough driving force for the given process streams. These two utilities will need to be assigned as the default hot and cold utility in order to allow the internal energy balance to be closed. This is particularly important in the case of adding multiple utilities used in optimizing such systems.

After completing the above, a window will be created and anchored on the workbench with a tab. This window encapsulates the entire targeting result for the selected tool (in this case the Separate Design Tool) (Fig. 7.2). By selecting check boxes on the OC Charts header, the composite curve, grand composite curve, balance composite curve, balanced grand composite curve, cost curve as well as the Gantt chart can be selected. Each will display automatically in the upper portion of the window while the specific targeting result for a given ΔT_{min} is shown and is editable on the OC Data grid at the bottom of the window. The results for the composite curve (only includes the default hot and cold utility) and the balanced composite curve (includes the default hot and cold utility as well as any additional internal sized utilities) are shown on the Results Panel.

A summary row has been included to show the cumulative sum over all the OCs or TSs for the area, number of units and all the costs based only on the default utilities. If internal utilities have been assigned then two rows per OC or TS are shown to show the difference in targets (CC and BCC). If no internal utilities are assigned then only the composite curve (CC) result is shown.

Heat flow values for internal utilities (i.e. non-default) can be entered directly in a Target Result to show the effect on the composite curves. Typically this is done to assess the cost effect of using an optimized set of utilities or to

assess the effect of the existing utilities. See section 7.5 for more information on how to enter heat flow values for internal utilities.

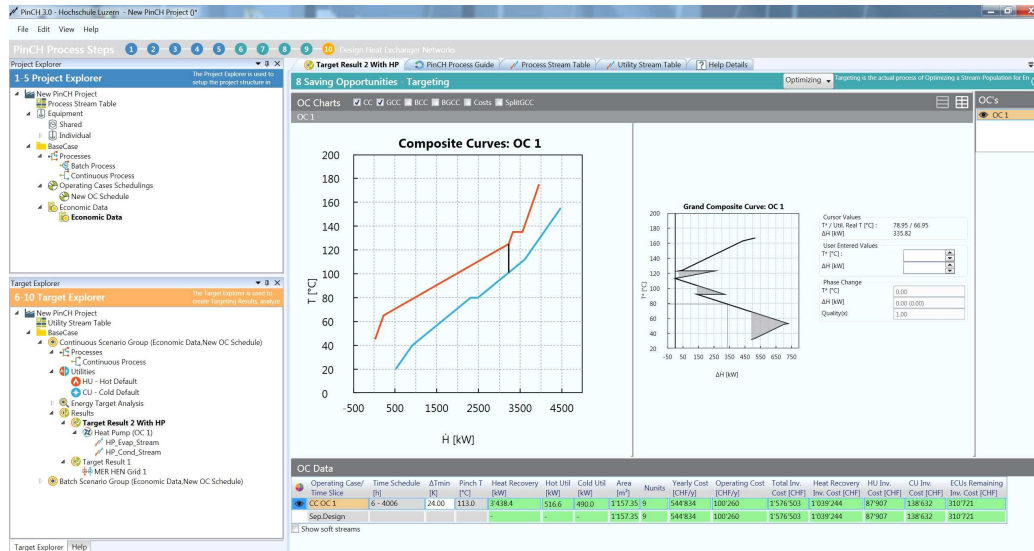

Fig. 7.2: Continuous process Separate Design tool Target Result

7.4 How to Manage Targeting Results

One of the key advantages of the Targeting Explorer is the flexibility it gives to compare different Target Results. For any particular Target Group multiple Target Results can be created and then automatically saved under the particular Target Group tree node. A structure of test cases can be saved directly and easily used in comparing the results of each to find the best heat integration option.

Creating Multiple Target Results:

1. Create a Target Result as described in subsection 7.3.
2. Right click on the **Results** node and select **Calculate Target Result with... > Separate Design** to create a second target result.
3. All the nodes can be renamed after pressing F2.
4. Change the ΔT_{min} in the new Target result to a different value.

5. Repeat for required number of different ΔT_{min} values.

Note: Additional target results can be created when an ECU (see section Energy Conversion Unit), soft streams or multiple utilities (see section 4) are included with a particular Target Result.

Comparing Multiple Target Results:

1. Create Multiple Target Results as described earlier.
2. Right click on each of the created target result nodes and select **Open Target Result with Separate Design**.
3. Ensure all the target results windows are displayed as tabs in the center docked position.
4. Left click on one of the target result tabs and **hold and drag** to reposition. The dockable window anchor points (circled in red in Figure 7.3) will be displayed on the workbench.
5. Position the cursor while dragging over the right most anchor point.
6. The target result window will be placed beside the other target results still in the original center position (see Figure 7.4).
7. Reposition the window edges by clicking with the left button to shift the edges.

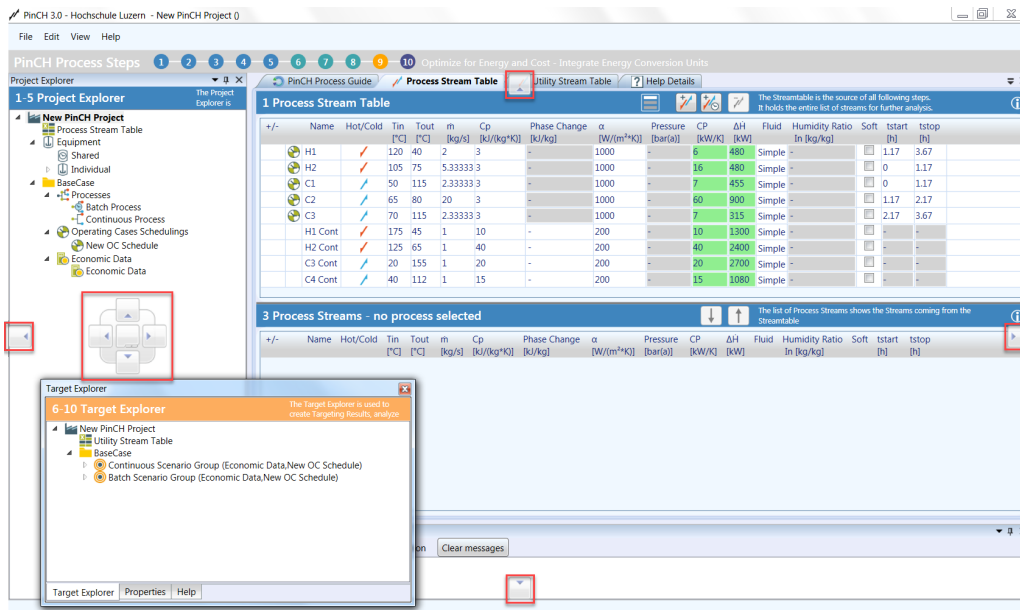

Fig. 7.3: Dockable window repositioning possibilities (note: Window anchor points are shown in red squares)

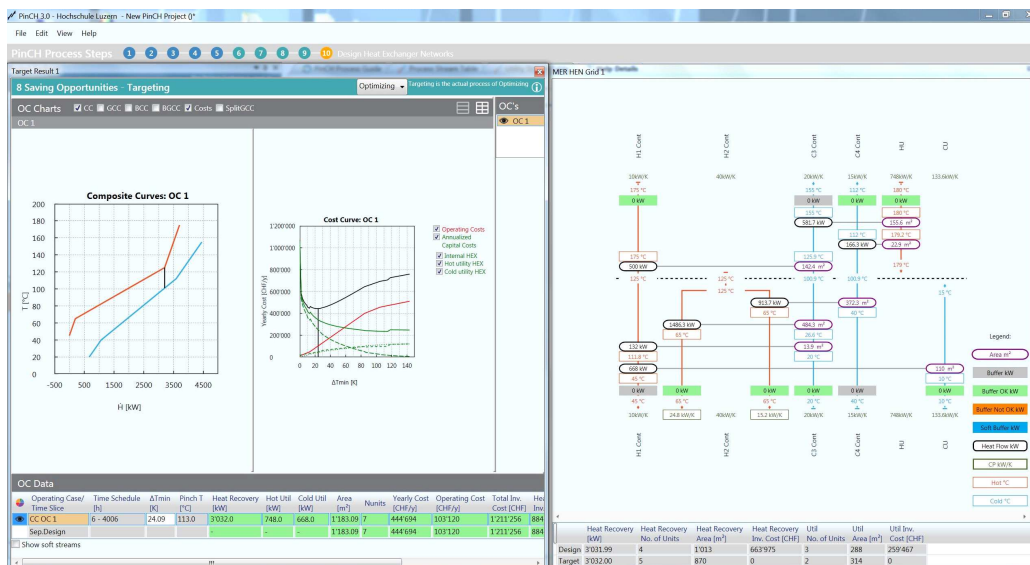

Fig. 7.4: Two dockable windows positioned side-by-side to allow comparison of Results (e.g Target Result and associated HEN Grid design)

The management of Target Results also includes the handling of changes to the underlying data that affect a result. In PinCH any change such as a stream table parameter change, economic data change or schedule change will result in the previously saved Target Results no longer being

synchronized with the changed data. In most cases open Target Results will be automatically synchronized when a change in for example the stream table is made. However, changing a utility stream alpha will not be automatically updated and will require the Target Result to be manually synchronized by closing and re-opening the Target Result.

Handling Changes to Data That Affect Target Results:

1. Create a **Target Result**.
2. Change a stream table parameter in the Process Stream Table for one of the streams in the process.
3. A message box confirming the change results is displayed (Fig. 7.5). Select **Yes**.
4. The HEN Grid icon is displayed in red to indicate it is no longer synchronized with the underlying stream data (also when the ΔT_{min} is changed).

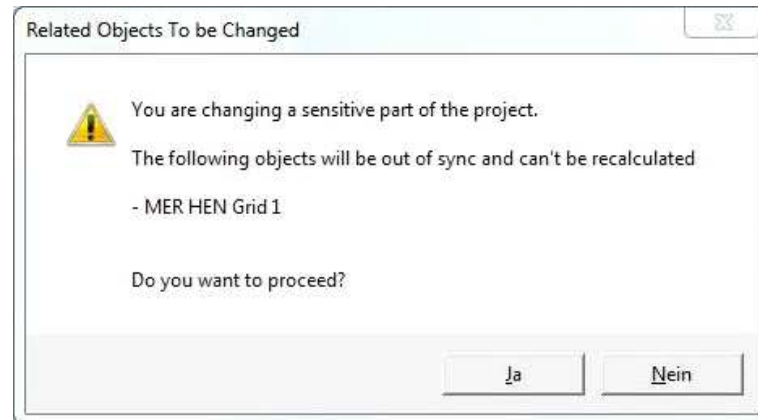

Fig. 7.5: Dialog confirming change that affects all dependent Target Results

7.5 Analyzing Results

The data derived from a Target Result can be viewed either on the OC Charts displayed or in the OC Data grid shown at the bottom of the window containing each Target Result (see Fig. 7.2). The charts include the Composite Curve (CC), Grand Composite Curve (GCC), Balanced Composite

Curve (BCC), Balanced Grand Composite Curve (BGCC), Cost Curves and the Split Grand Composite Curve (Split GCC). The cost curves include a breakdown of the annual investment cost curve into the investment cost for internal process-process heat exchangers, CU-process heat exchangers and HU-process heat exchangers.

Several characteristics related to the OC Data are to be noted regarding the display. First there are two rows displayed for a single operating case or time slice. Fig. 7.6 shows the two rows. The first row corresponds to the targeting result information based on the CC graph where only the default hot and cold utilities are added at the end of the composite curve. No other utilities are allowed. The second row is optional and is based on the balanced composite curve (BCC) that includes any internal utilities (in addition to the default utilities) that have been included in the composite curve. This data row is only shown when one additional utility outside of the default utilities has been included and sized (based on the GCC).

OC Data															
Operating Case/ Time Slice	Time Schedule [h]	ΔT_{min} [K]	Pinch T [°C]	Heat Recovery [kW]	Hot Util [kW]	Cold Util [kW]	Area [m ²]	Nunits	Yearly Cost [CHF/y]	Operating Cost [CHF/y]	Total Inv. Cost [CHF]	Heat Recovery Inv. Cost [CHF]	HU Inv. Cost [CHF]	CU Inv. Cost [CHF]	ECUs Remaining Inv. Cost [CHF]
CC OC 1	0 - 6000	14.00	77.0	596.0	579.0	194.0	240.84	8	457'321	312'840	393'681	298'487	48'562	46'632	0
BCC OC 1	0 - 6000	14.00	77.0	596.0	579.0	194.0	240.84	8	457'321	312'840	393'681	298'487	48'562	46'632	0
Sep.Design				-	-	-	240.84	8	457'321	312'840	393'681	298'487	48'562	46'632	0

Fig. 7.6: Result panel for a continuous process Target Result with a single operating case and two rows for CC and BCC when multiple internal utilities are defined

Adding and Sizing Internal Utilities:

The default utilities (both hot and cold) must always be added to a Target Group. This ensures that the energy balance for each associated Target Result can be completed and the proper costs can be calculated. In order to include multiple “internal” utilities, additional hot and cold utilities can be added to the Utility Stream Table and assigned to the Target Group along with the default hot and cold utilities. These internal utilities can then be sized. The heat flow of each internal utility must be specifically set and can be typically derived from the GCC.

How to Size Internal Utilities:

1. Create a Target Result as described in section 7.3.
2. Add an additional utility stream to the Utility Stream Table.
3. Assign the newly added utility stream to the Target Group.
4. Add a new Separate Design Target Result.

5. Right click on the CC row within the OC Data or TS data grid and select **Size Utilities**. Optionally, the properties window tab can be first selected and then the CC or BCC row selected to display the Cold Utility/Hot Utility Sizing text entry boxes.
6. Enter a heat flow value for the internal utility in the associated text entry box. The balanced composite curve will update accordingly (the composite curve only contains the default utilities so it will not change).

A second characteristic of the results panel is that results are shown for each operating case or time slice determined to exist over the entire time period of operation of all processes. Figure 7.7 illustrates the layout of results from a batch process showing the five operating cases and their individual targeting values. In addition, the totals for the targeting values when multiple operating cases or time slices exist are given at the bottom of the data grid.

TS Data		<input checked="" type="checkbox"/> Show Ignored TS													
Operating Case/ Time Slice	Time Schedule [h]	ΔT_{min} [K]	Pinch T [°C]	Heat Recov [kW]	Hot Util [kW]	Cold Util [kW]	Area [m ²]	Nunits	Yearly Cost [CHF/y]	Operating Cost [CHF/y]	Total Inv. Cost [CHF]	Heat Recovery Inv. Cost [CHF]	HU Inv. Cost [CHF]	CJ Inv. Cost [CHF]	ECUs Remaining Inv. Cost [CHF]
CC TS 1	7.8350 - 8.1700	10.00	55.0	840.0	515.0	120.0	130.91	5	72214	161	179236	124565	25576	29095	0
CC TS 2	8.1700 - 9.0050	10.00	100.0	580.0	190.0	380.0	126.16	7	76570	190	189999	119022	14331	56646	0
CC TS 3	9.0050 - 9.6700	10.00	70.0	540.0	675.0	420.0	128.59	6	74755	446	184848	74148	33252	77447	0
CC TS 4	9.6700 - 10.0050	10.00	55.0	840.0	515.0	120.0	130.91	5	72214	161	179236	124565	25576	29095	0
CC TS 5	10.0050 - 10.8400	10.00	100.0	580.0	190.0	380.0	126.16	7	76570	190	189999	119022	14331	56646	0
CC TS 6	10.8400 - 11.5050	10.00	70.0	540.0	675.0	420.0	128.59	6	74755	446	184848	74148	33252	77447	0
Sep.Design				-	-	-	771.33	36	447077	1595	1108164	635471	146319	326375	0

Fig. 7.7: Result panel for a batch process Target Result with multiple operating cases or time slices

The targeting values listed in these panels are summarized in Table 7.1:

Tab. 7.1: Results Panel Targeting Values Table

Results Panel Values	Description	Units
Operating Case/ Time Slice	The time slice in which specific streams exist at the same time	
Time Schedule	The absolute start and end time of an operating case or time slice	hour
ΔT_{min}	The vertical distance between the hot and the cold composite curve at the closest point	K
Pinch T	The pinch temperature represented by the closest approach of the hot and the cold composite curve	°C
Heat Recovery	The amount of heat exchange between process-process or internal utility-process streams	kW
Hot Util	The minimum amount of hot utility needed for heating based on the specified ΔT_{min} for the given composite curves	kW
Cold Util	The minimum amount of cold utility needed for cooling based on the specified ΔT_{min} for the given composite curves	kW
Area	The amount of heat exchanger area calculated based on the given composite curves and ΔT_{min} assuming vertical heat transfer for the spaghetti network [12]	m ²
Nunits	The total number of units calculated based on the given composite curve and ΔT_{min}	[-]
Yearly Cost	The total annual cost for the given composite curve and ΔT_{min}	CHF/ year
Operating Cost	The total annual operating cost for the given composite curve and ΔT_{min} (Utility, ECU and Site Electricity, maintenance and personnel)	CHF/ year
Total Investment Cost	The total cost of the required heat exchanger area plus any remaining ECU investment cost (e.g. compressor cost)	CHF

Continuation of table 7.3:

Results Panel Values	Description	Units
Heat Recovery Investment Cost	The heat exchanger investment cost associated with process-process or internal utility-process streams heat exchange	CHF
HU Inv. cost	The heat exchanger investment cost only associated with the default hot utility-process heat exchange	CHF
CU Inv. cost	The heat exchanger investment cost only associated with the default cold utility-process heat exchange	CHF
ECUs Remaining Inv. Cost	Investment cost for ECUs not including the heat exchanger investment costs for ECUs. (Note: ECU heat exchanger investment costs are included directly in the Energy Recovery Investment cost calculation)	CHF

The results from a Target Result can be analyzed in two ways - i) within the PinCH program itself or ii) exported to another program. The first method is accomplished using the Results Panel and graphics as previously discussed. However, all data grids and graphics can be exported to other programs.

To Export OC Data Grid Table:

1. Calculate and Show a Target Result.
2. Press the ctrl button and then select the desired rows, which will be exported (the selected rows will be highlighted).
3. Press Ctrl + C to copy the selected rows.
4. Open an editing program such as Excel.
5. Press Ctrl + V to paste the results into the program for editing.

To Export Graphics:

1. Calculate and Show a Target Result.
2. **Right-click** on the composite curve graph and select **Save Image As**.
3. Navigate to the desired directory location, enter a name for the png file and press save.

Note: All graphics in PinCH can be saved using the Save Image As context menu directly on each graphic by right clicking.

To Change Scaling of Graphics:

Each graphic can be analyzed in closer detail by changing the scale of the graphic in order to zoom closer in on a particular graph region. This can be done simply by positioning the mouse cursor over a graph at a required location and then using the mouse wheel to increase or decrease the scaling in the chosen region.

7.6 Targeting Analysis Support Tools

One support tool is the interaction tool or cross-hairs implemented for the Grand Composite Curve (GCC). This tool provides the ability to measure the net heat rate at a given shifted temperature or conversely the shifted temperature for a given net heat rate (Figure 7.8). In addition, if a stream consists of a phase change, then this segment can be directly selected. This action allows the setting of the quality value and displays the corresponding shifted temperature and heat rate portion. This functionality is primarily used for sizing internal utilities heat rates when performing a utility system optimization (see section 4).

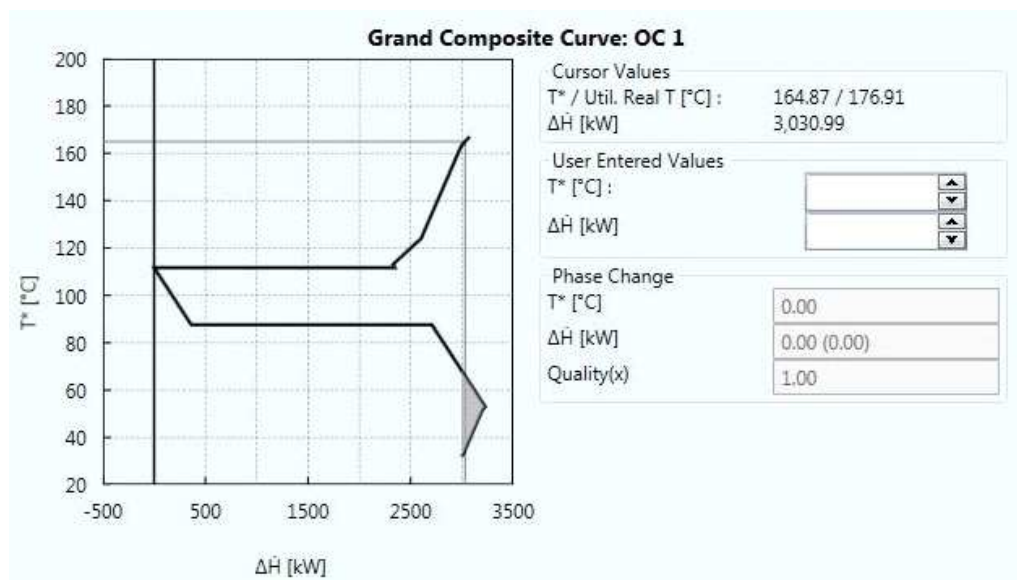

Fig. 7.8: Grand Composite Curve interaction tools to determine accurately shifted temperature or heat flow values

A second tool is the ability to export the internal match-wise area calculation results for each Target Result. These results are exported based on a range of ΔT_{min} values and are saved as a comma-separated values format file. This file can be easily opened in any editing or mathematical program such as Matlab.

To Export Area Matrices:

1. Create a **Target Result**
2. Right-click on the created Target Result node and select **Export > Export Matchwise Result Matrices**

3. Select the operating case to vary the ΔT_{min}
4. Enter a range of ΔT_{min} values to calculate the match-wise matrices
5. Select **Export** button and enter name and location
6. Press **Save**

Another support tool is the ability to Zoom in or out on most of the charts displayed in the software by simply using the mouse wheel. This action causes the axis to update and become more refined allowing the user to see more precise values in the particular chart.

An interesting support tool is the Carnot Factor curves or exergy composite curves. This diagram is based on the composite curves but with the temperature axis replaced by the Carnot factor, $\eta_c = 1 - T_o/T$. The area between the two balanced exergy composite curves is the total exergy loss in the HEN.

To Display the Carnot Factor Curves:

1. Create a **Target Result**
2. Right-click on the created Composite Curve Graph and select **Switch axis to carnot factor**

A final support tool is the ability to Zoom in or out on most of the charts displayed in the software by simply using the mouse wheel. This action causes the axis to update and become more refined allowing the user to see more precise values in the particular chart.

Chapter 8

Analyzing Multiple Operating Cases

8.1 Introduction

As for a single continuous process, targeting calculations involving combinations of continuous or semi-continuous processes play a central role in a pinch analysis study. However, in this case the system boundary is extended to include combinations of continuous processes. The combinations commonly include those processes that run at the same time but are separated (e.g. distance, product, etc.). A second category includes those processes that are only partially overlapped in time and form separate operating cases (OCs) each with different groupings of the available streams. A third category are those processes that exhibit different operating states (e.g. product changes, seasonal changes, etc.) in the same equipment. Section 3.3 shows several options for modelling different process types and how separate operating cases can form.

The importance of such calculations involving these processes lies in the fact that a greater potential for heat transfer is possible given the extended system boundary. However, greater attention to the design of the heat exchanger network is required to ensure investment cost is minimized through the re-use of heat exchanger area between the different OCs. Nevertheless, similar to single continuous process analysis, a great deal of useful information can be calculated immediately using only the stream data established in the data extraction and energy modeling step. No detailed design needs to be completed at this part of the study which allows for rapid iterations in evaluating heat integration possibilities.

8.2 How to Schedule Multiple Operating Cases

Multiple operating cases (MOCs) are formed by the combination of several continuous or semi-continuous processes. In section 3.3 several options for modelling the process types are shown and how separate operating cases can form. PinCH provides real world scheduling capability to model most of the process types encountered in industry.

8.2.1 Standard Multiple Operating Cases

Standard multiple operating cases (MOCs) are formed by the overlap of single continuous processes each of which have different schedules over the course of a year. Specifically shown in sections 3.3.2, 3.3.3 and 3.3.4 are several common types of MOC scheduling configurations. A more complex scheduling is as shown in Figure 8.1 which illustrates the overlap of multiple continuous processes over an entire year based on seasonal variation.

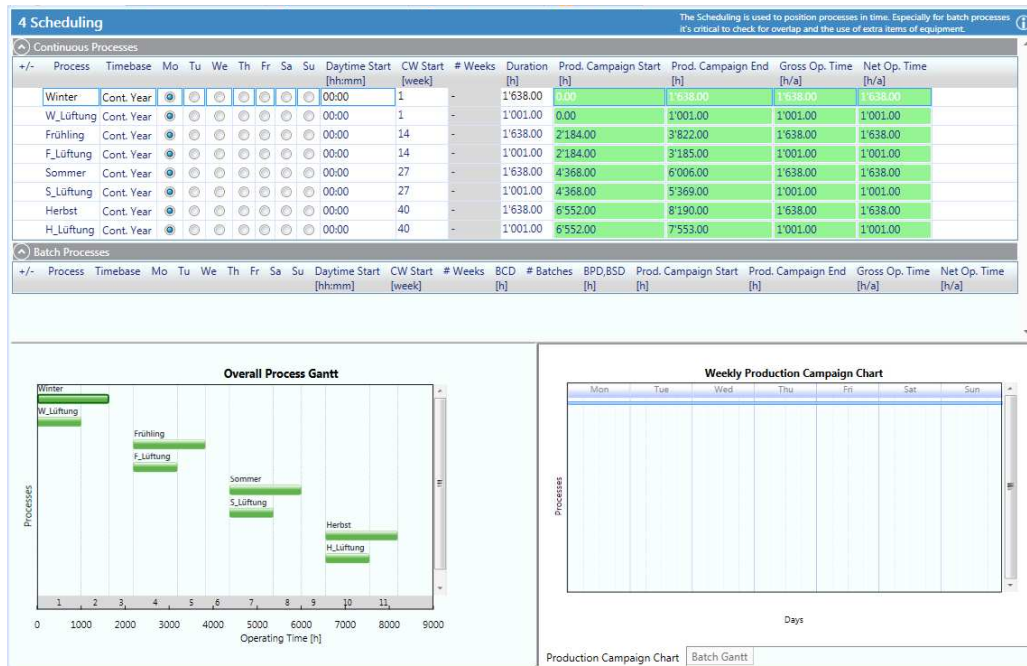

Fig. 8.1: OC Scheduling showing multiple operating cases (MOCs) over the duration of a year and the weekly production campaign for one of the selected processes.

In Figure 8.1 a Continuous Processes data grid is shown, which must be used to configure the necessary scheduling data of each individual process (refer

to section 9.2 for how to schedule a batch process). The data shown in the continuous scheduling grid are summarized in the following table 8.1.

Tab. 8.1: Continuous Process, Operating Cases, Scheduling and Data Grid Values Table

Scheduling Grid Values	Description	Units
Process	The name of each process to be scheduled as defined in the project explorer.	
Time Base	The selected type of continuous process either continuous (Cont. Year) or semi-continuous (Cont. Weekly or Cont. Daily)	
Mo	Monday - Selected day of the week to either start a continuous process or the day of the week a semi-continuous process is in operation.	
Tu	Tuesday - Selected day of the week to either start a continuous process or the day of the week a semi-continuous process is in operation.	
We	Wednesday - Selected day of the week to either start a continuous process or the day of the week a semi-continuous process is in operation.	
Th	Thursday - Selected day of the week to either start a continuous process or the day of the week a semi-continuous process is in operation.	
Fr	Friday - Selected day of the week to either start a continuous process or the day of the week a semi-continuous process is in operation.	
Sa	Saturday - Selected day of the week to either start a continuous process or the day of the week a semi-continuous process is in operation.	
Su	Sunday - Selected day of the week to either start a continuous process or the day of the week a semi-continuous process is in operation.	

Continuation of table:

Scheduling Grid Values	Description	Units
Daytime Start hh:mm	The actual start time in the selected week given in hours and minutes of the day.	hh:mm
CW Start	The calendar week in the year at which the process starts.	
No. Weeks	The number of weeks a semi-continuous process is in operation (Cont. Weekly or Cont. Daily).	
Duration	Either the yearly duration of single continuous process or the weekly/daily duration of a semi-continuous process.	h
Prod. Campaign Start	The calculated absolute start time in the year for the selected process.	h
Prod. Campaign End	The calculated absolute end time in the year for the selected process.	h
Gross Op. Time	The calculated time difference between the absolute start and end time over the year.	h/a
Net Op. Time	The actual operation time of the selected process over the year.	h/a

8.2.2 Semi-Continuous Processes and Multiple Operating Cases

As noted in Table 8.1 a semi-continuous process can be defined by selecting a TimeBase of Continuous Weekly or Continuous Daily. The user can enter the configuration data in the data grid for either a continuous or a semi-continuous process. The data entry fields in the continuous scheduling grid change slightly in order that the operation of a process can be specified for a fixed number of hours over the time period of one week or over a specific day of the week. (see Fig. 8.2)

Several charts are available for analysis in the Operating Cases Scheduling visualizer as shown in figure 8.1. The charts include the Overall Process Gantt chart as well as the Weekly Production Campaign chart. These charts help the user to graphically view the data configured in the two data grids to ensure correct data entry.

The Weekly Production Campaign chart is particularly helpful as it graph-

Continuous Processes																	
+/-	Process	Timebase	Mo	Tu	We	Th	Fr	Sa	Su	Daytime Start [hh:mm]	CW Start [week]	# Weeks	Duration [h]	Prod. Campaign Start [h]	Prod. Campaign End [h]	Gross Op. Time [h/a]	Net Op. Time [h/a]
	Continuous Process	Cont. Year	<input type="radio"/>	<input type="radio"/>	<input type="radio"/>	<input type="radio"/>	<input type="radio"/>	<input type="radio"/>	<input type="radio"/>	06:00	1	-	4'000.00	6.00	4'006.00	4'000.00	4'000.00
	Semi-Continuous Process	Cont. Daily	<input checked="" type="checkbox"/>	<input checked="" type="checkbox"/>	<input checked="" type="checkbox"/>	<input checked="" type="checkbox"/>	<input type="checkbox"/>	<input type="checkbox"/>	<input type="checkbox"/>	04:00	1	30	14.00	4.00	5'044.00	5'040.00	1'680.00

Batch Processes																			
+/-	Process	Timebase	Mo	Tu	We	Th	Fr	Sa	Su	Daytime Start [hh:mm]	CW Start [week]	# Weeks	BCD [h]	# Batches	BPD,BSD [h]	Prod. Campaign Start [h]	Prod. Campaign End [h]	Gross Op. Time [h/a]	Net Op. Time [h/a]
	Batch Process	Batch Daily	<input checked="" type="checkbox"/>	<input checked="" type="checkbox"/>	<input checked="" type="checkbox"/>	<input checked="" type="checkbox"/>	<input checked="" type="checkbox"/>	<input type="checkbox"/>	<input type="checkbox"/>	06:00	1	10	1.6350	6	3.67,3.67	6.00	1'686.00	1'680.00	642.25

Fig. 8.2: Semi-Continuous process schedule compared to continuous and batch process scheduling.

ically displays the semi-continuous schedule data, this allows the user to double-check the data entered. Each process in the overall Gantt chart can be individually selected and this will change what is displayed in the weekly Gantt chart.

Scheduling Intervals:

The scheduling of semi-continuous processes is convenient as it models the time schedule of processes often seen in small and medium sized enterprises (SMEs). As with continuous processes, the start and end of operation of the process itself forms a scheduling interval (SI). A continuous process exists over the entire duration of the SI, so the operating case (OC) duration is the same as the SI. However, for semi-continuous processes a repeated period of operation during the week forms based on the duration of the semi-continuous process, either on a daily time base or a weekly base. This repeatable period over the course of a single week will repeat a certain number of times throughout the year depending on the scheduling of the process. The PinCH software accounts automatically for this smaller duration by calculating the actual operating time of the process and then using this time period in the calculation of operating costs.

The complexity of the OC structure increases, however, when a semi-continuous process overlaps with other processes. As a result, within the SI not one OC, but several OCs are present (see Fig. 8.3).

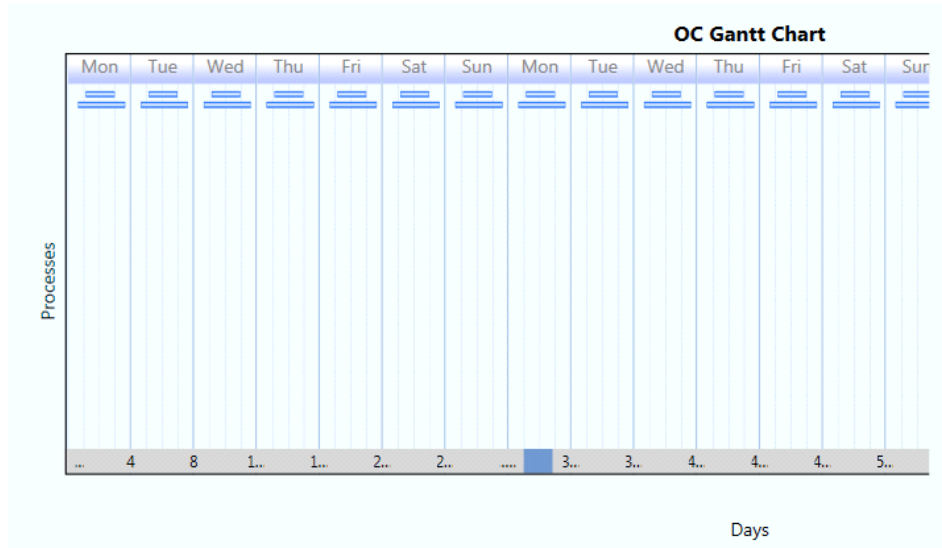

Fig. 8.3: OC Gantt chart showing multiple OCs formed by the overlap of two semi-continuous processes.

8.2.3 Multiple Operating Cases Groups

As reviewed in section 3.3.5 it is possible to configure multiple operating cases consisting of the same streams, but with different states (e.g. summer/winter). In order to use these streams at different states and therefore, have a shared equipment, a Multiple Operating Cases (MOC) Group has to be used. This special type of process grouping allows for proper calculation of area targets when using the combined supertargeting tool. An example of the scheduling of an MOC group is shown in figure 8.4. In addition, the group is needed when using the same streams in multiple processes that do not overlap in time yet need to be assigned to the same Target Group. Please see section 6.3 on how to add a MOC Group.

+/-	Process	Timebase	Mo	Tu	We	Th	Fr	Sa	Su	Daytime Start [hh:mm]	CW Start [week]	# Weeks	Duration [h]	Prod. Campaign Start [h]	Prod. Campaign End [h]	Gross Op. Time [h/a]	Net Op. Time [h/a]
	Distillation	Cont. Year	<input checked="" type="radio"/>	<input type="radio"/>	<input type="radio"/>	<input type="radio"/>	<input type="radio"/>	<input type="radio"/>	<input type="radio"/>	00:00	1	-	6'000.00	0.00	6'000.00	6'000.00	6'000.00
	Spezialchemikalien	Cont. Year	<input checked="" type="radio"/>	<input type="radio"/>	<input type="radio"/>	<input type="radio"/>	<input type="radio"/>	<input type="radio"/>	<input type="radio"/>	00:00	1	-	7'000.00	0.00	7'000.00	7'000.00	7'000.00
	Dest_TSA	Cont. Year	<input checked="" type="radio"/>	<input type="radio"/>	<input type="radio"/>	<input type="radio"/>	<input type="radio"/>	<input type="radio"/>	<input type="radio"/>	00:00	1	-	6'000.00	0.00	6'000.00	6'000.00	6'000.00
	MOC Spez TSA		<input checked="" type="radio"/>	<input type="radio"/>	<input type="radio"/>	<input type="radio"/>	<input type="radio"/>	<input type="radio"/>	<input type="radio"/>								
	Spez_TSA OC1	Cont. Year	<input checked="" type="radio"/>	<input type="radio"/>	<input type="radio"/>	<input type="radio"/>	<input type="radio"/>	<input type="radio"/>	<input type="radio"/>	00:00	1	-	6'000.00	0.00	6'000.00	6'000.00	6'000.00
	Spez_TSA OC2	Cont. Year	<input checked="" type="radio"/>	<input type="radio"/>	<input type="radio"/>	<input type="radio"/>	<input type="radio"/>	<input type="radio"/>	<input type="radio"/>	00:00	37	-	1'000.00	6'048.00	7'048.00	1'000.00	1'000.00

Fig. 8.4: MOC Group Scheduling example

8.3 How to Create and Prepare a Target Group

To create a new Target Group, the commands on the Target Explorer tree must be used. The target explorer encapsulates all the necessary functionality used in configuring and calculating the dynamic information used in analysis. The first step is to create a grouping of processes that are to be analyzed within a Target Group. More than one process can be selected to create the multiple operating cases as discussed in section 8.2.3.

Note: Duplicate streams are not allowed in the different processes that are added to the same targeting group.

To create a Target Group:

1. Select and highlight the *BaseCase* node in the *Target Explorer*
2. Right click on the *BaseCase* node to view the context menu and select *Add Target Group*
3. Select the newly created target group listed under the *BaseCase* node and press *F2*
4. Rename the node as required

8.4 Simplify Energy Targets - Energy Target Analysis

As noted in the introduction, industrial processes often consist of more than one logical grouping of process streams separated by the constraint of physical location. Energy Target Analysis (ETA) provides a powerful set of tools to analyze the entire site for the greatest opportunities for heat integration. It is best suited for overlapping continuous and semi-continuous processes in order to identify which combinations of processes and resulting operating cases can provide the greatest opportunity for heat recovery.

The creation of a new Simplified Targeting-Group allows the user to pick and choose and experiment with the processes to see which combination offers the most benefit, from an energy perspective, using process integration. As discussed in section 8.2.2, the overall Gantt chart is divided into scheduling intervals (SI) created by the starting and ending of the individual processes.

If semi-continuous processes exist, then multiple operating cases will exist in each SI. The OC Data grid and the OC Gantt Chart show the complete breakdown for each SI according to these composite operating cases. Figure 8.5 shows the ETA visualizer for two overlapping semi-continuous processes and the resulting OCs within the SI.



Fig. 8.5: Energy Target Analysis (ETA) results visualizer

The ETA provides the flexibility to analyze an entire site to find the best heat integration potential between different overlapping processes. Several steps are required to configure the ETA for the analysis.

How to Create a Simplified ETA Target Group:

1. Select and highlight the *Energy Target Analysis* node in the *Target Explorer* once the associated Target Group has been configured with the required processes
2. Right click on the *Energy Target Analysis* node to view the context menu and select *Open Energy Target Analysis*
3. As a first step, select the desired processes to be analyzed together by selecting them in the *Processes & Groups* box to ensure they show on the Overall Gantt chart (see Fig. 8.6)

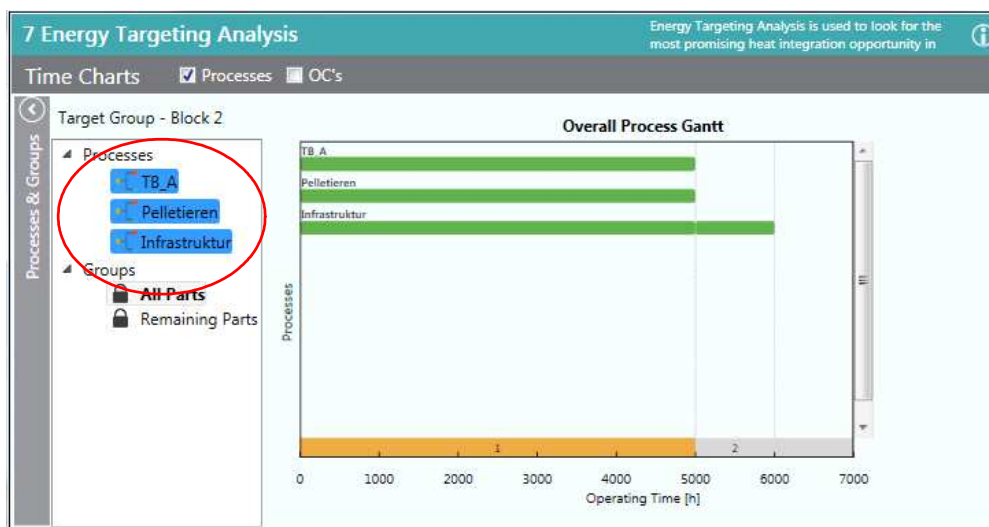

Fig. 8.6: ETA Configuration Step 1 - select the desired processes to be analyzed together to show them in the Overall Process Gantt chart

1. As a second step, create an ETA simplified target group by first selecting and highlighting the *Groups* node
2. Right click on the *Groups* node and select *Add Simplified Targeting-Group* (see Fig. 8.7)
3. Select the newly created simplified target group listed under the *Groups* node and press *F2*

4. Rename the node as required

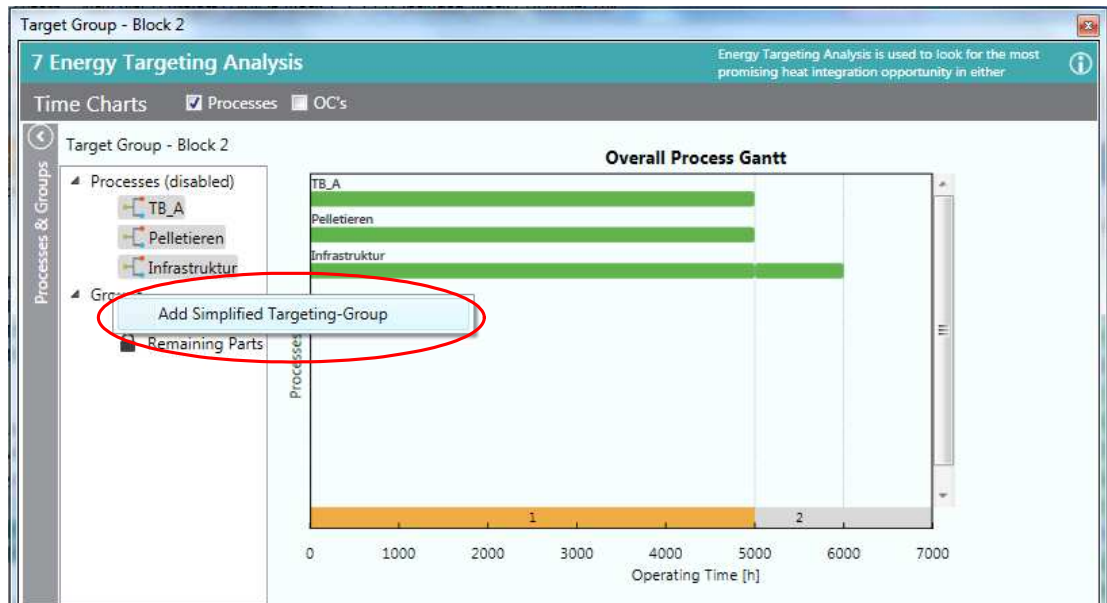

Fig. 8.7: ETA Configuration Step 2 - create a simplified targeting group to allow selection of parts of processes in order to determine best integration potentials

1. As a third step, use the left mouse button to select the processes to be analyzed together directly on the *Overall Process Gantt* chart
2. Select the parts of the processes in the SIs to be included or not included in the analysis as shown in figure 8.8

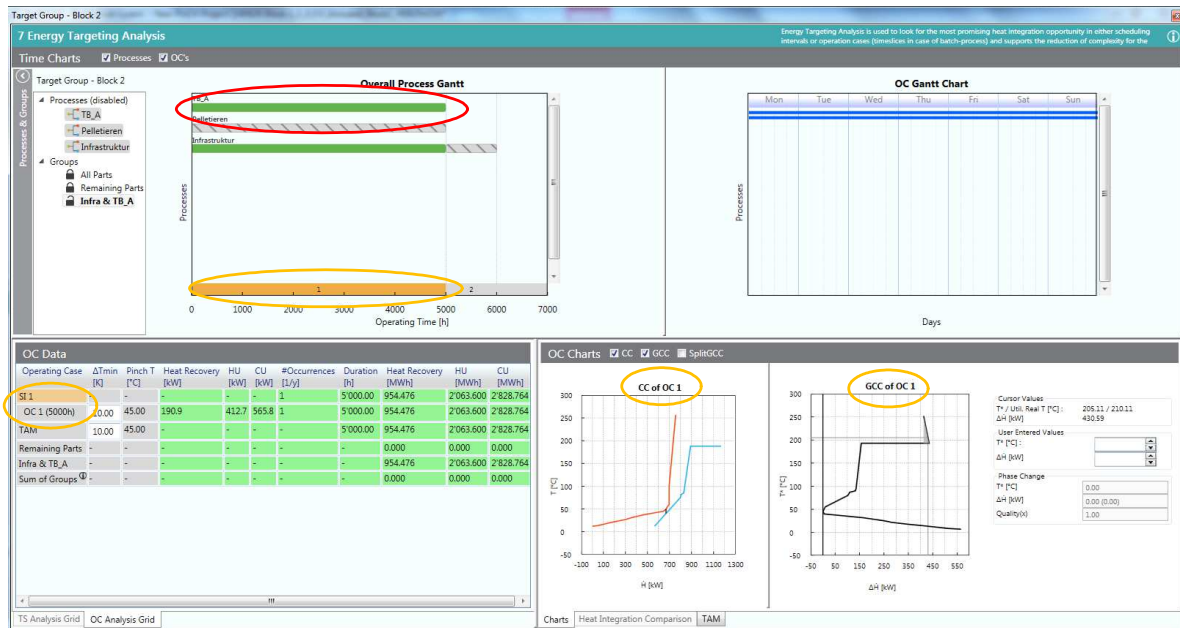

Fig. 8.8: ETA Configuration Step 3 - select processes or part of process in a SI and analyze the heat integration potential using the OC Data grid or charts

The heat integration potential of each selected scheduling interval (SI) can be easily assessed by selecting the number in the footer of the Overall Process Gantt chart (see yellow circles in figure 8.8). The associated OC target results for a given ΔT_{min} are shown in the lower left section of the visualizer as shown in 8.8 on the OC Data grid. There is no cost information shown as the ETA functionality is designed to solely focus on heat integration and best potentials. Therefore, the ΔT_{min} will have to be set based on experience and then optimized later when creating an actual Target Result at a later step.

How to Analyze A Simplified Target Group - Energy & Cost Targets:

1. Once an ETA simplified target group has been analyzed for energy potential select the small icon lock to the left of the node to add the ETA group to the Target Explorer
2. Select and highlight the *Energy Target Analysis* node in the *Target Explorer*
3. Either double click the *Energy Target Analysis* node or click the arrow on the node to open the listing of locked ETA simplified target groups
4. Right click on the ETA simplified target group of interest and select context menu *Create Target Result from Group* to add a Target Result node to the Target Group (the name of the ETA simplified group will be appended to the name of the Target Result)
5. Right click on the created Target Result node and select *Open Target Result with Separate Design* or *Open Target Result with Combined SuperTargeting (Advanced)* if multiple OCs exist and you wish to do MOC supertargeting

Note: The lock function will not work if parts of processes already exist in a Simplified Target Group that has been already analyzed for Energy and Costs (i.e. no duplication of a stream in Targeting is allowed!).

The results available in the ETA include the OC Data grid for displaying the energy targets (kW and MWh, see Figure 8.5 and 8.8)) and the CC/GCC/Split GCC charts (see Figure 8.9) for a selected SI. An OC Gantt chart is also displayed which shows the weekly production campaign schedule for each process that exists in the select SI. This chart is very useful to see how the particular OCs form based on the schedule.

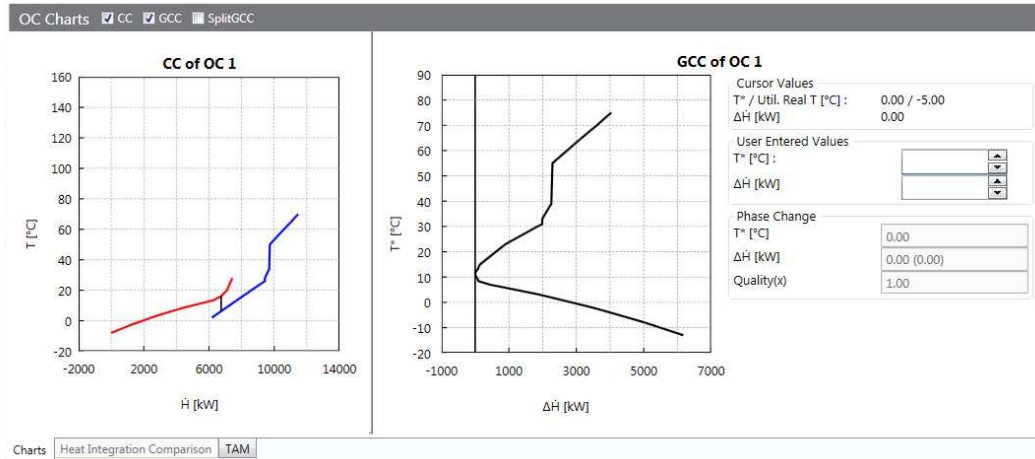

Fig. 8.9: ETA Charts for each operating case

In addition, the Time Average Model (TAM) results for the selected SI is also available in the OC Data grid and as separate OC Charts. The weighting of the stream data is based on the net operating time as well as on the scheduling information and is done automatically for the selected SI. The result provides an indication of the suitability for storage between adjacent OCs.

8.5 How to Create and Analyze Target Results

A powerful feature of the Target Explorer is the flexibility it gives in comparing different Target Results. As shown in figure 8.10, not only are the energy targets displayed but the number of units targets, cost targets and area targets are shown. These results are calculated based on either a simple cost curve analysis or the more advanced combined supertargeting cost optimizer (for MOC processes) to ensure the best economic efficiency.

For any particular target group, multiple target results can be created and then automatically saved under the target group tree node. A selection of different scenarios can be saved directly and used easily for comparing the results of each scenario in order to find the best heat integration option.

Creating Multiple Target Results:

1. Create a Target Result as described for single continuous process in section 7.3



Fig. 8.10: MOC Combined Supertargeting Target Result showing the results for Conventional Design together with the summaries of the Separate Design and the Resequence Design types

2. Right click on the same *Results* node and select *Calculate Target Result with...* and then *Separate Design* to create a second target result. A new Target Result visualizer component will be added to a dockable window and positioned in the center of the workbench
3. All the nodes can be renamed after pressing F2
4. Change the ΔT_{min} in the new Target result to a different value
5. Repeat for required number of different ΔT_{min} values

Note: Additional target results can be created when an ECU (see section 11.4 Integrate Energy Conversion Units), soft streams or multiple utilities (see section 4) are added. The workbench is composed of dockable windows that can be moved and repositioned throughout the workbench. This allows for an easy comparison of the results or the data, which has been entered (see Chap. 7.4 Fig. 7.4).

The results derived from a Target Result can be analyzed using either the OC Charts in the middle section of the Target Result dockable window or the

OC Data grid shown at the bottom of the window (see Fig. 8.10). The charts include the Composite Curve (CC), Grand Composite Curve (GCC), Balanced Composite Curve (BCC), Balanced Grand Composite Curve (BGCC), Cost Curves and the Split Grand Composite Curve (Split GCC). The cost curves include a breakdown of the annual investment cost curve into the investment cost for internal process-process heat exchangers, CU-process heat exchangers and the HU-process heat exchangers. The targeting values listed in the OC Data grid are summarized in the following table 9.2:

Tab. 8.2: Results Panel Targeting Values Table

Results Panel Values	Description	Units
Operating Case/ Time Slice	The time slice in which specific streams exist at the same time	
Time Schedule	The absolute start and end time of an operating case or time slice	hour
ΔT_{min}	The vertical distance between the hot and the cold composite curve at the closest point	K
Pinch T	The pinch temperature represented by the closest approach of the hot and the cold composite curve	°C
Heat Recovery	The amount of heat exchange between process-process or internal utility-process streams	kW
Hot Util	The minimum amount of hot utility needed for heating based on the specified ΔT_{min} for the given composite curves	kW
Cold Util	The minimum amount of cold utility needed for cooling based on the specified ΔT_{min} for the given composite curves	kW
Area	The amount of heat exchanger area calculated based on the given composite curves and ΔT_{min} assuming vertical heat transfer for the spaghetti network [12]	m ²
Nunits	The total number of units calculated based on the given composite curve and ΔT_{min}	[-]
Yearly Cost	The total annual cost for the given composite curve and ΔT_{min}	CHF/ year
Operating Cost	The total annual operating cost for the given composite curve and ΔT_{min} (Utility, ECU and Site Electricity, maintenance and personnel)	CHF/ year
Total Inv. Cost	The total cost of the required heat exchanger area plus any remaining ECU investment cost (e.g. compressor cost)	CHF
Heat Recovery Inv. Cost	The heat exchanger investment cost associated with process-process or internal utility-process streams heat exchange	CHF

Continuation of table:

Results Panel Values	Description	Units
HU Inv. cost	The heat exchanger investment cost only associated with the default hot utility-process heat exchange	CHF
CU Inv. cost	The heat exchanger investment cost only associated with the default cold utility-process heat exchange	CHF
ECUs Remaining Inv. Cost	Inv cost for ECUs not including the heat exchanger investment costs for ECUs. (Note: ECU heat exchanger investment costs are included directly in the Energy Recovery Investment cost calculation)	CHF

Note: Only heat flow values are shown in the Target Result. To see the energy values the Energy Target Analysis feature will have to be used.

Adding and Sizing Internal Utilities:

The default utilities (both hot and cold) must always be added to a Target Group. This ensures that the energy balance for each associated Target Result can be completed and the proper cost can be calculated. In order to include multiple “internal” utilities, additional hot and cold utilities can be added to the Utility Stream Table and assigned to the Target Group along with the default hot and cold utilities. These internal utilities can then be sized. The heat flow of each internal utility must be specifically set and can be typically derived from the GCC.

As by single continuous processes, internal utilities can be added and used to optimize the energy supply. When internal utilities are added to a Target Group two rows are shown in the OC Data - one for the regular composite curve (CC) using only the default utilities and one for the balanced composite curve which includes the internal utilities.

How to Size Internal Utilities:

1. Create a Target Result as described above.
2. Add an additional utility stream to the Utility Stream Table.
3. Assign the newly added utility stream to the Target Group.

4. Add a new Separate Design Target Result.
5. Right click on the CC row within the OC Data or TS data grid and select **Size Utilities**. Optionally, the properties window tab can be first selected and then the CC or BCC row selected to display the Cold Utility/Hot Utility Sizing text entry boxes.
6. Enter a heat flow value for the internal utility in the associated text entry box. The balanced composite curve will update accordingly (the composite curve only contains the default utilities so it will not change).

The calculation of Target Results for energy and cost optimization involving MOC processes is more complex than by single continuous processes. In particular there are more operating cases that exist using many of the same streams or different operating states of the same streams (i.e. shared) over the course of an entire year. The question arises in how to minimize total cost of the underlying heat exchanger network (HEN) to ensure the reuse of heat exchanger area is maximized leading to lower investment cost. As a result, PinCH provides three different calculation methods to provide target results that can be compared. When all three types are calculated together in the same Target Result this is called Combined Supertargeting.

8.5.1 Separate Design Target Results

The separate design calculation is based on the assumption of complete separation of each OC from all other OCs. Simply put each OC is assumed to have its own heat exchanger network and each would have to be built separately. This target represents the most expensive option and provides an upper bound on the total investment cost. Its calculation is exactly as described in the section for Single Continuous processes but applied to each OC separately. The cost curve is simply used to optimize each ΔT_{min} separately with no consideration for reusing heat exchanger area.

8.5.2 Conventional and Resequence Design Target Results

Conventional and resequence design heat exchanger network design types calculate new targets that account for the time dependent behaviour involved in multiple operating cases or batch processes. In such processes direct heat transfer can be optimized to account for the overlapping common area of heat

exchangers that transfer heat between the same streams but at different states and different time periods. Conventional and resequence design types provide additional flexibility in HEN design and can be incorporated into early design stage. Both design types aid in ensuring the maximum amount of common heat exchange area is used to reduce investment cost. The optimization is based on relatively straightforward linear program formulations with the goal to determine a minimum capital cost HEN that is valid in all MOCs or time slices at the Targeting stage. Please see Appendix A.9 for more information.

How to Calculate a Combined Supertargeting Result:

1. Create a Target Result as described for a single continuous process in section 7.3, but select processes that create multiple operating cases
2. Right click on the same *Results* node and select *Calculate Target Result with...* and then *Combined SuperTargeting (Advanced)* to create a second target result. A new Target Result visualizer component will be added to a dockable window and positioned in the center of the workbench
3. All the nodes can be renamed after pressing F2
4. Select the radio button on the header of the OC Data grid to switch the results between Separate, Conventional and Resequence design and compare the values for the same set of ΔT_{min} values automatically created based on the Separate design cost curves (see figure 8.10)
5. Select the Conventional design radio button
6. Press the *Optimize* Button to calculate a new set of ΔT_{min} values based on the Conventional design constraint
7. Repeat for the Resequence design constraint
8. Select the lock icon next to the Separate, Conventional and Resequence summary row to unlock the value displayed (All unlocked results will update automatically based on select design type and its associated ΔT_{min} values)

Both conventional and resequence design types calculate the total heat exchanger network (HEN) area and the number of units as there is in principle only one HEN. Therefore, OC specific areas and number of units are not

calculated. Only the separate design can calculate individual values for each OC as, per definition, each OC is separate.

As discussed in section 8.2.2 a multiple operating case analysis can consist of many small operating cases created by the overlap of semi-continuous processes. Due to non-synchronization of the different semi-continuous processes, composite OCs can be created that contain the same set of streams but differ slightly in their duration. Nevertheless, PinCH automatically accounts for these slight differences and calculates a total Target Result for each distinct OC and adjusts the total net operation time accordingly. As a result, the composite OCs are not shown on the OC Data grid, only the distinct OCs.

Note: MOC/Batch Supertargeting are calculated only with default hot and cold utility.

8.6 Multiple Operating Cases – Analysis Support Tools

Several tools presently exist to support the analysis of multiple operating cases Target Results. First is the use of Perspectives to allow the user to quickly focus on the important information during the analysis of a Target Result. As seen in figure 8.10 a combobox is displayed in the header of the dockable window with the following options:

- Orientation
- Optimization
- Analyzing

The *Orientation* perspective shows the following charts:

- Overall Gantt Chart
- OC Gantt Chart

The *Optimization* perspective is the most often used as it shows the following charts:

- Composite Curve CC
- Grand Composite Curve GCC
- Balanced Composite Curve CC
- Balanced Grand Composite Curve GCC
- Cost Curve CC
- Split Grand Composite Curve

Finally, the *Analyze* perspective shows the OC Data grid with the targeting results of each OC.

A second tool is the *OC Selector* that is per default shown on the right side of the Target Result visualizer (see figure 8.10). The selector provides the ability to display or not display any particular OC in the OC Charts shown in the Optimization perspective. This tool is very useful to help focus on the critical OCs to be analyzed.

The third is the Split Grand Composite Curve (Fig. 9.4). This graphic allows the display of two separate grand composite curves in operating cases (OCs) from the same or or even other Target Groups and Target Results. This functionality provides the ability to investigate the possibility of integrating the two processes using for example intermediate loops. In addition, it can be used to assess indirect heat integration between time slices of a single batch process.

Note: The second selected grand composite curve is mirrored relative to the other grand composite curve.

The split GCC can be accessed by the OC Charts selector in the header of the OC Charts group box. All distinct OCs in any other Target Group and Target Result can be selected as the extracted process giving total flexibility in the desired configuration.

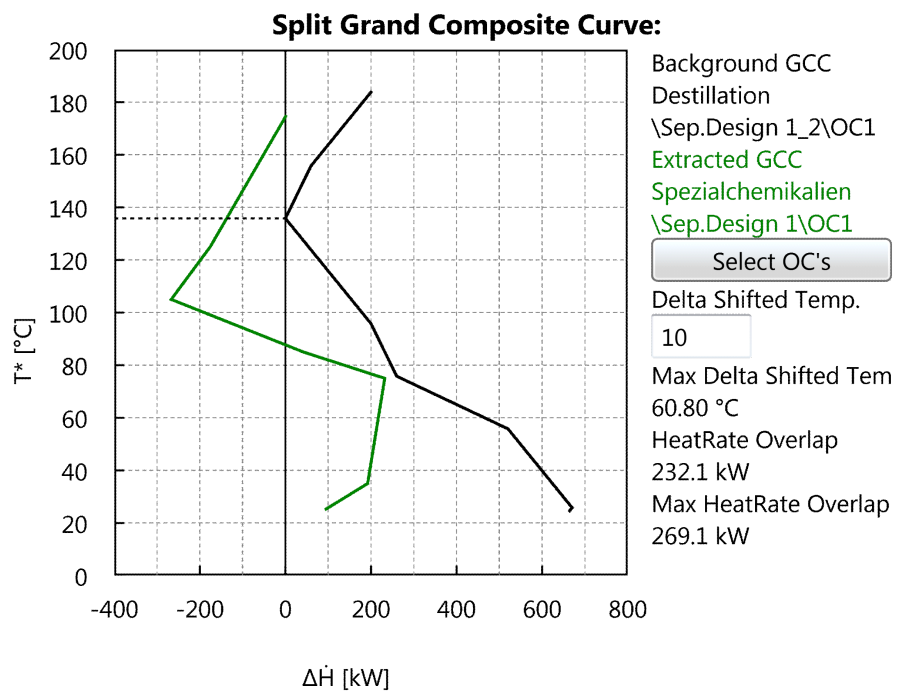

Fig. 8.11: Split Grand Composite Curve

Chapter 9

Analyzing Single Product Batch Processes - Direct Heat Recovery

9.1 Introduction

Batch processes are prevalent in industry and account for a major portion of all industrial processes. They are typically used in the following circumstances:

- when there are very slow conversions (long residence times)
- when only a small quantity of a product is produced but with a high profit margin
- when a flexible manufacturing process and/or change to the product is important (multi-product plants or multi-purpose equipment)
- when a continuous process is too technically difficult to realize

A batch consists of a single process with differing stream existence times. This results in multiple time slices, each of which has its own composite curve. Analysis becomes complex as opportunities for energy recovery become bounded due to time constraints and it can not be assumed that each stream can potentially exchange energy with all other streams of opposite hot or cold designation at all times. Nevertheless, increasing direct heat transfer in a batch process is an important economic and energetic consideration.

9.2 How to Schedule a Batch Process

Single product batch processes are a common form of production used in industry to produce special products that are constrained by high quality standards, low quantity, flexibility requirements or reaction times. As a result, the schedule of a batch process is characterized by the time dependence of the streams. The time period of existence for each stream can be different from that of other streams. The structure of the time schedule of each stream can be clearly seen in a Gantt chart. PinCH supports the scheduling of single product batch streams through the Process Stream Table and Operating Cases Schedule.

PinCH provides real world scheduling capability to model most of the process types encountered in industry. In section 3.3.6 it is shown how a single product batch can be scheduled.

9.2.1 Scheduling Stream Existence Times (Process Stream Table)

The use and defining of streams in the Process Stream Table is given in section 4.3. The key parameters to include for a batch stream are the t_{Start} and t_{stop} times. These parameters define the absolute existence time within the single batch itself. These parameters ensure that the relative timing of the streams and the associated heating or cooling demands are maintained in comparison to the other streams. This model assumes the existence times are fixed and repeated in a cyclical manner. A time slice model (TSM) can then be easily created and analyzed.

9.2.2 Scheduling the Single Batch Process (Operating Cases Schedules)

The scheduling of a single product batch process is characterized by two main forms:

- Scheduling of the single product batch
- Scheduling of a single product batch that overlaps with itself

The first form is the standard configuration of a batch process as it must be repeated a certain number of times over the duration of, for example, one year. This is done easily by setting directly the number of weeks (# Weeks) and the number of batches (# Batches) and indirectly by setting in which calendar week the batch process starts (CW Start) as shown in Fig. 9.1.

Continuous Processes																	
+/-	Process	Timebase	Mo	Tu	We	Th	Fr	Sa	Su	Daytime Start [hh:mm]	CW Start [week]	# Weeks	Duration [h]	Prod. Campaign Start [h]	Prod. Campaign End [h]	Gross Op. Time [h/a]	Net Op. Time [h/a]
	Continuous Process	Cont. Year	<input type="radio"/>	<input type="radio"/>	<input type="radio"/>	<input type="radio"/>	<input type="radio"/>	<input type="radio"/>	<input type="radio"/>	06:00	1	-	4'000.00	6.00	4'006.00	4'000.00	4'000.00
	Semi-Continuous Process	Cont. Daily	<input checked="" type="checkbox"/>	<input checked="" type="checkbox"/>	<input checked="" type="checkbox"/>	<input checked="" type="checkbox"/>	<input type="checkbox"/>	<input type="checkbox"/>	<input type="checkbox"/>	04:00	1	30	14.00	4.00	5'044.00	5'040.00	5'000.00

Batch Processes																			
+/-	Process	Timebase	Mo	Tu	We	Th	Fr	Sa	Su	Daytime Start [hh:mm]	CW Start [week]	# Weeks	BCD [h]	# Batches	BPD,BSD [h]	Prod. Campaign Start [h]	Prod. Campaign End [h]	Gross Op. Time [h/a]	Net Op. Time [h/a]
	Batch Process	Batch Daily	<input checked="" type="checkbox"/>	<input checked="" type="checkbox"/>	<input checked="" type="checkbox"/>	<input checked="" type="checkbox"/>	<input checked="" type="checkbox"/>	<input type="checkbox"/>	<input type="checkbox"/>	06:00	1	10	1.8350	6	3,67,3.67	6.00	1'686.00	1'680.00	642.25

Fig. 9.1: Semi-Continuous process schedule compared to continuous and batch process scheduling.

The second form is characterized by scheduling a single batch process to overlap with itself. This is often the case in industry as production must be maximized and idle equipment from a previous batch can and should be put into operation by simply starting a new batch before the previous batch is complete. In the PinCH software this can be done by setting the Batch Cycle Duration (BCD) to be less than the Batch Process Duration (BPD) to indicate that the batch starts sooner. Both of these parameters are available in the operating case schedule for batch processes (see Fig. 9.1 and Table 9.1)

Tab. 9.1: Continuous Process, Operating Cases, Scheduling and Data Grid Values Table

Scheduling Grid Values	Description	Units
Process	The name of each process to be scheduled as defined in the project explorer.	
Timebase	The time frame for which a batch process operates (Batch Daily, Batch Weekly or Batch Yearly)	
Mo	Monday - Selected day of the week on which the first batch process begins.	
Tu	Tuesday - Selected day of the week on which the first batch process begins.	
We	Wednesday - Selected day of the week on which the first batch process begins.	
Th	Thursday - Selected day of the week on which the first batch process begins.	
Fr	Friday - Selected day of the week on which the first batch process begins.	
Sa	Saturday - Selected day of the week on which the first batch process begins.	
Su	Sunday - Selected day of the week on which the first batch process begins.	
Daytime Start hh:mm	The actual start time in the selected week given in hours and minutes of the day.	hh:mm
CW Start	The calendar week of the year in which the process starts.	
No. Weeks	The number of weeks a batch process is in operation.	
BCD	Batch Cycle Duration – Time of duration between the start of one batch and the beginning of the next batch.	h
No. Batches	Number of batches occurring within the chosen time base (daily weekly or yearly)	

Continuation of table:

Scheduling Grid Values	Description	Units
BPD,BSD	Batch Cycle Duration – Time duration of equipment repeat operation period (EROP), which includes pre and post processing times. Batch Stream Duration – Time duration of (EROP) considering only the stream start and stop times	h
Prod. Campaign Start	The calculated absolute start time in the year for the selected process.	h
Prod. Campaign End	The calculated absolute end time in the year for the selected process.	h
Gross Op. Time	The calculated time difference between the absolute start and end time over the year.	h/a
Net Op. Time	The actual operation time of the selected process over the year.	h/a

Additional information on the scheduling of overlapping batches can be found in Appendix A.10.

9.3 How to Create and Prepare a Target Group

To create a new Target Group commands on the Target Explorer tree must be used. The target explorer encapsulates all the necessary functionality used in configuring and calculating the dynamic information used in analysis. The first step is to create a grouping of processes that are to be analyzed within a Target Group. However, for the specific energy and cost target analysis (re. Target Result section) of single batch process and its associated time slice (TS) model it is required that only the batch process be added to the Target Group. No support is given for overlapping of different batch processes as this is still a subject of fundamental research. However, the Energy Targeting Analysis functionality (section 9.4) can be used to analyze the Time Average Model (TAM) of the overlapping processes.

Note: Duplicate streams are not allowed in different processes that are added to the same targeting group.

To create a Target Group:

1. Select and highlight the *BaseCase* node in the *Target Explorer*
2. Right click on the *BaseCase* node to view the context menu and select *Add Target Group*
3. Select the newly created target group listed under the *BaseCase* node and press *F2*
4. Rename the node as required

9.4 Simplify Energy Targets - Energy Target Analysis

As noted in the introduction, industrial processes often consist of single product batch processes for the production of special products. Often the heat integration of such processes is ignored as the focus is on low-quantity high-quality specialty products. Nevertheless, there is great potential for improving the energy efficiency of such processes given this traditional lack of interest in the energy efficiency.

The Energy Target Analysis (ETA) provides a powerful set of tools to analyze the batch process Gantt or time slice model (TSM) and look for the best opportunities for direct heat transfer within the TSs. Simplification of the TSM is also possible in order to focus in on the best possible direct heat transfer possibilities. In addition, support is given through the Time Average Model (TAM), Split GCC and the GCC based ISSP to assess the potential for indirect heat transfer using heat storages. Figure 9.2 shows the entire ETA visualizer with the different analysis objects.



Fig. 9.2: ETA Single Product Batch visualizer showing the different analysis objects - OC Gantt Chart, Equipment Repeated Operation Period Gantt, TS Data grid and the TS Charts. Not displayed or hidden are the TAM charts, Heat Integration Comparison Charts, the split GCC Chart and the GCC based ISSP Chart.

9.5 How to Create and Analyze Target Results

PinCH provides the ability to easily view and compare the results in each time slice, which helps in the search for new opportunities for improved process integration.

To Create a Target Result for a Batch:

1. Create a **Target Group**
2. Select and highlight the **Target Group node** in the Target Explorer
3. Right click on the Target Group node to view the context menu and select **Reassign Operating Cases Schedule** and re-assign a schedule as needed.
4. Right click on the Target Group node to view the context menu and select **Reassign Economic Data**; re-assign the economic data as needed.

5. Right click on the **Processes node** and select a batch process to be used in the analysis. (Ensure that t_{start} and t_{stop} have been included for each stream in the Process Stream Table beforehand as defined in section 4.3).
6. Right click on the **Utilities node** and select a default hot and a default cold utility (see note given below)
7. Right click on the **Results node** and select **Separate Design Tool** to create the target result
8. All the nodes can be renamed after pressing F2

In this case, there are two tools available for analysis - **Separate Design Tool** and **Combined Supertargeting Tool**. The separate design tool analyzes the absolute stream existence times and decomposes the data into separate time slices or operating cases. Each slice is independent of the other and can be analyzed on its own. The combined supertargeting tool uses the conventional and resequence design types to calculate the optimum HEX area when common or reused area of HEX on the same streams in different TSs is accounted for. Please see Appendix A.9 and section 9.5.2 for more information.

Note: It is critical to have created at least one hot and one cold stream in the Utility Stream Table. Please be certain to ensure the respective temperature ranges of these utilities provide enough driving force for the given process streams. These two utilities will need to be assigned as the default hot and cold utility in order to allow the internal energy balance to be closed. This is particularly important in the case of adding multiple utilities used in optimizing such systems.

After completing the above steps a window will be created and anchored on the workbench with a tab. This window encapsulates the entire targeting result for the selected tool (in this case either the Separate Design Tool or Time Average Model). Fig. 9.3 shows the result for a Separate Design Tool target result for a single batch process.

By selecting check boxes on the filter panel, the composite curve, grand composite curve, balance composite curve, balanced grand composite curve, cost curve as well as the gantt chart can be selected for viewing. Each will be displayed automatically in the upper portion of the dockable window while the results for a given process ΔT_{min} (entered on the Main Control Panel) will be shown on the Results Panel data grid at the bottom of the window.

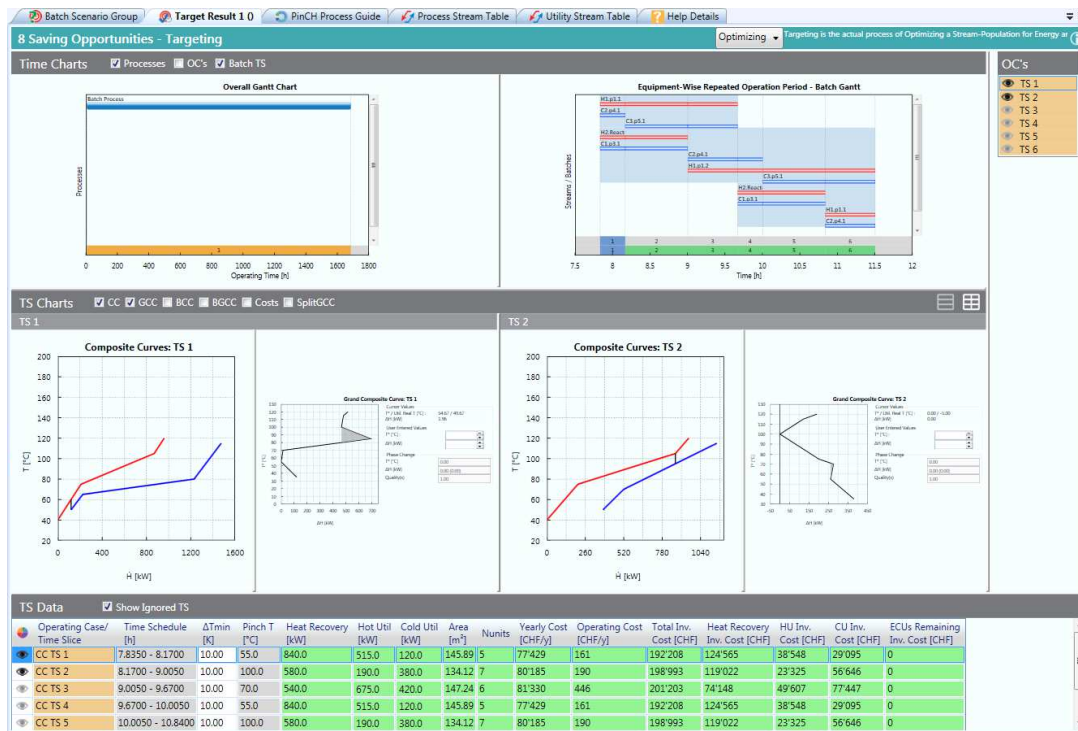

Fig. 9.3: Batch Process Separate Design Tool Target Result

The specific results for each time slice can be viewed on the Results Panel data grid. Both the results for the composite curve (only includes the default hot and cold utility) and the balanced composite curve (includes the default hot and cold utility as well as the additional internal sized utilities) are shown. Any multiple operating cases or time slices will also be listed in the data grids each row representing the targeting result for the particular slice. Table 9.2 provides descriptions of the different columns that appear in the Results Panel.

Tab. 9.2: Results Panel Targeting Values Table

Results Panel Values	Description	Units
Operating Case/ Time Slice	The time slice in which specific streams exist at the same time	
Time Schedule	The absolute start and end time of an operating case or time slice	hour
ΔT_{min}	The vertical distance between the hot and the cold composite curve at the closest point	K
Pinch T	The pinch temperature represented by the closest approach of the hot and the cold composite curve	°C
Heat Recovery	The amount of heat exchange between process-process or internal utility-process streams	kW
Hot Util	The minimum amount of hot utility needed for heating based on the specified ΔT_{min} for the given composite curves	kW
Cold Util	The minimum amount of cold utility needed for cooling based on the specified ΔT_{min} for the given composite curves	kW
Area	The amount of heat exchanger area calculated based on the given composite curves and ΔT_{min} assuming vertical heat transfer for the spaghetti network [12]	m ²
Nunits	The total number of units calculated based on the given composite curve and ΔT_{min}	[-]
Yearly Cost	The total annual cost for the given composite curve and ΔT_{min}	CHF/ year
Operating Cost	The total annual operating cost for the given composite curve and ΔT_{min} (Utility, ECU and Site Electricity, maintenance and personnel)	CHF/ year
Total Inv. Cost	The total cost of the required heat exchanger area plus any remaining ECU investment cost (e.g. compressor cost)	CHF
Heat Recovery Inv. Cost	The heat exchanger investment cost associated with process-process or internal utility-process streams heat exchange	CHF

Continuation of table:

Results Panel Values	Description	Units
HU Inv. cost	The heat exchanger investment cost only associated with the default hot utility-process heat exchange	CHF
CU Inv. cost	The heat exchanger investment cost only associated with the default cold utility-process heat exchange	CHF
ECUs Remaining Inv. Cost	Inv cost for ECUs not including the heat exchanger investment costs for ECUs. (Note: ECU heat exchanger investment costs are included directly in the Energy Recovery Investment cost calculation)	CHF

The specific results for each time slice can be viewed on the Results Panel data grid. Both the results for the composite curve (only includes the default hot and cold utility) and the balanced composite curve (includes the default hot and cold utility as well as the additional internal sized utilities) are shown. Any multiple operating cases or time slices will also be listed in the data grids with each row representing the targetting result for that particular slice.

9.5.1 Separate Design Target Results

The separate design calculation is based on the assumption of complete separation of each TS from all other TSs. Simply put each TS is assumed to have its own heat exchanger network and each would have to be built separately. This target represents the most expensive option and provides an upper bound on the total investment cost. Its calculation is exactly as described in the section for Single Continuous processes but applied to each TS separately. The cost curve is simply used to optimize each ΔT_{min} separately with no consideration for reusing heat exchanger area.

9.5.2 Conventional and Resequence Design Target Results

Conventional and resequence design heat exchanger network design types calculate new targets that account for the time dependent behaviour involved in multiple operating cases or batch processes. In such processes direct heat

transfer can be optimized to account for the overlapping common area of heat exchangers that transfer heat between the same streams but at different states and different time periods. Conventional and resequence design types provide additional flexibility in HEN design and can be incorporated into an early design stage. Both design types aid in ensuring the maximum amount of common heat exchange area is used to reduce investment cost. The optimization is based on relatively straightforward linear program formulations with the goal to determine a minimum capital cost HEN that is valid in all MOCs or time slices at the Targeting stage. Please see Appendix A.9 for more information.

How to Calculate a Combined Supertargeting Result:

1. Create a Target Group as described in section 9.3 for a single product batch process
2. Right click on the same *Results* node and select *Calculate Target Result with...* and then *Combined SuperTargeting (Advanced)* to create a second target result. A new Target Result visualizer component will be added to a dockable window and positioned in the center of the workbench
3. All the nodes can be renamed after pressing F2
4. Select the radio button on the header of the TS Data grid to switch the results between Separate, Conventional and Resequence design and compare the values for the same set of ΔT_{min} values automatically created based on the Separate design cost curves (see figure 8.10)
5. Select the Conventional design radio button
6. Press the *Optimize* Button to calculate a new set of ΔT_{min} values based on the Conventional design constraint
7. Repeat for the Resequence design constraint
8. Select the lock icon next to the Separate, Conventional and Resequence summary row to unlock the value displayed (All unlocked results will update automatically based on select design type and its associated ΔT_{min} values)

Both conventional and resequence design types calculate the total heat exchanger network (HEN) area and the number of units as there is in principle

only one HEN. Therefore, TS specific areas and number of units are not calculated. Only the separate design can calculate individual values for each TS as, per definition, each TS is separate.

Note: MOC/Batch Supertargeting are calculated only with default hot and cold utility.

9.6 Single Product Batch Process Analysis Support Tools

Several tools presently exist to support the analysis of time slices (TSs) of a single batch process Target Result. First is the use of Perspectives to allow the user to quickly focus on the important information during the analysis of a Target Result. As seen in figure 8.10 a combobox is displayed in the header of the dockable window itself with the following options:

- Orientation
- Optimization
- Analyzing

The *Orientation* perspective shows the following charts:

- Overall Gantt Chart
- OC Gantt Chart

The *Optimization* perspective is the most often used as it shows the following charts:

- Composite Curve CC
- Grand Composite Curve GCC
- Balanced Composite Curve CC
- Balanced Grand Composite Curve GCC
- Cost Curve CC

- Split Grand Composite Curve

Finally, the *Analyze* perspective shows the TS Data grid with the targeting results of each TS.

A second tool is the *TS Selector* that is per default shown on the right side of the Target Result visualizer (see figure 8.10). The selector provides the ability to display or not display any particular TS in the TS Charts shown in the Optimization perspective. This tool is very useful to help focus on the critical TSs to be analyzed.

Another tool is the Split Grand Composite Curve (Fig. 9.4). This graphic allows the display of two separate grand composite curves from consecutive TSs. This functionality provides the ability to investigate the possibility of integrating the two TSs using for example intermediate loops with heat storage. This helps to assess indirect heat integration between time slices of a single batch process.

Note: The second selected grand composite curve is mirrored relative to the other grand composite curve.

The split GCC can be accessed by the TS Charts selector in the header of the TS Charts group box. All distinct TSs in any other Target Group and Target result can be selected as the extracted process giving total flexibility in the desired configuration.

Note: Please see section 12.6 for information related to exporting area matrices for target results of each time slice.

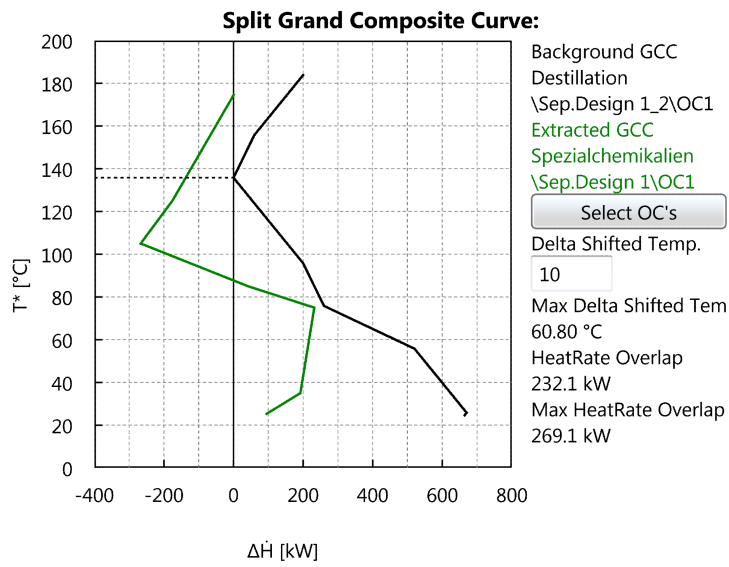

Fig. 9.4: Split Grand Composite Curve

Chapter 10

Analyzing Single Product Batch Processes - Indirect Heat Recovery

10.1 Introduction

Direct heat recovery (HR) by the means of a Heat Exchanger Network (HEN) has been successfully applied to continuous processes, yet has limited potential for the intra- or inter-integration of non-continuous processes. In such processes, direct HR can be applied within time intervals where both hot and cold process streams occur simultaneously, but any variability in the schedule directly affects the achieved HR of a particular HEN design. Therefore, in order to achieve a more flexible and much less schedule sensitive HR process design, a combined Heat Exchanger and Storage Network (HESN) can be used to absorb schedule variation in addition to allowing the heat transfer from earlier time intervals to later ones. Non continuous processes are batch or semi-continuous processes commonly found in the pharmaceutical, food and biochemistry industry at temperature levels low enough to allow cost effective sensible heat thermal energy storage (TES) using water as the storage medium. If the temperature levels are above the applicability level of water, thermal oil is used instead?

Indirect heat recovery is achieved using intermediate loops (IL) and heat storages (HS) (i.e. there is no direct heat transfer between any of the streams involved in the pinch analysis). This allows the full energy content of a stream to be captured and potentially used for heat recovery, regardless of when the stream occurs in time. The graphical method used in the design of TES systems is the Indirect Source and Sink Profile (ISSP) in order to determine

the indirect heat recovery potential of a batch process. This functionality provides a third component as a basis of the PinCH software as shown in Fig. 10.1 in the lower right. More information is given in Appendix A.11 and in references [19 - 21].

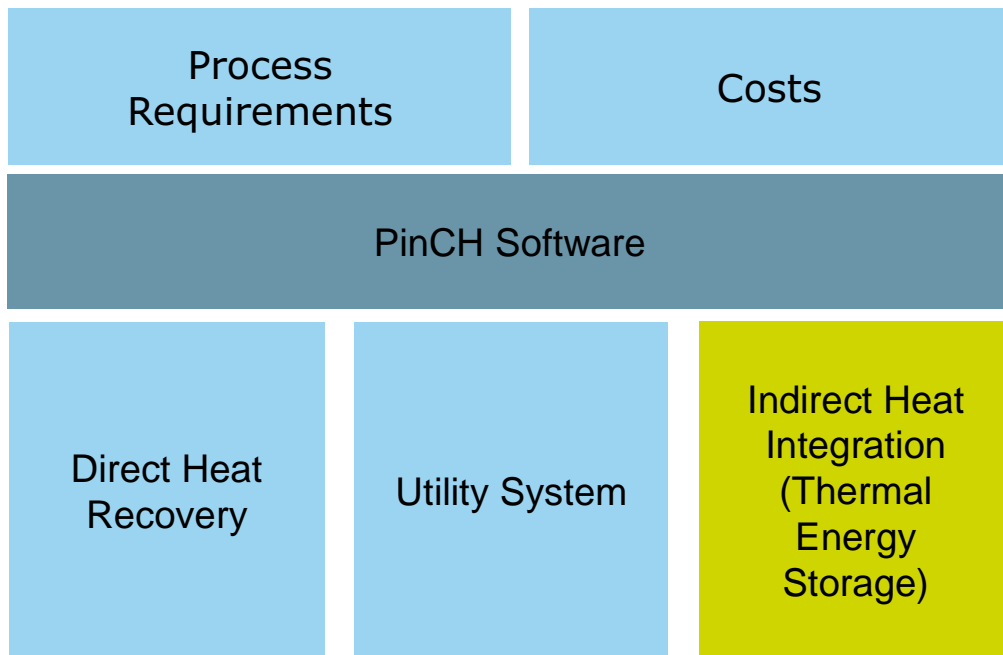

Fig. 10.1: PinCH Software main components highlighting the indirect heat recovery beside the direct heat recovery and utility system components that together form the foundation of the software.

10.2 How to Create and Prepare a Target Group

The calculation of indirect heat recovery using thermal energy storage is based on a single product batch process. For information on how to create a batch process please see section 9.2. In addition, information related to the preparation of a target group using the same batch process is given in section 9.3.

Note: The use of simplified target groups created in the energy target analysis (ETA) as well as softstreams are not presently supported in the creation of indirect heat recovery target results. This means that segments of batch streams cannot be ignored (as is possible in the ETA) resulting in the entire stream always being used!

10.3 How to Create and Analyze Target Results

PinCH provides the ability to easily view and modify the indirect heat recovery results in order to develop a cost effective conceptual design.

To Create an Indirect Heat Recovery Target Result for a Batch:

1. Create a **Target Group**
2. Select and highlight the **Target Group node** in the Target Explorer
3. Right click on the Target Group node to view the context menu and select **Reassign Operating Cases Schedule** and re-assign a schedule as needed.
4. Right click on the Target Group node to view the context menu and select **Reassign Economic Data**; re-assign the economic data as needed.
5. Right click on the **Processes node** and select a batch process to be used in the analysis. (Ensure that t_{start} and t_{stop} have been included for each stream in the Process Stream Table beforehand as defined in section 4.3).
6. Right click on the **Utilities node** and select a default hot and a default cold utility (see note given below)
7. Right click on the **Results node** and select **Indirect Heat Recovery** to create the target result
8. All the nodes can be renamed after pressing F2

After completing the above steps a window will be created and anchored on the workbench with a tab. This window encapsulates the entire targeting result for the indirect heat recovery result. Fig. 10.2 shows an example target result for an indirect heat recovery analysis.

Graphics will be displayed automatically in the upper portion of the dockable window. Specific configuration information or calculated results is shown on the lower part of the dockable window in data table grids. Details of the specific charts and data grid information is presented in the next section 10.3.1. The specific grouping on tabs of graphics and data grid information is shown in section 10.4

Note: It is critical to have created at least one hot and one cold stream in the Utility Stream Table. Please be certain to ensure the respective temperature

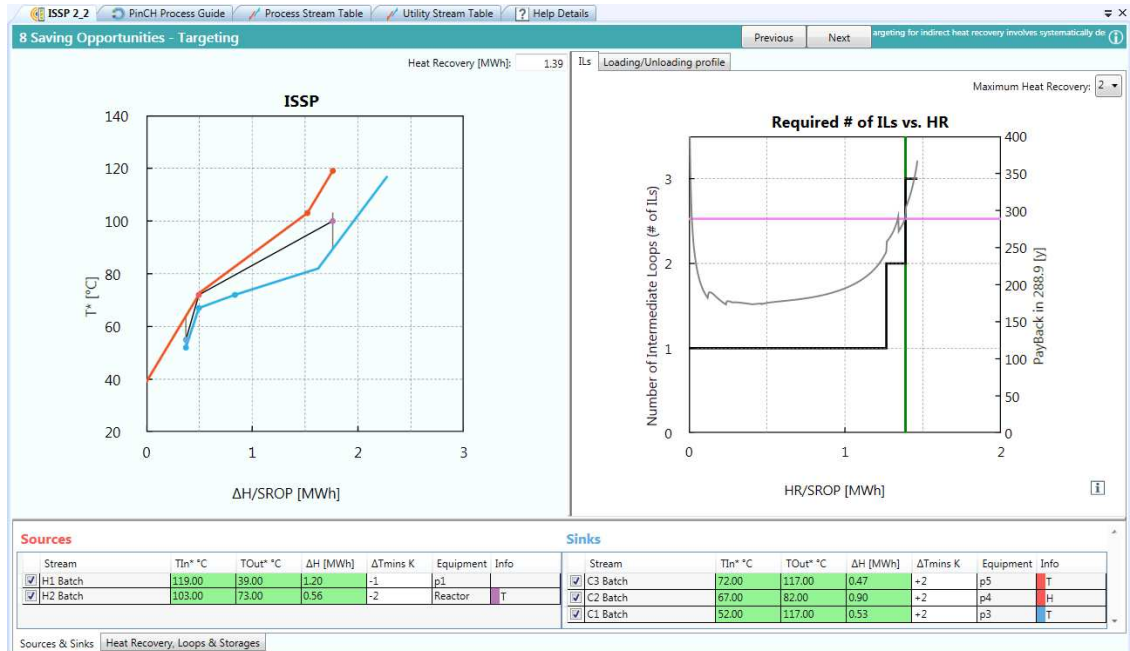

Fig. 10.2: Indirect heat recovery target result dockable window showing the main ISSP and Required # of ILs vs. HR charts and the Sources and Sinks table data grid.

ranges of these utilities provide enough driving force for the given process streams. These two utilities will need to be assigned as the default hot and cold utility in order to allow the internal energy balance to be closed. For the case of indirect heat recovery result **only a single hot and single cold utility are supported** (i.e. multiple utilities are not supported).

10.3.1 Indirect Heat Recovery Target Results

The indirect heat recovery target result consists of several key charts and result tables. In the following points are listed the main charts and tables with specific information related to each.

Indirect Source and Sink Profile Chart:

The Indirect Source and Sink Profile (ISSP) is used to determine the indirect heat recovery potential of a batch process. Indirect heat recovery is achieved using intermediate loops (IL) and heat storages (HS) (i.e. there is no direct heat transfer between any of the streams involved in the pinch analysis). This allows the full energy content of a stream to be captured and potentially used for heat recovery, regardless of when the stream occurs in time. An example

ISSP with a disconnected storage system (i.e. the two IL/HSs system has been separated into, for example, two different stratified tanks to allow setting the Thigh and Tlow values of each tank independently of each other) in the PinCH software is shown in Fig. 10.3.

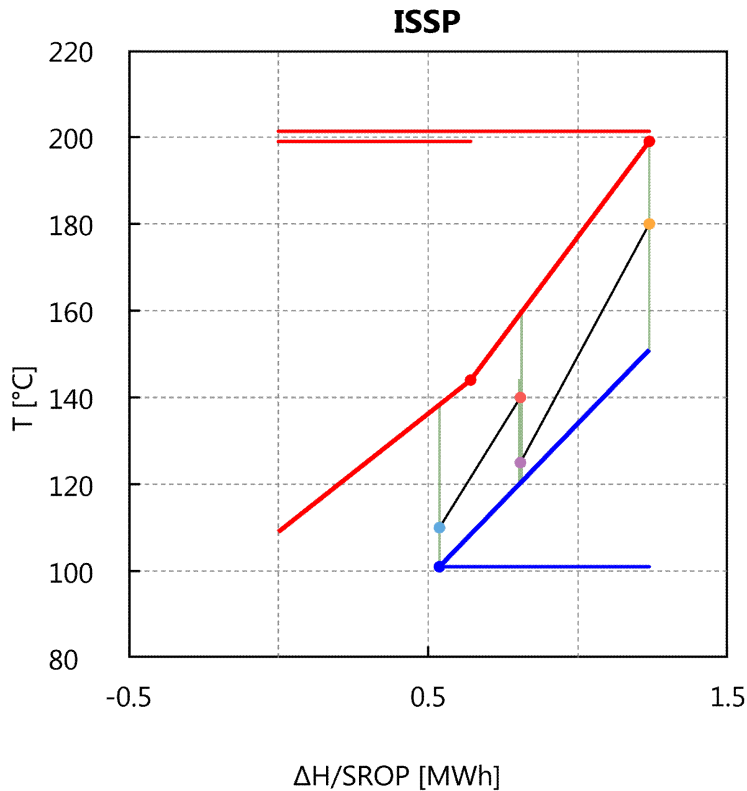

Fig. 10.3: Indirect Source and Sink Profile chart for a disconnected thermal energy storage system.

The ISSP is based on the time average model (TAM) originally defined to provide an absolute upper limit to the achievable HR in batch processes by simply averaging the flows over the period of the batch. This role of the TAM was later extended to include graphical conceptual design by applying the "vertical heat transfer model" to define enthalpy intervals in which heat is recovered from the hot streams to the cold streams through an IL/HS system. The "vertical model" is defined as pure counter-current heat exchange within the enthalpy interval. However, when integrating batch processes, the simultaneity of the hot and cold streams can not be guaranteed, so that the vertical model is applied to the individual streams rather than for the entire composite within the enthalpy interval. This means the heat exchangers are

placed in parallel on the IL/HS side as shown on the HESN in section 10.3.2 - Fig. 10.10. More detailed information in how to calculate the ISSP is shown in Appendix A.11

Note: When 50 or more streams are included in the ISSP then the source and sink profiles are defaulted to have no overlap. This behavior improves performance in first creating the ISSP and when opening a saved result.

Finally, as shown on Fig. 10.3 the individual streams can be shown (as horizontal lines) on the graph to indicate the temperature range of their supply and target temperatures. This can be activated on the properties window as discussed later in this section.

Sources and Sinks Table:

The sources and sink table lists process requirements for the batch process used in creating the ISSP. The calculated shifted temperatures and amount of available heat are shown in green. This allows the user to assess the effectiveness of each stream for HR in the storage system. For example, a stream with a low heat content relative to the others could be removed from the analysis to reduce complexity. This is simply done by deselecting the check box next to the stream name as shown in Fig. 10.4.

Sources							Sinks						
Stream	TIn° °C	TOut° °C	ΔH [MWh]	ΔTmins K	Equipment	Info	Stream	TIn° °C	TOut° °C	ΔH [MWh]	ΔTmins K	Equipment	Info
<input checked="" type="checkbox"/> H5 Product 140-40°C	139.00	39.00	1.00	-1	H5 Product 140-40°C_eq		<input type="checkbox"/> C2 Sump 110-111°C	111.00	112.00	0.48	+1	C2 Sump 110-111°C_eq	
<input checked="" type="checkbox"/> H4 Reactor 130-120°C	129.00	119.00	0.40	-1	H4 Reactor 130-120°C_eq	T	<input checked="" type="checkbox"/> C1 Feed 79-95°C	80.00	96.00	0.40	+1	C1 Feed 79-95°C_eq	T
<input type="checkbox"/> H3 Sumpproduct 110-40°C	101.00	31.00	0.11	-9	H3 Sumpproduct 110-40°C_eq		<input type="checkbox"/> C1 Feed 70-95°C	79.00	104.00	0.13	+9	C1 Feed 70-95°C_eq	
<input type="checkbox"/> H3 Sumpproduct 80-40°C	78.00	38.00	0.30	-2	H3 Sumpproduct 80-40°C_eq		<input checked="" type="checkbox"/> C3 Educt 50-90°C	51.00	91.00	0.64	+1	C3 Educt 50-90°C_eq	
<input type="checkbox"/> Product 76-40°C	71.00	35.00	0.18	-5	Copy of H5 Product 140-124°C Eq		<input type="checkbox"/> C1 Feed 40-54°C	49.00	63.00	0.07	+9	C1 Feed 40-54°C_eq	
<input type="checkbox"/> H2 Overheadproduct 79-59	70.00	50.00	0.07	-9	H2 Overheadproduct 79-59_eq								

Fig. 10.4: Sources and Sinks table to allow the selection of streams to be excluded from the ISSP analysis. In addition, the calculated $\Delta T_{min,s}$ can be manually set to change each streams priority for heat recovery.

The default $\Delta T_{min,s}$ values (see Appendix A.11) are also displayed and can be edited manually to essentially shift the priority of each stream for HR relative to the other streams as needed or to ensure a large enough temperature driving force between the stream and IL is available.

Finally, the Info column displays key information related to which streams create new assignment zones in effect acting as constraints in either temperature or enthalpy. Those stream that cause a high degree of complexity in the IL/HS systems (through the creation of additional assignment zones) can also be easily excluded from the ISSP. The Info box also notes if a stream contains segments. This information is important to check if the particular segment

is causing an assignment zone to be created and to decide if it is necessary. **The PinCH software considers all "convex" segments in the calculation of the assignment zones leading to a conservative design.**

Required # of IL/HSs vs. HR chart and Payback Chart:

To provide a quick overview of the IL/HS system design and the profitability, a chart showing the **minimum number of IL/HSs for a given HR** is available (Fig. 10.5). This value is calculated internally based on automatic placement of the Thigh and Tlow within the associated assignment zones assuming a connected IL/HS system over the entire HR range. These values are only defaults and are not necessarily the lowest cost, but are good immediate indications of the effectiveness of the design and which HR value to select.

Note: The initialization algorithm tries to place the Thigh and Tlow in the middle of the dynamic assignment zone shown in green. If unable to do so then simple criteria (such as 20% of the vertical distance to the zone boundary when only a vertical line assignment zone) are used.

In addition, the associated simple payback is calculated based on the total investment costs and the total utility savings. It serves as a rough indicator of the heat storage system's profitability and the optimal HR-value. The grey payback line on the chart is based on the automated initial placement of ILs as noted above. The investment costs and hence the payback, given a specific HR, can usually be significantly decreased by adequately changing temperatures and HR-values of the ILs (in the *Heat Recovery, Loops & Storages* tab). The pink line in the graph indicates the payback of the heat storage system with adapted values on the secondary y-axis. Further information on the creation of the assignment zones is in [19 - 21].

Note: Increasing the heat recovery also decreases the investment costs for HU and CU HEXs. This decrease is not taken into account with the payback calculation described above. It is therefore assumed that a) the heat recovery system is installed in an existing system and all HU and CU HEXs are already installed (and already paid for) OR despite of the heat recovery system, all HU and CU HEXs will have to be installed in any case (i.e. for securing operation in case the heat storage system runs empty). In case HU and CU HEXs can be abdicated in a new plant, the payback indicated in the graph is overestimated and the correct calculation would need to include the investment cost for the HU and CU heat exchangers.

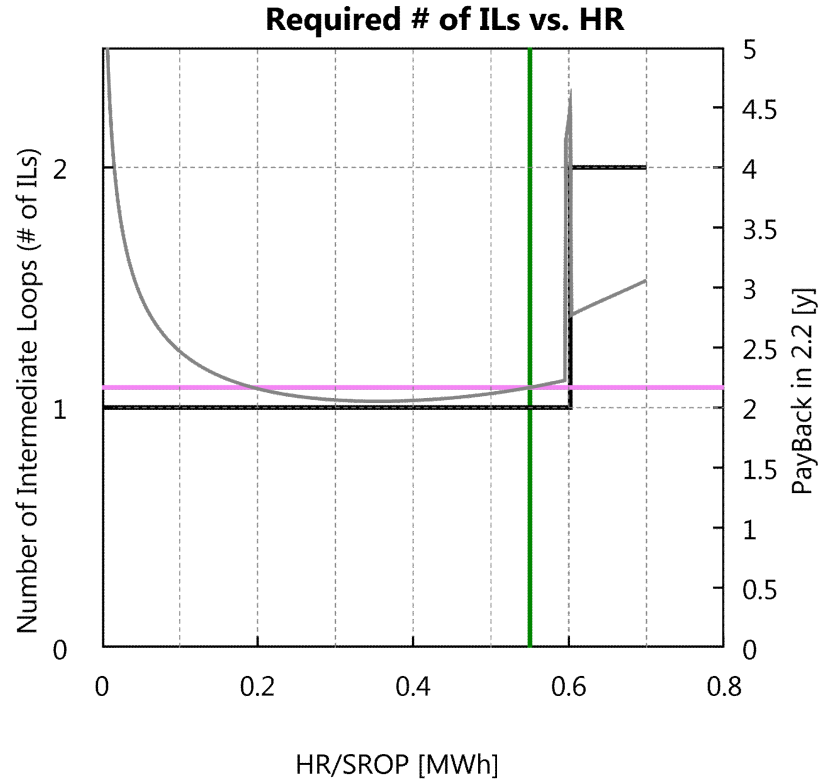

Fig. 10.5: Chart showing the minimum number of required intermediate loops and heat storages (IL/HSs) versus the amount of potential heat recovery. In addition the calculated simple payback versus the amount of potential heat recovery is shown on the second y-axis.

Loading / Unloading Chart:

The minimum storage capacity needed for the IL/HS system depends on the order of charging and discharging the stores from streams. This order is determined from the stream existence times defining the batch Gantt as well as the Batch Cycle Duration BCD. The result is the determination of the loading / unloading thermocline profile based on one stream repeat operation period (SROP). Using the ISSP, the direct allocation of stream to each IL/HS together with the sequence of streams during the repetition period allows the computing of the profile. For a stratified tank the ideal thermocline between each layer is shown (Fig. 10.6). Where for a FTVM each separate tank temperature is shown as individual lines. In both cases the profiles start and end at the same level since the proposed design is a over a repetition period.

Note: The loading / unloading profile represents ideal thermal energy storage

with no losses. To account for additional investment cost, a **Safety Factor** can be applied to the total volume by entering the percentage on the properties window of the ISSP target result. In practice this area will belong to one (or more) layer or, in the worst case, to a transition layer, depending on the initial conditions.

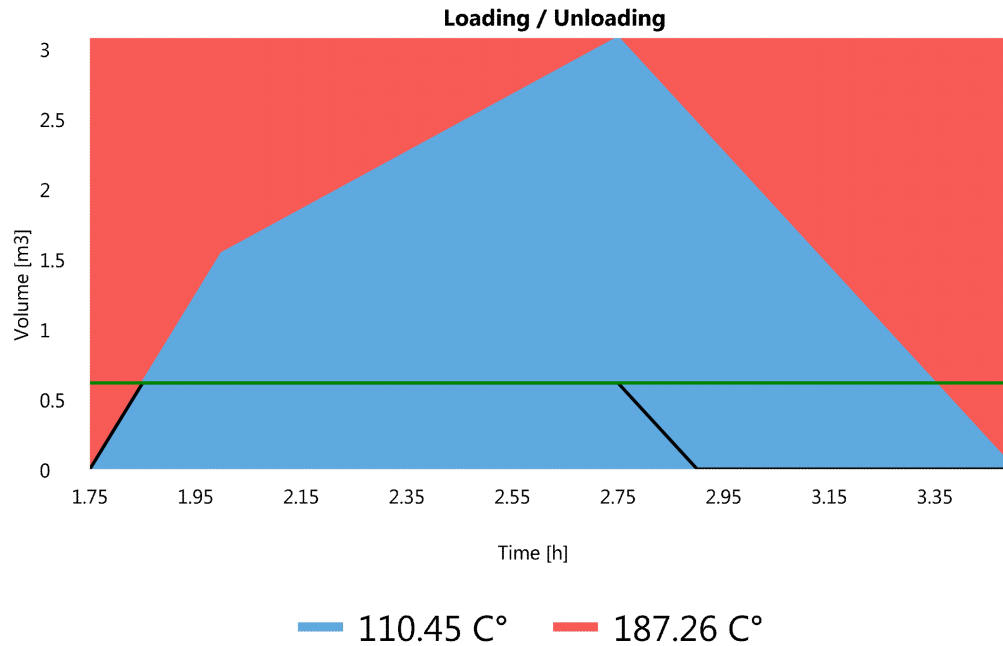

Fig. 10.6: Loading and unloading profile chart showing a single intermediate loop/heat storage system (i.e. with two temperature levels) for the given single batch stream repeat operation period (SROP). In addition, the green line shows the user supplied capacity limitation and the blackline shows the resulting restricted loading and unloading profile.

Capacity Limitation Analysis Chart:

The capacity limitation analysis chart shows the relation between the amount of potential heat recovery for a specified amount of storage volume. The chart is shown next to the loading and unloading chart when selecting the Next button on the Loading/Unloading tab. The analysis is limited presently to a single intermediate loop/heat storage (IL/HS).

Ignoring Streams in a Time Slice: To help improve the heat recovery potential in batch processes using capacity limitation, ignoring an stream in a particular time slice would be a way to control overflow in a storage to help minimize the required capacity. However, presently PinCH only supports the selecting / deselecting of an entire stream and not (as regards ISSP) at the time slice level. A workaround if needed is to modify the tstart / tstop in the stream table or use multiple instances of the same stream in different time slices.

Note: Simultaneous loading and unloading leads to Heat Recovery without requiring a storage. In the graph Capacity Limitation Analysis, the HR vs. Capacity line can therefore cross the y-axis at HR-values > 0 . However, the stream table is usually simplified (e.g. averaged values over a given duration, assumed periodic operation) and the simultaneity of streams might not be given in practice. Hence, at least for buffering small scale variations of the temporal model, and furthermore to allow some flexibility in operation, a storage is almost always necessary.

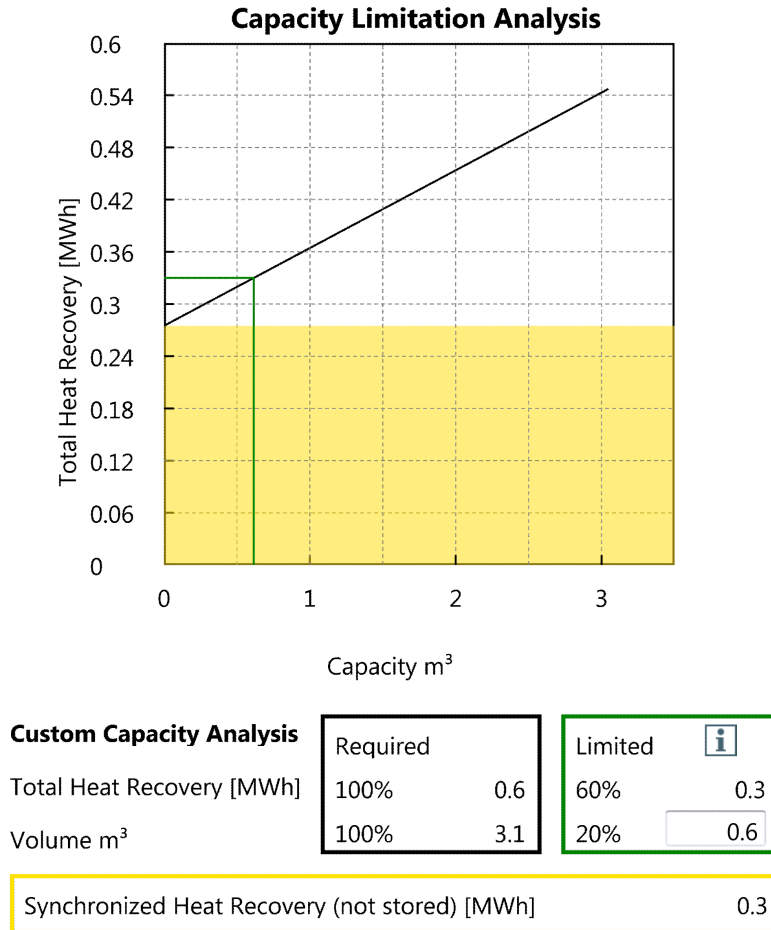

Fig. 10.7: Capacity limitation analysis chart showing the relation between the amount of heat recovery possible and the selected amount of storage volume (for a single intermediate loop/heat storage system). The amount of synchronized heat recovery possible (i.e. not needed to be stored) is shown in the yellow region.

Specification and Savings/Costs Tables:

The Specification table is important for modifying the design of the IL/HS system in order to systematically reduce the costs and complexity using the given key parameters that can be modified. Setting the overall HR given by the overlap of the source and sink profiles, results in the calculation of the necessary assignment zones. These zones represent the set of HESN designs which guarantee feasible heat transfer at all time of the SROP while minimizing the number of IL/HSs (see Appendix A.11).

Note: The implementation of the assignment zone algorithm in PinCH differ-

entiate between two types: 1) most restricted zones based on the intersection of possible assignment zones where temperature placement is always feasible, independent of the other enthalpy placements and 2) extended zones based on the union of possible assignment zones where the temperature placement within a zone is conditionally feasible and depends on the other enthalpy placements.

In the Specification table the user can change the amount of HR, Tlow and Thigh of each IL directly, but bounded by the calculated assignment zones.

Finally, the IL/HS system can be disconnected by simply deselecting the check box in the Connected column for a particular IL as shown in Fig. 10.8. An example disconnected ISSP is shown in Fig. 10.3.

Specification										Stratified		FTVM		HEX	
#IL	Connected	Storage Type	Media	T [°C]		HR/SROP [MWh]	Volume [m³]	Mass [t]	Storage Volume [m³]		Media in Storage [t]		#HEX	A HEX [m²]	
				low	high				low	high	low	high			
#2.1	<input type="checkbox"/>	Stratified	Water	125.0	180.0	0.4	3	3					2	71	
#1.1	<input checked="" type="checkbox"/>	Stratified	Water	110.0	140.0	0.3	4	4					3	48	
Sum						1	7	7					5	119	

Savings/Costs (Heat storage system only)										Stratified		FTVM		HEX	
#IL	Utility savings [CHF/y]		HR/y [MWh/y]	Total costs [CHF/y]		IL fix costs [CHF]	Storage CHF	Media CHF	Storage CHF		Media CHF		HEX CHF		
	cold	hot		CHF	CHF				low	high	low	high			
#2.1	1720	30'952	344	24'896	88'283	0	0	3					88'280		
#1.1	1080	19'448	216	20'663	73'272	0	0	4					73'268		
Sum	2'800	50'399	560	45'559	161'555	0	0	7					161'548		

Sources & Sinks: Heat Recovery, Loops & Storages

Fig. 10.8: ISSP system Specification and Savings/Cost data tables. The Specification table allows the direct configuration of the thermal energy storage system (i.e. Thigh or Tlow of each heat storage, amount of heat recovery for each heat storage, storage type, media type and connected or disconnected storages).

Shown in Fig. 10.8 is also the Savings/Costs table for the heat storage system only. The total investment cost based on the total heat exchanger area, mass of required media and the storage volume is calculated and displayed. Given the direct savings in hot and cold utility the simple payback can be calculated using the cost data entered on the Economic Data dialog as shown on Fig. 6.3.

The properties window of the indirect heat recovery target result can be used to modify the calculation and display of associated charts and data tables. Fig. 10.9 shows the parameters that can be selected. Of particular note is the ability to toggle the display of the streams shown on the chart (as shown on Fig. 10.3) and to change the default Initial Storage Type and Initial Media that is used when recalculating the ISSP when, for example, stream are included/excluded on the Sources and Sinks table (Fig. 10.8).

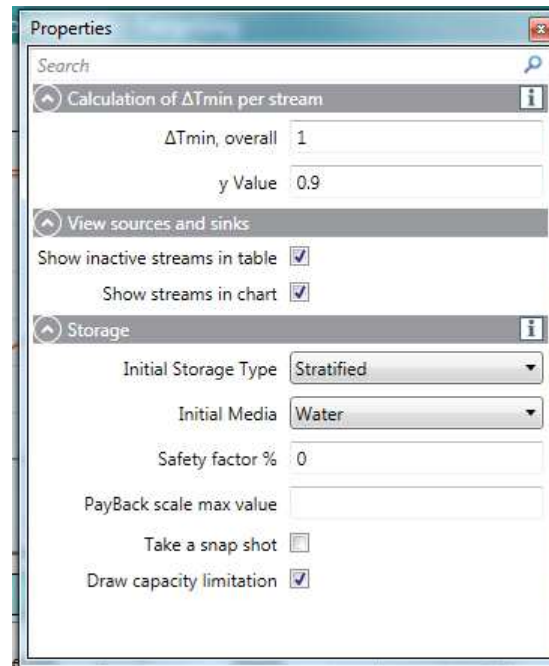

Fig. 10.9: Indirect heat recovery target result properties window showing the default settings.

The storage volume for each volume storage unit (VSU, i.e. Temperature level in a stratified tank or a single FTVM tank) is simply scaled according to the entered **Safety factor %**. This factor allows the user to quickly adjust the volume to provide a safety margin in the design as typically needed in TES design.

10.3.2 Heat Exchanger and Storage Network Schema

Based on the configuration result of the ISSP and the associated setting of the degrees of freedom (e.g. the number of IL/HSs, HR of each HS, temperature levels and overall heat recovery), the heat exchanger and storage network can be created. Given the assumption of vertical heat transfer in the ISSP the HESN design is given immediately. An example is shown in Fig. 10.10

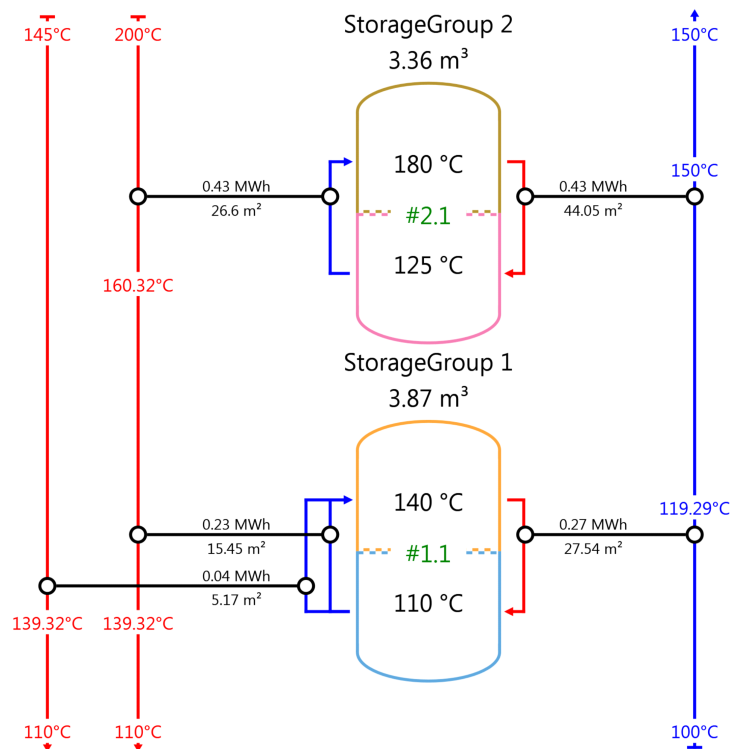

Fig. 10.10: Heat exchanger and storage network (HESN) for a disconnected system.

To View the Heat Exchanger and Storage Network (HESN):

1. Create an **Indirect Heat Recovery** target result as noted in section 10.3.
2. Right click on the newly added **Indirect Heat Recover node** and select **Show HESN Schema** to display the HESN result
3. All the nodes can be renamed after pressing F2

The HESN is readonly and is dynamically bound to the associated ISSP and the configured IL/HS system given in the Specification table. However, the

properties window of the HESN can be used to modify the display of the HESN. Fig. 10.11 shows the parameters that can be selected. **Of particular note is the ability to toggle the display of the mass flow rate on each branch IL.**

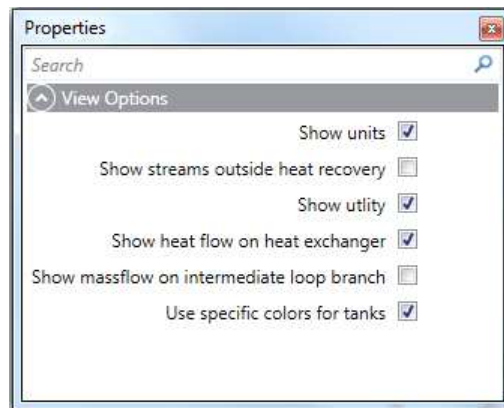

Fig. 10.11: Heat exchanger and storage network (HESN) chart properties window showing the default settings. Of particular note is the ability to show massflow on the intermediate loop branches.

10.3.3 Special Considerations with Shared Equipment

The increase in number of pieces of equipment that result from the overlap of consecutive batch processes (as defined by the Batch Cycle Duration (BCD), see section 9.2 and Appendix A.9) are handled in a special manner. The first important consideration is the calculation of the volume storage unit (VSU) (i.e. Temperature layer for a stratified tank or an FTVM tank) that includes the energy content of each piece of equipment from their associated streams. As the number of pieces of equipment increases then the amount of energy input and output must increase accordingly. As a result, the amount of energy transferred is the total amount shown on the HESN. In addition, as the total amount of energy is used in the calculation of the volumes and loading/unloading profiles.

However, another consideration is the handling of the display of the streams on the HESN. To save space and avoid showing too many streams, the following conditions are applied:

- If streams in the shared piece of equipment **have the same temperatures**, then only the stream with the largest HEX area is shown as a single stream

on the HESN. This approach also promotes the design idea to reuse a heat exchanger if possible.

- If the streams **have different temperatures** then they are all shown on the HESN regardless if they are in the same piece of equipment.

Note: Streams within the same equipment but having different T_{in} and T_{out} values are calculated and displayed separately (i.e. each stream is treated separately in its own equipment and heat exchanger). However, in practice, heat exchangers containing streams within the same IL and defined in the same equipment should, when ever possible during detailed design, be considered for reuse despite their differences in temperatures. The other area values are displayed on the HESN when placing the mouse over a heat exchanger to show the tooltip.

Finally, **streams in a shared equipment** that have isothermal **phase change (PC) segments** have to be handled in a special manner. Internally, this means that an algorithm uses a pseudo quality to proportion the amount of heat a particular PC segment transfers to a particular intermediate loop to the total amount of heat in the curve segment made up of the shared stream segments with phase change. This proportion is now used in calculating for each segment (in the shared equipment) the area required. The largest area is then displayed with the other areas shown in a tooltip. This algorithm design automatically handles the case of 2 IL/HSs that have a middle VSU temperature that divides up the phase change region defined by streams in a shared equipment on the ISSP curve. The pseudo quality at the middle temperature heat value for the IL is used to calculate a quality used in each stream segment as noted above.

It must be noted that in the case of *multiple* shared equipments with the same isothermal phase change segment temperatures, they each must be handled separately. This means a small delta is automatically applied of 0.1 K to each shared equipment temperatures with phase change and the algorithm applied as noted above for each individual shared equipment.

10.4 Indirect Heat Recovery Analysis Support Tools

To allow the user to quickly focus on the important information during the analysis of an indirect heat recovery Target Result, two workflow buttons

have been implemented. As seen in Fig. 10.2 a Previous and Next button are displayed in the header of the dockable window itself.

The *Previous* button shows the following charts and data grids:

- ISSP Chart
- Required # of IL/HS vs. HR Chart
- Sources and Sinks Tables

The *Next* button shows the following charts and data grids:

- ISSP Chart
- Loading and Unloading Profile Chart
- Capacity Limitation Chart
- Specification Data Grid
- Heat Storage Only Savings/Costs Data Grid

Note: Different combinations of charts and data grids can be arranged by selecting directly on the associated visualizer tabs. The sizing of each item can be changed by repositioning the window dividers. However, to quickly and conveniently return to the default setting simply select Previous or Next buttons.

Chapter 11

Integrate Energy Conversion Units

11.1 Introduction

An energy conversion unit (ECU) is a technique for transforming energy from a lower quality to a higher quality (i.e. temperature) to improve energy efficiency. This transformation allows better integration of waste heat into a process and is an effective investment opportunity when properly placed based on the pinch analysis method.

An ECU must be applied on the target result level. These ECUs allow the investigation of integrating such unit operations into the stream population for a given Target Result. In each case either one or more streams are inserted directly as new streams to be included in the target calculation. Starting with PinCH 3.0 is the ability to add an ECU to each operating case or time slice of an individual target result. However, only one type of ECU can be applied to each operating case/time slice.

11.2 Economic Calculations

Economic calculations for each ECU use a standard cost versus capacity equation expressed as a power law of the capacity. Each ECU has its own unique base quantity parameter given as follows:

- Heat Pump – Compressor Electricity
- Internal Combustion Engine – Generated Electricity

- Mechanical Vapour Recompression – Compressor Electricity
- Thermal Vapour Recompression – Total Mass Flow of Steam
- Organic Rankine Cycle – Generated Electricity

For the heat pump (HP), mechanical vapour recompression (MVR) and thermal vapour recompression (TVR) the calculated investment costs simply contain the remaining costs not including the heat exchanger costs as these are handled directly in the target area calculations. The following tables list the economic parameters and their values [14].

Tab. 11.1: ECU Materials of Construction Economic Factors Table

fm Materials of Construction	Value
Carbon steel (default)	1.0
Aluminium	1.3
Stainless steel (low grades)	2.4
Stainless steel (high grades)	3.4
Hastelloy C	3.6
Monel	4.1
Nickel and inconel	4.4
Titanium	5.8

Tab. 11.2: ECU Economic Pressure Factors Table

fp pressure	Value
0.01 bar	2.0
0.1 bar	1.3
0.5 to 7 bar (default)	1.0
50 bar	1.5
100 bar	1.9

Tab. 11.3: ECU Economic Temperature Factors Table

ft Temperature	Value
0 to 100°C (default)	1.0
300°C	1.6
500°C	2.1

For the internal combustion engine, a module cost factor has been fitted based on the data given in [15] for a standard CHP unit using natural gas. This

module cost data already includes an installation factor for transport, installation and startup. The materials of construction, pressure and temperature dependency factor shown above are not applied.

The default specific cost factors for each ECU are shown in the figures within the following sections.

11.3 ECU Types

The main ECUs include the heat pump, mechanical vapour recompression, thermal vapour recompression and the organic rankine cycle. Although not strictly an ECU, the internal combustion engine has also been included in this section.

11.3.1 Heat Pump

The heat pump models a standard heat pump cycle that includes a regenerator heat exchanger as shown in Appendix A.2. After setting the correct parameters for the heat pump, two streams are created and inserted into the target result stream population - a condenser stream and an evaporator stream (see Figure 11.1). Changes to the parameters automatically update the Target Result immediately unless an infeasible value is entered resulting in non-convergence results (e.g. entered condensation temperature above critical temperature).

Grand Composite Curve:

To aid in the sizing of a heat pump ECU, different forms of the **Grand Composite Curve (GCC)** have been included in the Heat Pump Optimization group box. The different forms of the GCC include the following:

1. Process-Streams only
2. Process- and ECU-Streams w/o own Streams
3. Process- and all ECU-Streams

Option 1 is used to quickly see the original GCC before any ECU streams have been included.

Option 2 shows the GCC when all other ECU streams have been included and the ECU of the present heat pump are not included (this GCC is most effective for setting the temperature and power levels of the present heat pump).

Option 3 displays the GCC with all ECU streams included to see how the GCC of the associated target result operating case or time slice looks.

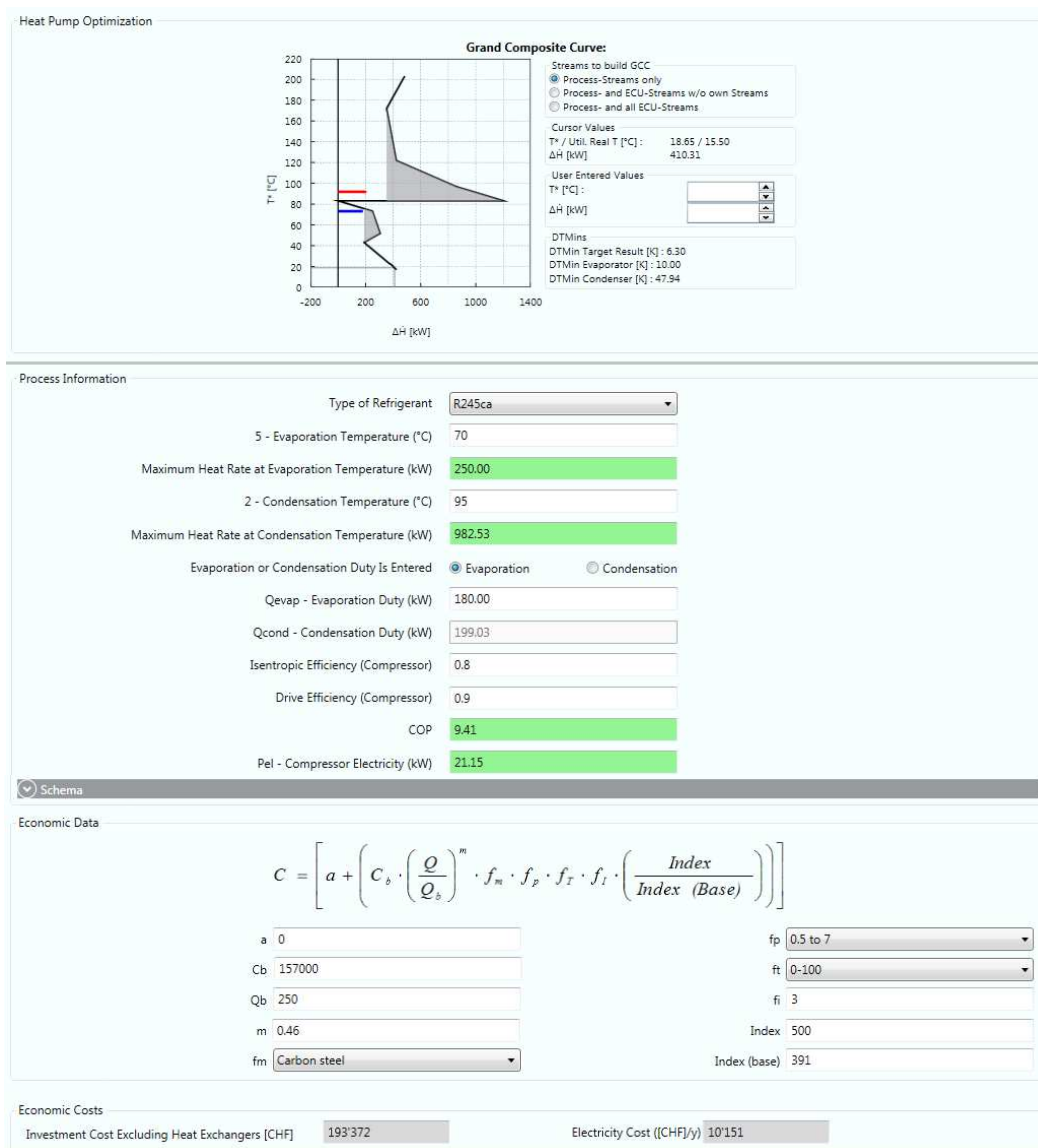

Fig. 11.1: Heat Pump ECU Dialog

The input parameters of the heat pump are described in Table 11.4.

The coefficient of performance has been added to display the calculated COP of the heat pump based on the thermodynamic cycle.

Note: Please see chapter 14.1 for information regarding the economic data parameters. The base quantity for the heat pump is the **compressor electrical power**.

Tab. 11.4: Heat Pump Input Parameters

Heat Pump Parameters	Description	Units
Type of Refrigerant	Refrigerant used in the thermodynamic cycle calculation	–
Evaporation Temperature	Temperature in the evaporator at which the refrigerant evaporates	°C
Maximum Heat Rate at Evaporation Temperature	The heat rate measured from the GCC of the original composite curve before the ECU is added at the given evaporation temperature	kW
Condensation Temperature	Temperature in the condenser at which the refrigerant condenses	°C
Maximum Heat Rate at Condensation Temperature	The heat rate measured from the GCC of the original composite curve before the ECU is added at the given condensation temperature	kW
Evaporation or Condensation Duty is Entered	Flag to set if either the evaporation or condensation duty is entered (Given this value the other is calculated)	–
Evaporation Duty	The duty of the heat transferred in the evaporator	kW
Condensation Duty	The duty of the heat transferred in the condenser	kW
Isentropic Efficiency	Isentropic efficiency of compressor process	–
Drive Efficiency	Efficiency which includes mechanical and electrical losses	–
COP	Overall efficiency of the heat pump	–
Pel - Compressor Electricity	Total electrical requirement to operate the compressor	kW
Investment Cost Excluding Heat Exchangers	Total investment cost for heat pump components not including the heat exchanger costs	CHF
Electricity Costs	Costs of electricity based on the price set in the global economic dialog	CHF/ year

11.3.2 Internal Combustion Engine

The internal combustion engine calculation is used for assessing the heat integration potential of a combined heat and power unit (CHP). Details related to the algorithm and other calculation aspects are reviewed in Appendix A.3. After setting the correct parameters for the engine, three streams are created and inserted into the target result stream population - a water stream, an oil stream and an exhaust air stream (see Fig. 11.2). Changes to the parameters automatically update the target result immediately unless an infeasible value is entered or non-convergence results.

9 - Internal Combustion Engine The internal combustion engine energy conversion unit is used to model combined heat and power units and integrate waste heat

Process Information

Pel kW: 500

Exhaust Gas	450	°C to	80	°C	243.74	kW
Engine Water Cooling	90	°C to	70	°C	0.7500	kW/kW
Engine Oil Cooling	90	°C to	70	°C	0.0000	kW/kW
						375.00
						0.00

Combustion

Fuel Mass Flow	0.03181	kg/s	Air Factor (λ)	1.1
Air Relative Humidity	50.55	%	Air Temperature	15.00
				°C

Methane CH4	0.874	mol/mol	Ethane C2H6	0.047	mol/mol
Propane C3H8	0.012	mol/mol	Butane C4H10	0.005	mol/mol
Nitrogen N2	0.049	mol/mol	Carbon Dioxide CO2	0.013	mol/mol

Economic Data

$$C = \left[a + \left(C_b \cdot \left(\frac{Q}{Q_b} \right)^m \cdot f_m \cdot f_p \cdot f_T \cdot f_I \cdot \left(\frac{Index}{Index (Base)} \right) \right) \right]$$

a	0	fp	0.5 to 7
Cb	110000	ft	0-100
Qb	500	fi	3
m	0.539	Index	500
fm	Carbon steel	Index (base)	500

Economic Costs

Module Investment Cost [CHF]: 330'000

Fig. 11.2: Internal Combustion Engine ECU Parameter Dialog. Module based economic parameters are used for the Economic Data [15].

The parameters of the engine are described in Table 11.5. The key parameter is the desired electrical power generation (Pel) expected from the internal combustion engine. This value is typically used by manufactures to specify the capacity of the chosen engine.

Note: Please see Chapter 14.1 for information regarding the economic data parameters. The base quantity for the internal combustion engine is the **generated electrical power Pel**.

Tab. 11.5: Internal Combustion Engine Parameters

Engine Parameters	Description	Units
Pel	Generated electrical power of the engine	kW
Exhaust Gas temperature range	Start and end temperature of the exhaust gas stream	°C
Water temperature range	Start and end temperature of the water stream	°C
Oil temperature range	Start and end temperature of the oil stream	°C
Water heat duty load ratio	Heat duty load ratio used to calculate the energy that can be derived from the created water stream	–
Oil heat duty load ratio	Heat duty load ratio used to calculate the energy that can be derived from the created oil stream	–
Exhaust Gas stream heat recovery	Heat recovery for the exhaust gas stream based on flame temperature calculation	kW
Water stream heat recovery	Heat recovery approximated for the water stream	kW
Oil stream heat recovery	Heat recovery approximated for the oil stream	kW
Fuel mass flow	Flow of the gas fuel	kg/s
Air Factor	Ratio of air to fuel flow rate	–
Fuel Composition	Mole fractions of methane, ethane, propane and butane in the fuel feed	mole/mole
Module Investment Cost	Total investment cost for the engine components outside the combustion gas exchanger cost	CHF

Note: The mass flow rate of the combustion gas is calculated and displayed on a dry basis as is the norm in engineering calculations involving humid air streams such as combustion gas.

The investment cost for the internal combustion engine is based on the module cost given in [15]. Given this module cost basis the weighting factors for

temperature, pressure and materials of construction have been disabled. The cost for internal heat exchangers are included in the module cost and only those costs for heat exchangers to handle additional cooling for the exhaust gas, water and oil can be handled separately in targeting or in detailed HEN design.

11.3.3 Mechanical Vapour Recompression

The mechanical vapour recompression (MVR) models a standard compression cycle as shown in Appendix A.4. After setting the correct parameters for the MVR and selecting a water vapour stream to be upgraded in the compressor, two new streams are created and inserted into the target result stream population (upgraded and reduced). The originally selected stream is removed (see Fig. 11.3) from the stream population. Changes to the parameters automatically update the target result immediately unless an infeasible value is entered or non-convergence results.

Grand Composite Curve:

To aid in the sizing of a MVR ECU different forms of the **Grand Composite Curve (GCC)** have been included in the MVR Optimization group box. The different forms of the GCC include the following:

1. Process-Streams only
2. Process- and ECU-Streams w/o own Streams
3. Process- and all ECU-Streams

Option 1 is used to quickly see the original GCC before any ECU streams have been included.

Option 2 shows the GCC when all other ECU streams have been included and the ECU of the present MVR are not included (this GCC is most effective for setting the temperature and power levels of the present MVR).

Option 3 displays the GCC with all ECU streams included to see how the GCC of the associated target result operating case or time slice looks.

Note: The water vapour stream to be upgraded must be defined as **R718 fluid** which uses the equation of state given in [4].

9 - Mechanical Vapour Recompression The mechanical vapour recompression energy conversion units can be used to upgrade a water vapour stream and re-integrate it into a process.

MVR Optimization

Process Information

Vapour Stream To Upgrade: ⓘ

Condensation Temperature - Upgraded Vapour (C):

Maximum Heat Rate at Condensation Temperature (kW):

Total Heat Rate of Selected Vapour Stream (kW):

Required Mass Flow of Upgraded Vapour Stream (kg/s):

Isentropic Efficiency (Compressor):

Drive Efficiency (Compressor):

Pel - Compressor Electricity (kW):

Schema

Economic Data

$$C = \left[a + \left(C_b \cdot \left(\frac{Q}{Q_b} \right)^m \cdot f_m \cdot f_p \cdot f_T \cdot f_I \cdot \left(\frac{Index}{Index (Base)} \right) \right) \right]$$

a: fp:

Cb: ft:

Qb: fi:

m: Index:

fm: Index (base):

Economic Costs

Investment Cost Excluding Heat Exchangers (CHF): Electricity Cost (CHF/y): ⓘ

Fig. 11.3: Mechanical Vapour Recompression ECU Parameter Dialog

The parameters of the MVR dialog are described in the following table.

Note: Please see Chapter 14.1 for information regarding the economic data parameters. If the selected Vapour Stream to Upgrade exists in multiple pieces of equipment the investment and operating costs & # will be increased proportionally due to the greater P_{el} necessary for each equipment. The base quantity for the MVR is the compressor **electrical power**.

Mechanical Vapour Recompression Parameters	Description	Units
Vapour Stream to Upgrade	Water vapour stream to be upgraded by passing through the compressor (limited to refrigerant R718 water fluid)	–
Condensation Temperature - Upgraded Vapour	Temperature at which the upgraded vapour stream it to condense at	°C
Maximum Heat Rate at Condensation Temperature	The heat rate measured from the GCC of the original composite curve before the ECU is added at the given condensation temperature	kW
Heat Rate of Selected Waste Heat stream	The heat rate taken directly from the selected waste heat stream	kW
Mass Flow Rate of Selected Waste Heat Stream	Flow rate portion of the waste heat stream to be upgraded in the compressor	kg/s
Isentropic Efficiency	Isentropic efficiency of the compressor process	–
Drive Efficiency	Efficiency which includes mechanical and electrical losses	–
Investment Cost Excluding Heat Exchangers	Total investment cost for MVR components not including the heat exchanger costs	CHF
Electricity Cost	Cost of electricity based on the price set in the global economic dialog	CHF/year

11.3.4 Thermal Vapour Recompression

The thermal vapour recompression (TVR) models a standard ejector as shown in Appendix A.5. After setting the correct parameters for the TVR and selecting the water vapour stream to be upgraded by steam injection, two new streams are created and inserted into the target result stream population (upgraded and reduced). The originally selected stream is removed (see Fig. 11.4) from the stream population. Changes to the parameters automatically update the target result immediately unless an infeasible value is entered or non-convergence results.

Grand Composite Curve:

To aid in the sizing of a TVR ECU different forms of the **Grand Composite Curve (GCC)** have been included in the TVR Optimization group box. The different forms of the GCC include the following:

1. Process-Streams only
2. Process- and ECU-Streams w/o own Streams
3. Process- and all ECU-Streams

Option 1. is used to quickly see the original GCC before any ECU streams have been included.

Option 2. shows the GCC when all other ECU streams have been included and the ECU of the present TVR are not included (this GCC is most effective for the temperature and power levels of the present TVR).

Option 3. displays the GCC with all ECU streams included to see how the GCC of the associated target result operating case or time slice looks.

Note: The water vapour stream to be upgrade must be defined as **R718 (Water)** fluid which uses the equation of state given in [4].

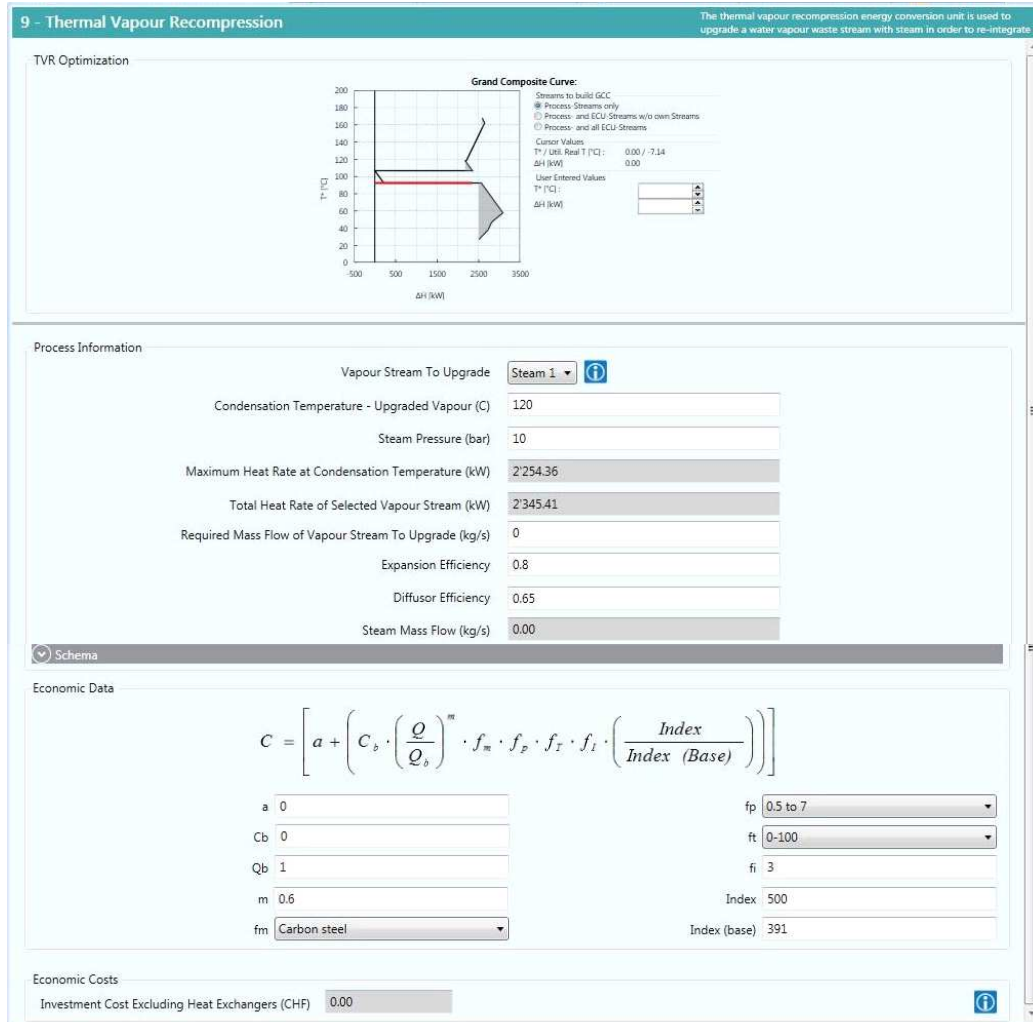

Fig. 11.4: Thermal Vapour Recompression ECU Parameter Dialog

The parameters of the TVR are described in the following table.

Note: Please see section 14.1 for information regarding the economic data parameters. If the selected Vapour Stream to Upgrade exists in multiple pieces of equipment the investment and operating costs will be increased proportionally due to the greater steam rate necessary for each equipment. The base quantity for the TVR is the **total steam mass flow rate**.

Thermal Vapour Recompression Parameters	Description	Units
Required Mass Flow of Vapour Stream to Upgrade	Water vapour stream to be upgraded by passing through the TVR (limited to refrigerant R718 water fluid)	kg/s
Condensation temperature	Temperature at which the upgraded vapour stream is to condense	°C
Steam Pressure	Pressure of saturated steam used to upgrade the water vapour stream to the required condensation temperature	bar
Maximum Heat Rate at Condensation Temperature	The heat rate measured from the GCC of the original composite curve before the ECU is added at the given condensation temperature	kW
Heat Rate of Selected Waste Heat Stream	The heat rate taken directly from the selected waste heat vapour stream	kW
Required Mass Flow Rate of Vapour Stream To Upgrade	Flow rate of waste heat vapour stream to be upgraded in the compressor	kg/s
Expansion Efficiency	Efficiency of the expansion process	–
Drive Efficiency	Efficiency which includes mechanical and electrical losses	–
Steam Mass Flow Rate	Calculated mass flow rate of required steam to upgrade the waste heat stream to the required condensation temperature	kg/s
Investment Cost Excluding Heat Exchangers	Total investment cost for TVR components not including the heat exchanger costs	CHF

11.3.5 Organic Rankine Cycle

There are two common variations of the Organic Rankine Cycle (ORC) that can be modeled. They are the “basic ORC” (Figure 11.5 (a)) and the “regenerative ORC”(Figure 11.5 (b)). In PinCH at present only the basic ORC type is modelled and it is assumed that an intermediate loop (IL) will be used to transfer heat from the process to the evaporator. This assumption of an IL decouples the investment cost of the ORC from the HEN grid area calculation allowing a module cost to be used directly.

Once the correct parameters for the ORC have been set, one stream will be created and inserted into the target result stream population. The stream modeled in PinCH is the evaporator stream of the IL. Changes to the parameters automatically update the Target Result immediately unless an infeasible value is entered resulting in non-convergence results.

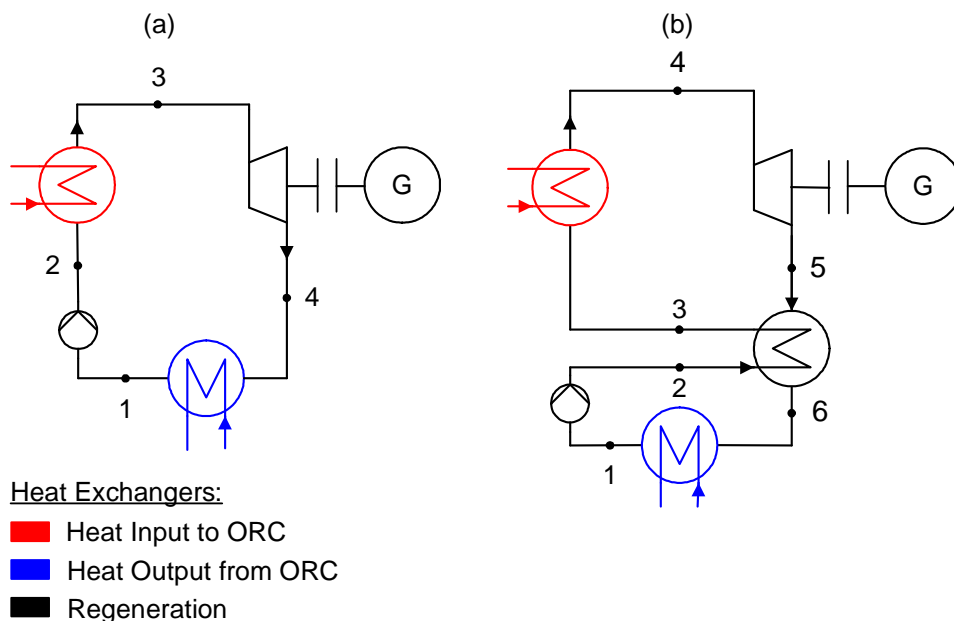

Fig. 11.5: Basic and Regenerative ORCs showing the main streams and associated heat exchangers.

Grand Composite Curve:

To aid in the sizing of a ORC ECU, different forms of the **Grand Composite Curve (GCC)** have been included in the ORC Optimization group box. The different forms of the GCC include the following:

1. Process-Streams only
2. Process- and ECU-Streams w/o own Streams
3. Process- and all ECU-Streams

Option 1 is used to quickly see the original GCC before any ECU streams have been included.

Option 2 shows the GCC when all other ECU streams have been included and the ECU of the present heat pump are not included (this GCC is most effective for setting the temperature and power levels of the present heat pump).

Option 3 displays the GCC with all ECU streams included to see how the GCC of the associated target result operating case or time slice looks.

Note: In the PinCH software only the values for the white fields need to be entered; green fields will be calculated automatically (Figure 11.6).

Displayed on this background process GCC of the PinCH ORC ECU dialog are **the IL stream and ORC evaporation stream**. This helps to check if the ORC is properly integrated relative to the process GCC. The IL on the process side is the key stream that is modeled in PinCH and included in the target result and HEN design. Each has been shifted according to the process ΔT_{min} . All the other streams are also calculated internally in the thermodynamic cycle calculation. More information is given in Appendix A.6 and how to integrate the ORC ECU in a target result is in Section 11.4.

Note: Presently, only the IL stream and evaporation stream are displayed on the GCC of the PinCH ORC ECU dialog. Also, the ability to set a separate ORC ΔT_{min} is not yet available.

The input parameters of the ORC are described in Table 11.4. Please see Chapter 14 “List of Symbols” for information regarding the economic data parameters. The base quantity for the ORC is the **net amount of generated electricity**.

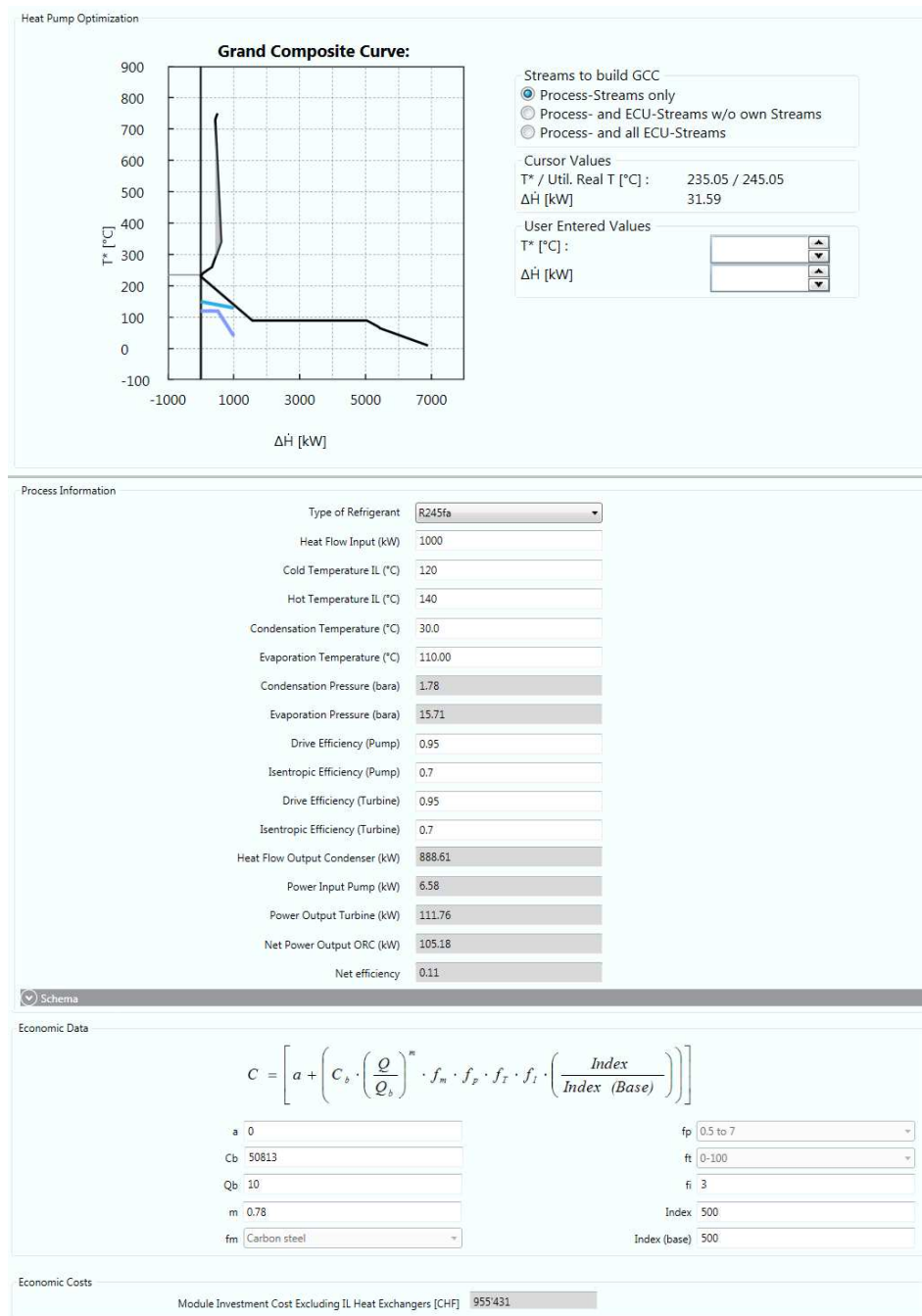

Fig. 11.6: Organic Rankine Cycle ECU dialog showing the placement of the intermediate loop (IL) stream and the associated refrigerant evaporation on the GCC as well as key process information and economic data.

Tab. 11.6: ORC Input and Calculated Parameters

ORC Parameters	Description	Units
Heat Input	The heat flow removed from the process and used in the ORC	kW
Cold Temperature IL	The evaporator inlet temperature of the IL	°C
Hot Temperature IL	The evaporator outlet temperature of the IL	°C
Working Fluid	The organic fluid used for the ORC	–
Minimum Temperature Difference ORC	The minimum temperature difference to be used in the ORC is defined by the user	K
Condensation Temperature	Temperature during condensation of the organic working medium in the condenser of the ORC	°C
Condensation Pressure	Pressure in the condenser of the ORC during condensation	bar(a)
Evaporation Temperature	Temperature during evaporation of the organic working medium in the evaporator of the ORC	°C
Evaporation Pressure	Pressure in the evaporator of the ORC during evaporation	bar(a)
Drive Efficiency Pump	Efficiency of the pump including mechanical and electrical losses	–
Isentropic Efficiency Pump	Isentropic efficiency of the pump	–
Drive Efficiency Turbine	Efficiency of the turbine including mechanical and electrical losses	–
Isentropic Efficiency Turbine	Isentropic efficiency of the turbine	–
Heat Output Condenser	The heat output over the condenser of the ORC	kW
Power Input Pump	The electrical power $P_{el,pump}$ required to operate the pump	kW
Power Output Turbine	The electrical power $P_{el,turb}$ output by the turbine	kW
Net Power Output ORC	The absolute value of the turbine output power $P_{el,turb}$ less the absolute value of the power input to the pump $P_{el,pump}$	kW
Overall Efficiency	The ratio of the net power output by the ORC to the heat input Q_{in} into the ORC	–

11.4 How to Integrate an ECU

In order to integrate an ECU a target result has to be first created as shown in chapter 7.3. An ECU belongs to a particular target result and is dependent on the associated set of streams assigned when selecting the processes for the particular target group. If a target result contains multiple operating cases or is a single product batch process with multiple time slices then an ECU can be selected for each operating case or time slice. However, only a single instance of a particular ECU type can be added per operating case or time slice (e.g. only one heat pump instance per operating case or time slice).

To integrate an ECU:

1. Select and highlight the particular **Target Result node** in the Target Explorer
2. Right click on the **Target Result node** to view the context menu and select **Add Energy Conversion Unit... > Add Heat Pump... > <OC1...OCn>**

Note: either operating cases (OCs) or batch process time slices (TSSs) can be selected.

3. Enter the appropriate process information on the ECU mask to configure the ECU according to the desired sizing

Note: Presently PinCH 3.2 does not yet fully support the integration of ECUs when a MOC Group has been defined with semi-continuous processes. Therefore, it is recommended to model each operating case separately in this case and not use the MOC group.

Chapter 12

Turn Saving Opportunities into HENs

12.1 Introduction

Following the calculation of a Target Result as discussed in section 7, a detailed heat exchanger network (HEN) design can be developed. This last step (step 10 - section 3.1) of the PinCH process requires substantial effort as there can be many possible solutions that need to be evaluated and compared. Also, in the case of retrofitting an existing process, the user will be required to balance the need to derive a network that achieves the calculated energy and cost targets with the realities and constraints of existing capital expenditure. It is a difficult process; however, the HEN design capabilities of PinCH provide an easy framework to rapidly develop new designs and to compare them. In PinCH there are three main types of HEN grids:

1. MER HEN Grid
2. Relaxed HEN Grid
3. HEN Grid which Includes Soft Stream Parts

In all cases can either a fully balanced HEN grid, which includes all intermediate utilities, or a grid with just default hot and cold utilities be created.

In order to create a heat exchanger network with maximum energy recovery (MER), the network is divided into two separate parts by the pinch temperature (a part that is entirely above the pinch line and a part that is entirely

below as shown in Fig. 12.1. This figure highlights many of the key user interface graphical components available on the PinCH HEN grid before beginning to build the network. As can be seen in the figure, two completely independent thermodynamic systems are formed that can be evaluated independently from each other (one above the pinch temperature and one below the pinch temperature). This division aids in reducing the complexity of the design problem and maintains one of the key pinch design rules of ensuring not to transfer heat across the pinch. The theory and documentation of the pinch design rules are not covered in this manual and the reader is recommended to review references [1 - 2],[5 - 10] and [14].

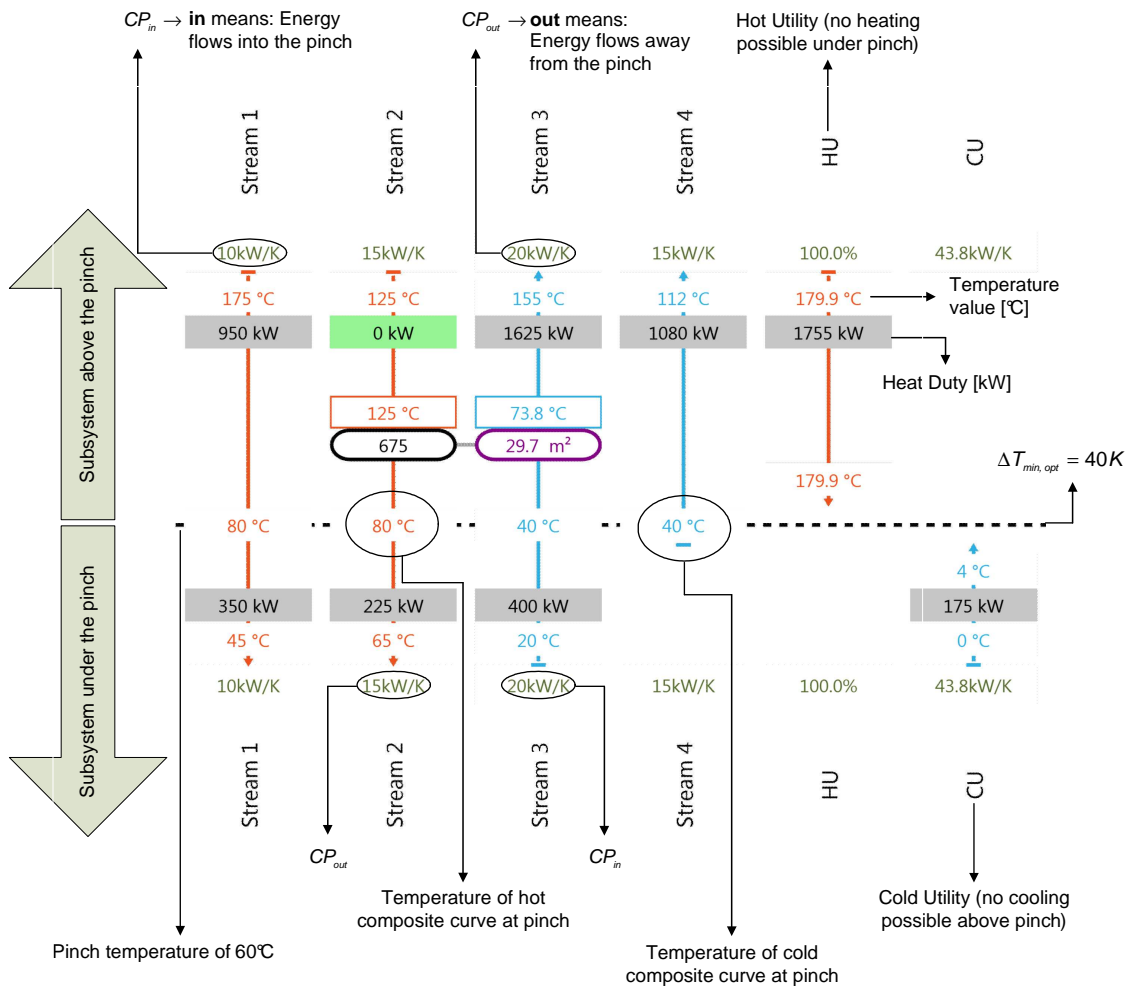

Fig. 12.1: Heat Exchanger Network Grid Parts

12.2 How to Create a HEN Grid

A HEN grid is bound to a particular Target Result and its corresponding ΔT_{min} for the given composite curve. Therefore, upon creating a HEN grid the pinch temperature and the associated utility values and streams are used to initialize the streams on the HEN grid.

To Create a MER HEN Grid:

1. Create a Target Result (see section 6).
2. Right click on the node of the created Target Result and select **Add HEN**
-> **Add MER HEN**.

Note: If multiple utilities have been included in the Target Result a message box will appear asking if you would like to create either a balanced grid, which includes all the internal utilities, or a standard MER HEN grid where only the default Hot and Cold Utility are included.

A Relaxed HEN Grid allows the evaluation and analysis of an existing or retrofit network in order to compare with the MER HEN grid designs. Cross pinch heat transfer is represented by a diagonal line connecting a hot and cold stream heat exchanger (whereas non-cross pinch heat transfer is always shown with horizontally placed heat exchangers). In addition, ΔT_{min} is allowed to be not be respected permitting heat exchanger connection to be made where this value is less than that specified in the Target Result.

To create a Relaxed HEN Grid:

1. Create a Target Result (see section 7).
2. Right click on the node of the created Target Result and select **Add HEN**
> **Add Relaxed HEN**.

A HEN Grid with Soft Stream Parts allows the design of HEN grids which include the soft stream parts that were excluded in the Targeting calculation (see sections 4 and 7). The soft energy that was excluded is shown in a Soft Pool graphical object which allows the exceeding of the calculated MER values for the hot and cold utilities. This ensures the HEN grid energy balance

can be completed, yet provides the flexibility for the user to create HEN designs that use the soft parts when necessary.

Note: This functionality is only recommended for expert users as a considerable amount of knowledge and experience is necessary in order to make the correct decision when to violate the MER design and use such soft streams directly.

12.3 Adding an Heat Exchanger

Heat exchanger matches can be easily added to the HEN grid using drag and drop functionality. The connection of two streams is limited by several key rules:

- Only a hot and a cold stream can be matched together
- Temperature crosses are not allowed
- The process ΔT_{min} must be respected (except for a Relaxed HEN Grid)
- The energy balance must be maintained

Fig. 12.2 illustrates an heat exchanger network grid with several heat exchangers added to a MER HEN design.

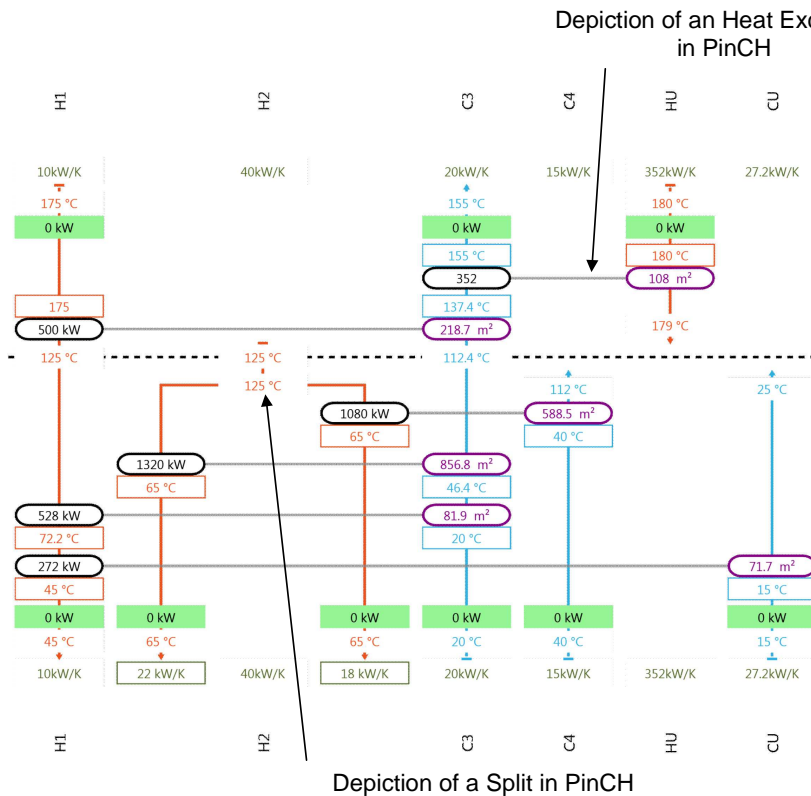

Fig. 12.2: Depiction of Heat Exchangers and Stream Split on HEN Grid

Note: PinCH will allow an HEX to exceed its energy balance limitation, but will mark the heat exchanger in red.

How to Add an Heat Exchanger:

1. Create a **HEN Grid**
2. Left click on a hot stream to **add a stream part**
3. Left click on a cold stream to add a stream part (Note: Ensure the MC_p rule based on the Pinch Design Method is maintained - MC_p of a stream going in a direction away from the pinch is greater than the MC_p of a stream going towards the pinch)
4. Left click on one of the newly added stream parts and **hold and drag** to the other stream part (ensure both stream parts are on the same vertical row as diagonal placement is not allowed for cross pinch heat exchange)
5. Release the left mouse button to create the match.

6. Double click in the HEX duty box to **tick-off** the entire duty of one of the stream (Note: According to the Pinch Design Method, it is recommended to always use the entire duty of one of the streams in a match)
7. Optionally, the temperature coming out of the stream parts can be directly specified

Note: PinCH will automatically check for the pinch design rules and ensure the energy balance is maintained. If the pinch design rules are not met then matching stream parts will be disabled. In addition, if an exchanger becomes pinched internally PinCH will only tick-off the duty up to the point of maintaining the ΔT_{min} .

12.4 Splitting and Merging

The ability to split a stream is very important in order to be able to completing a HEN design and not be limited by the MC_p values of the streams above and below the pinch. The rules of when to split a stream are not covered in this document. However, the user is encourage to review the following references for more information [1 - 2],[5] and [10].

How to Split a Stream:

1. Create a MER HEN Grid
2. Left click on either a hot stream or a cold stream and select Split Stream
3. Select the MC_p box associated with one of the branches and enter a new MC_p value

Note: PinCH will automatically update the other MC_p value and adjust the energy duties in each branch. Connections to other appropriate streams can now be made (see Fig. 12.3).

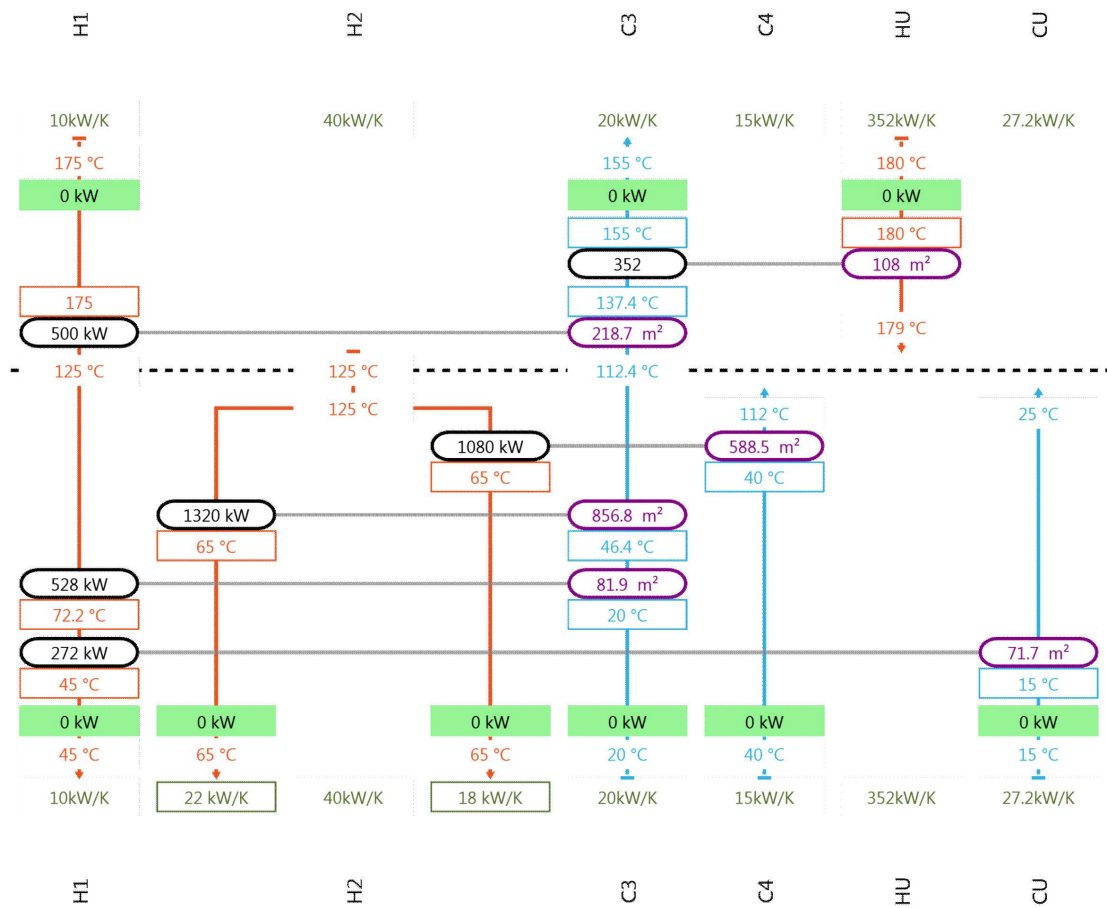

Fig. 12.3: Completed MER HEN Design Showing a Split

Merging is limited to single streams that were originally split. The merge must be isothermal and require the placing of a stream part on each split branch before merging.

How to Merge Stream Branches:

1. Create a **MER HEN Grid**
2. **Split a stream**
3. Add a stream part to each created stream branch
4. Left click on either branch and select **Merge Branches**

- Select the MCp box associated with one of the branches and enter a new MCp value as required

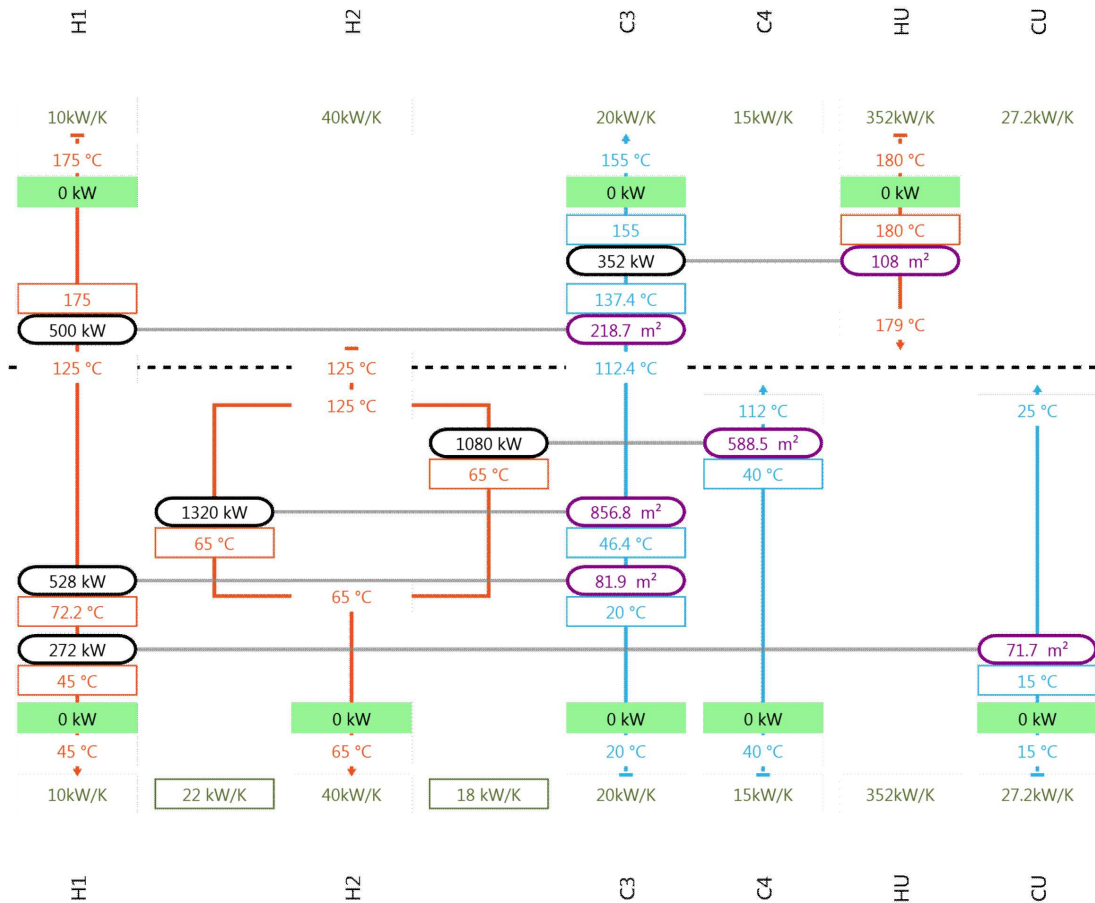

Fig. 12.4: HEN Grid With a Stream Merge

Note: Heat exchanger parts will be automatically added to each branch if a merge is made to a split that does not contain any manually added heat exchanger parts.

12.5 Analyzing Results

There are several graphical objects that can be used to analyze the results of a HEN grid design. The first is the HEN Table. This table displays upon initialization the Targeting Result data. The data is conveniently broken out into energy recovery values and utility values. As heat exchangers are added to the HEN grid then the design values are automatically added to the Design row in the table. This provides a convenient layout for comparing the design with targets in helping determine if the design is appropriate or not. Fig. 12.5 shows the completed result for the HEN design given previously in Fig. 12.3 and shows how close the target and design values are.

	Energy Recovery [kW]	Energy Recovery No. of Units	Energy Recovery Area [m ²]	Energy Recovery Investment Cost [CHF]	Util No. of Units	Util Area [m ²]	Util Investment Cost [CHF]
Design	3,428	4	1,746	997,512	2	168	163,061
Target	3,428	4	1,476	933,625	2	169	165,290

Fig. 12.5: HEN Table for Completed HEN Design

A second method of analyzing results is to use the HEX table (see Fig. 12.6). On this table is displayed the specific information for each placed HEX on the HEN Grid. The information includes the hot and cold streams properties and well as the HEX area, LMTD, k-value, cost, profitability and type selected. This data grid conveniently allows the analysis and comparison of each exchanger with the others.

How to Open the HEX Table:

1. Create a **MER HEN Grid**
2. Add an **Heat Exchanger**
3. Select the line joining the two heat exchanger part (Note: the line should be highlighted in black)
4. Double click the black highlighted line to open the HEX Table.

Finally, the HEX can easily be used to calculate the total real cost of the design by adding up the cost column values. This can be simply accomplished by copy and paste of data grid information into a spread sheet program such Microsoft Excel.

The individual HEXs are calculated by default assuming counter current heat exchange. However, it is possible to change the form factor used in the UA

Name	Heat Load [kW]	Hot Stream	Hot TIn [°C]	Hot TOut [°C]	Hot Mass Flow [kg/s]	Hot Cp [kJ/(kg*K)]	Hot MCp [kW/K]	Cold Stream	Cold TIn [°C]	Cold TOut [°C]	Cold Mass Flow [kg/s]	Cold Cp [kJ/(kg*K)]	Cold MCp [kW/K]	LMTD [°C]	Area [m²]	Cost [CHF]	HEX Type
H1 - C3	500	H1	175.00	125.00	1.00	10.00	10.00	C3	112.40	137.40	1.00	20.00	20.00	22.87	219	162,077	Counter Current
HU - C3	352	HU	180.00	179.00	0.01	30,000.00	352.00	C3	137.40	155.00	1.00	20.00	20.00	32.6	108	98,210	Counter Current
H2 - C4	1,080	H2	125.00	65.00	0.45	40.00	18.00	C4	40.00	112.00	1.00	15.00	15.00	18.35	589	327,356	Counter Current
H2 - C3	1,320	H2	125.00	65.00	0.55	40.00	22.00	C3	46.40	112.40	1.00	20.00	20.00	15.41	857	427,401	Counter Current
H1 - C3	528	H1	125.00	72.20	1.00	10.00	10.00	C3	20.00	46.40	1.00	20.00	20.00	64.5	82	80,678	Counter Current
H1 - CU	272	H1	72.20	45.00	1.00	10.00	10.00	CU	10.00	15.00	18.13	3.00	54.40	45.19	60	64,851	Counter Current

Fig. 12.6: HEX Table for Complete HEN Design

calculation to better represent a non-ideal situation in a real plant setting. Fig. 12.7 shows the options available for changing the parameters that affect the area and cost calculation of the individual heat exchanger. The film heat transfer coefficient (α) values are initialized from the stream table; however, they can be overwritten in the Heat Transfer Coefficient boxes. The same is true for the Heat Exchanger Cost parameters. Finally the calculated form factor correlations are derived from [11].

Operating Cases

OC 1 (0,7000)

Alphas

Heat Transfer Coefficient

Hot Seg.	Alpha	Cold Seg.	Alpha
1	200	1	200

Heat Exchanger Sizing

	F T	Cost
<input checked="" type="radio"/> Counter Current	1.000	162077
<input type="radio"/> Co-Current	-	TCross
<input type="radio"/> 1-2 Multi Pass	n. def.	n. def.
<input type="radio"/> 2-4 Multi Pass	0.889	176207
<input type="radio"/> Single Pass Cross Flow	0.676	214005
<input type="radio"/> Two Pass Cross Flow D.	n. def.	n. def.
<input type="radio"/> Two Pass Cross Flow R.	0.917	172356
<input type="radio"/> Form Factor	<input type="text" value="1"/>	162077

Heat Exchanger Cost

a CHF m

Cb CHF Qb m²

Fig. 12.7: HEN Sizing Options Dialog

12.6 HEN Design Support Tools

Two tools presently exist to support the analysis of heat exchanger networks and heat exchangers. The first is the Driving Force Plot (see Fig. 12.8).



Fig. 12.8: Enthalpy versus Temperature Plot and Driving Force Plot

This graphic is useful for assessing how well a particular heat exchanger approximates the vertical heat transfer model. The plot is created by calculating the differences in terminal temperatures of a counter-current heat exchanger versus the Driving Force Plot derived from the composite curve. The driving force plot is simply the temperature difference at the inflection points of the composite curve versus the cold temperature at the same point. The application and analysis of the driving force plot is reviewed in [1].

The second support tool is the Enthalpy versus Temperature Plot (HT Plot - see Fig. 12.8). This plot provides an effective means of checking the driving force of the selected heat exchanger relative to the given ΔT_{min} . This plot is very effective at quickly visualizing the driving forces within a heat exchanger, in particular the LMTD which has a significant impact on the required area. In addition, an internal heat exchanger pinch can be identified if multiple segments are used that result in a point within the heat exchanger where the ΔT_{min} occurs (and not at the end of the exchanger).

Given that the HEN grids can become quite large for stream populations greater than ca. 15 streams, the user can zoom on the HEN grid to focus on specific regions of the design. This is done by first positioning the cursor over the region to focus on and then using the mouse wheel to zoom in on this region.

The order of the streams in the HEN Grid are initialized directly from the order of the streams in the working stream table. The order of the streams in the working stream table can be simply changed before adding the HEN by selecting Alt + up/down arrow keys (same as for the process stream table itself). **However, the order of the streams on the HEN grid itself can be shifted directly by clicking on the name of a stream and dragging left or right.**

Another effective functionality to help in building a HEN design is the ability to add rows within the middle of the HEN grid before or after previously placed HEXs. This action prevents the overlap of HEXs on the same row and can be done by moving the cursor over the HEN grid to the location where a new row should be inserted. A **light grey bar** is shown to indicate a row can be inserted. Simply clicking at this location inserts the new row.

Finally, **detailed stream information** can be viewed directly on the HEN grid by positioning the mouse cursor directly over the blue or red line representing either the cold or hot stream. A tooltip is automatically displayed to show the stream name and the specific segment data such as T_{in} , T_{out} , CP and total enthalpy change.

Note: The Area-Temperature tool does not presently support segmented streams. Also when T_{in} T_{out} is set on the same stream then a simple iteration algorithm is used to get the correct LMTD for the given area and duty.

Exporting Targeting Information for Multiple OCs/TSs HEN Design:

For **Separate Design** target results, a feature is available to allow the exporting of the area matrices internally calculated for each multiple operating case (OC) or batch time slice (TS).

To Export Area Matrices:

1. Create a Target Result (see section 7).
2. Right click on the node of the created Separate Design Target Result and select **Export Area Match Matrices**.
3. On the Export Area Match-Matrices dialog select the OC/TS of interest.
4. Set the starting and ending ΔT_{min} values and step size to be used in creating the set of Area Match-Matrices.

5. Select **Export** to generate the matrices.
6. Save the generated csv file to an appropriate location.

For **Combined Supertargeting** target results, it is possible to export the internally calculated **Conventional Design matrices**. This includes the following:

- Candidate Match Matrix (in conventional design only one match (called a candidate match) can be re-used on each process stream. This matrix is results from the conventional design supertargeting LP optimization and highlights the matches that must be placed to reach the targets [16] and [17])
- Maximum Area Matrix (per Operating Case or Time Slice the maximum area that can be installed between each possible match between an equipment with a hot stream and an equipment with a cold stream)
- Pinch Match Matrix (describes all the possible matches at the pinch and merged together for all OCs or TSs)

More information is given in Appendix A.9.

To Export Conventional Design Matrices:

1. Create a Combined Supertargeting Target Result (see section 8).
2. Right click on the node of the created Target Result and select **Export Conventional Design Matrices**.
3. Select either i. To Clipboard or ii. To *.csv.
4. Save the generated csv file to an appropriate location.
5. Either paste the data directly into a calculation program directly (e.g. MS Excel or Google Sheets) or open the *.csv directly.

Multiple OC/TS HEN Design Support Tools:

The general strategy of HEN design for multiple OCs or TSs is based on the pinch design method used in creating the HEN. However, given the goal of reusing heat exchangers the method is extended to handle this reuse. The

method again starts first where the problem is most constrained at the pinch (design philosophy: do the most difficult task first). But priority is given to common pinch matches that reuse HEXs otherwise, if placed later, there is less scope for optimising the use of area because of HEN structural constraints. For these selected key matches vertical heat transfer is used for their design. However, for the remaining non-key matches criss-cross heat transfer may have to be used to maximize the area reuse. The result is several of these non-key HEXs could violate the ΔT_{min} and may even extend from one side of the pinch to the other. Nevertheless, minimising total cost by minimising the number of units (i.e. tick-off matches) is first priority, while minimisation of area is only second priority (i.e. under the normal assumption that the number of HEX matches has a larger effect on investment cost than the area).

Two main HEN design support tools are available that together with the area matrices and conventional design matrices noted above can be used to help the user design a flexible overall HEN. The details of how to do such design is in Appendix A.9.

To help easily and quickly identify common matches in different OCs or TS, the Mini-map tool is available. It is shown on the top edge of the HEN grid whenever multiple OCs or TSs are present (see Fig. 12.9)

The map simply shows the connections between pieces of equipment (typically a pipe with a stream flowing in it, but could be a batch reactor). The first match between the same two pieces of equipment are shown as a dashed line. When a second match between the same two pieces of equipment is added to another OC or TS then the lines are shown solid. The match with largest area is shown in bold to easily identify the key match. Fig. 12.10 show TS 2 to compare with the TS 1 shown in Fig. 12.9.

To be able to calculate the effects of criss-cross heat transfer the Area-Temperature support tool is available. It allows the quick calculation of different combinations of temperature for a given area.

How to Use the Area-Temperature Tool:

1. Create a Combined Supertargeting Target Result (see section 8) or Batch Process Target Result
2. Right click on the node of the created Target Result and select **Add HEN...**
-> **Add MER HEN**
3. Left click on a hot stream to **add a stream part**

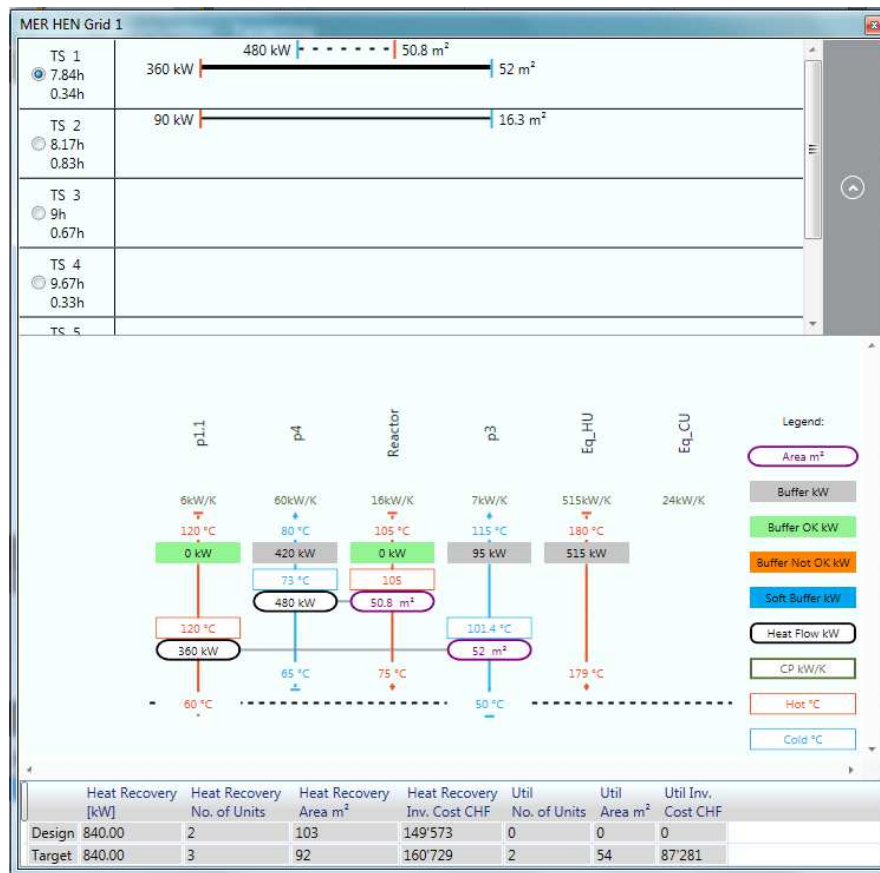

Fig. 12.9: Heat exchanger Mini-map Tool displaying at top edge of HEN grid when multiple OCs or TSs exist. TS1 is shown with the largest area at 52 m² between equipment p1.1 and p3. A dashed line is shown between equipment p4 and Reactor as it is the only HEX in all TSs.

- Left click on a cold stream to add a stream part (Note: Ensure the MC_p rule based on the Pinch Design Method is maintained - MC_p of a stream going in a direction away from the pinch is greater than the MC_p of a stream going towards the pinch)
- Left click on one of the newly added stream parts and **hold and drag** to the other stream part (ensure both stream parts are on the same vertical row as diagonal placement is not allowed for cross pinch heat transfer)
- Release the left mouse button to create the match.
- Double click in the HEX duty box to **tick-off** the entire duty of one of the streams (Note: According to the Pinch Design Method, it is recommended to always use the entire duty of one of the streams in a match)

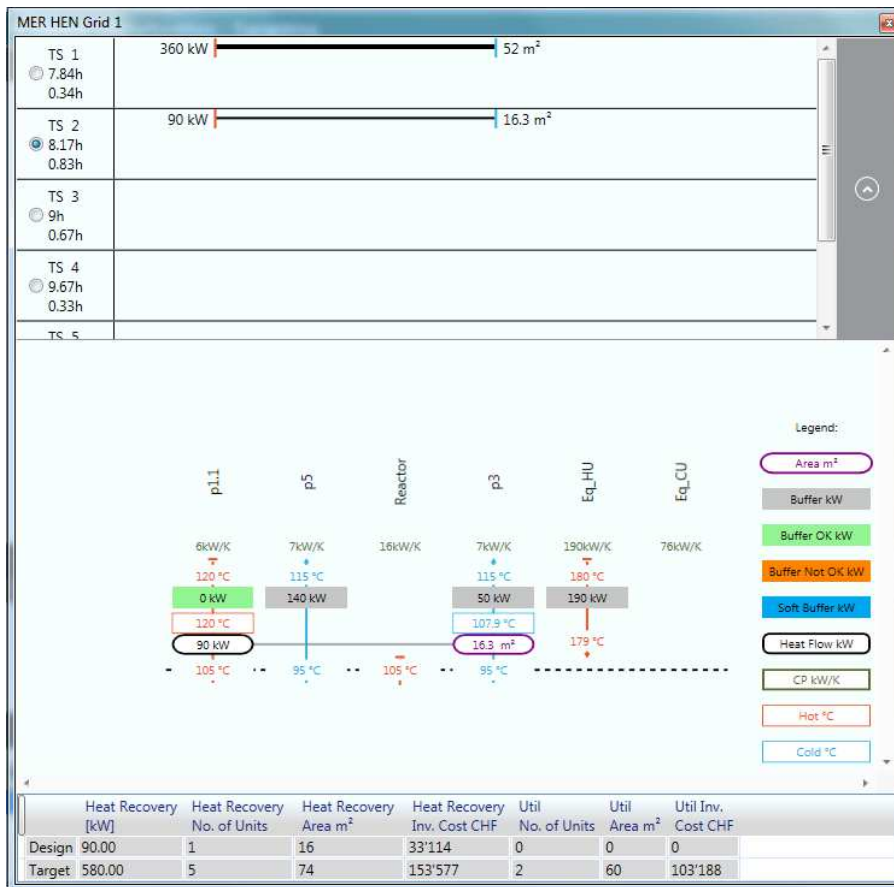

Fig. 12.10: Heat exchanger Mini-map Tool displaying at top edge of HEN grid for TS 2 illustrating the easy comparison with TS 1 and identification of key HEX with largest area.

8. Right click on either the HEX stream parts and select Display **Area-Temperature Tool** (The dialog as shown in Fig. 12.11 is shown)
9. Select two of the four temperature check boxes to force calculation of the other two temperatures as required
10. Enter an area as required to see the effects of reusing a greater value (e.g. from the key HEX in another OC or TS)

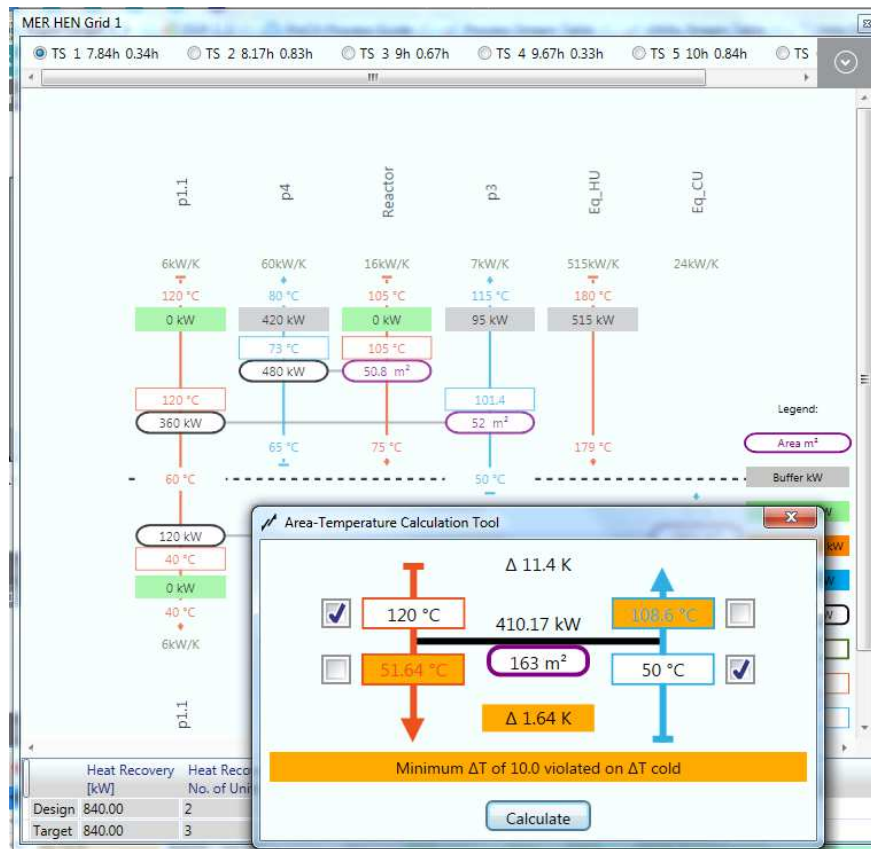

Fig. 12.11: Area-Temperature Tool showing the effect of using a larger area

Note: The Area-Temperature Tool is a separate dialog for checking the effects of HEX area on the terminal temperatures. The results are only shown in the dialog and not reflected in the original HEN grid.

Chapter 13

Menu Items, Keyboard Shortcuts and the Workbench

13.1 Menus Items and Keyboard Shortcuts

PinCH includes many menu items to allow the user to do actions such as manage the project and its settings, customize the layout, import and export data and access help online information. In addition, the PinCH menus display equivalent keyboard shortcuts next to many of the menu commands, so the user can execute commands directly from the keyboard.

It should be noted that the menu items are not always available and depend on the state of the program or action being executed. An example is the Save menu item as it will be disabled when no changes have been made to a project. If a change has been made then this menu item is enabled and the program title is appended with “*” to indicate that changes have been made and must be saved or they will be lost. Upon closing you will be asked to confirm if you would like to save your changes.

The following tables list the commands presently available in PinCH and any associated keyboard shortcut that exists.

Tab. 13.1: File Menu Items

File Menu Items	Keyboard Shortcut
New Project	Ctrl + N
Open Project	Ctrl + O
Close Project	
Save Project	Ctrl + S
Save Project As...	
Import Stream Table	
Export Stream Table	
Settings	
Exit	

Tab. 13.2: Edit Menu Items

Edit Menu Items	Keyboard Shortcut
Undo	Ctrl + Z
Redo	Ctrl + Y
Copy	Ctrl + C
Paste	Ctrl + V

Tab. 13.3: View Menu Items

View Menu Items	Keyboard Shortcut
Save Custom Layout	
Load Custom Layout	
Restore Initial Layout	
Process Stream Table	
Utility Stream Table	
Project Explorer	
Target Explorer	
Properties	
Help	
Results Output	

Tab. 13.4: Help Menu Items

Help Menu Items	Keyboard Shortcut
PinCH Process Survey	
PinCH Home	
Help	F1
About	

Note: PinCH 2.0 can be opened with PinCH 3.2 for backward compatibility. PinCH will automatically convert a PinCH 2.0 file to the new compressed forward and save the file with the same name but with the .PinCH extension. the original .xml file is still available. However, **files created in the PinCH 3.2 format cannot be read by PinCH 2.0.**

The function of most of the menu items can be understood from the menu item name. Several of the more important menu items are listed and explained next.

- Settings

After selecting the Settings menu item a new settings dialog is displayed in the details docking position in the center of the workbench. This dialog allows the user to change the display of the help information, change the engineering unit set and change the currency. The engineering unit sets are the combinations of either kW/kWh, MW/MWh and kW/MWh (the default). The currency is limited to CHF (the default), USD and Euro whereby the a conversion rate base on CHF must be supplied to calculate USD or Euro accordingly.

To configure the project settings:

1. Select the menu item **File** then **Settings**
2. The **User Interface tab** can be selected to choose different user interface display types to be shown or hidden.
3. The **Units tab** to change to different engineering unit sets to be shown in the results.
4. The **Currencies tab** allows different currencies to be selected to be shown in the results (e.g. Euro oder US Dollar). If you wish to use a different currency as CHF, then the currency conversion rate must be given.

5. The **General tab** contain a collection of defaults used for calculations (e.g. ambient temperature used in calculating the Carnot factor).
6. The **Licensing tab** allows activation and management of the software license. Most importantly, on this tab **the name of the licensing server** (in the case of using a network license) can be simply entered and activated. In addition, time period licenses can be requested for an update by selecting to open the **Trial/Activation** dialog and then using the **Request License Update** button (note: this functionality is not applicable for the trial version of the software). See **PinCH 3.2 Installation User Manual.pdf** for more information.

It is recommended to change all the settings before beginning the pinch analysis.

Note: The unit sets are in almost all cases only for changing the display values shown in data grids or on charts. Heat flow values are always readonly in kW. However, in the indirect heat recovery target result the energy value can be entered in either kWh or MWh, as well as the currencies can be entered in chosen currency set.

- Import and Export Data

Several options exist to import or export data from PinCH. The menu item **Import Stream Table** and **Export Stream Table** can be used to easily transfer data from Excel (see section 4.7 for an example). In addition, each data grid used for displaying results can be copied and pasted directly into applications such as Excel or Word.

Additional features are available to allow the exporting of key targeting information. For separate design targeting results, the area matrices internally calculated for each multiple operating case (OC) or batch time slice (TS) can be exported. In addition, for Conventional Design supertargeting, the Candidate Match Matrix, PinCH Match Matrix and Maximum Area Matrices can be easily exported to external programs such as MS Excel or Google Sheets. Please see section 12.6 for more information.

13.2 Keyboard Shortcuts - Stream Table

Several keyboard shortcuts are available within PinCH to enable commands to be executed when working with the stream table.

How to Change the Order of Streams:

1. Select a stream in the stream table.
2. Press and hold down the Alt key.
3. Select the Up or Down arrow key to move the stream to a different position in the table.

Note: The order of the stream in the working stream table can also be re-ordered independently from the main stream table. Conveniently, the order of the streams in the working stream table are used to initialize the stream order of the HEN grid when first created. The user can control the HEN grid stream order by placing at the top of the working stream table the streams to be placed starting on the left side in the HEN grid as initialization. **However, the streams can then be easily be reordered directly on the HEN Grid by clicking on the stream name and dragging left or right!**

How to Assign Multiple Rows to a Process:

In section 6.3 it was shown how to assign a single stream to a process. The following illustrates how to assign multiple streams.

1. Press and hold the Ctrl key.
2. Select specific rows in the Stream Table to highlight.
3. Assign the selected streams to the working stream table.

Note: Consecutive rows of streams can be selected by pressing and holding the Shift key and then selecting a stream at another location in the stream table. All the streams between the two selected streams will be highlighted and can be assigned to the working streams table.

13.3 Keyboard Shortcuts - HEN Grid

Several keyboard shortcuts are available within PinCH to enable commands to be executed when working with the HEN Grid.

How to Insert an Empty Row in the HEN Grid:

A HEN Grid design is built starting from the pinch temperature and working away from the pinch. To give the flexibility to place heat exchangers (HEX) at specific vertical locations (e.g. to avoid overlap of HEXs) an empty row in the HEN Grid can be inserted at any vertical position.

1. Create a HEN Grid (see section 12.2).
2. Position the mouse cursor over the HEN Grid at the vertical location you wish to add a new row for a HEX (note: a light grey horizontal line will be shown).
3. Click the left mouse button.
4. An empty row will be placed immediately at the selected location.

How to Zoom and Pan on the HEN Grid: (ctrl and mouse wheel)

1. Open a previously created HEN Grid.
2. Ensure the mouse cursor is positioned over the HEN grid.
3. Zoom in or out by using a mouse wheel or equivalent.
4. Press the Ctrl button while zooming will pan directly to a specific point on the HEN Grid.

13.4 Workbench

13.4.1 Dockable Windows

The workbench is composed of dockable windows that can be moved and repositioned to any docking position on the workbench. In addition, the dockable window can be left in a floating position to be displayed , for example,

on a second computer screen. Both of these options allow easy comparison of results or data that has been entered (i.e. Chap. 7.4 Fig. 7.3).

However, the situation may arise whereby you want to automatically return to a simpler default layout of the windows. As shown above for the View commands (Tab. 13.3) it is possible to restore the original default layout (i.e. Restore Initial Layout menu) used when first installing PinCH. In addition you can restore a custom layout that you can save at any time that maintains your desired dockable window arrangement (i.e. Save Customer Layout/Load Customer Layout).

13.4.2 Properties Window

On the properties window the user can see specific data related to any object selected in the PinCH user interface. For example, selecting a stream in the stream table will display in the properties window the stream name and the equipment that has been assigned. These values can be changed as needed. Other important objects that display data in the Properties Window includes the Equipment and the individual OC/TS Target Result, ISSP, HEN Grid and HESN Schema.

13.4.3 Explorer Nodes

In the Project and Target Explorer, data is presented in a tree node structure. All automatically added nodes based on a command (e.g. Add Target Result) use a standardized numerical naming process. These names can be changed at any time by pressing F2 when highlighted. In addition, these automatically added nodes can be conveniently shifted by drag and drop using the mouse. This gives the user the ability to reorder the nodes as needed.

Chapter 14

List of Symbols And Acronyms

14.1 Symbols

A	Heat exchanger surface area	m^2
A_{min}	Minimum area target for an entire network	m^2
$A_{min,L}$	Minimum area contribution of exchanger specification	m^2
a	Fixed investment cost component	CHF
C	Investment Cost	CHF
C_b	Base Cost	CHF
C_p	Specific heat capacity (at constant pressure)	$kJ/kg\ K$
CP	Heat capacity flow (at constant pressure)	kW/K
fm	Materials of construction factor	[-]
fp	Pressure factor	[-]
ft	Temperature factor	[-]
fi	Installation faction	[-]
H	Heat/Energy	kWh
$\Delta\dot{H}$	Heat flow/Enthalpy flow	kW
Index	Cost Index (e.g. default values CE Plant Cost Index)	[-]
L	Exchanger specification	[-]
Ni	Number of enthalpy intervals	[-]
NE	Number of different exchanger specification	[-]
NHL	Number of hot streams with exchanger specification L	[-]
NCL	Number of cold streams with exchanger specification L	[-]
Q_b	ECU cost base quantity for an ECU	$kW, kg/s$
$Q(i,j)$	Heat rate between hot stream i and cold stream j	W
ΔT	Minimum temperature difference	K
X	Humidity ratio	$kg\ H_2O / kg\ Dry\ Air$

x_0, x_1	Quality (bubble point, dew point)	[-]
α	Film heat transfer coefficient	W/m ² K
h_F	Specific enthalpy waste heat vapour stream	kJ/kg
h_{mix}	Specific enthalpy mixture	kJ/kg
h_T	Specific enthalpy <i>steam</i> stream (Treibstoff)	kJ/kg
i	Hot stream	[-]
j	Cold stream	[-]
k	Enthalpy interval	[-]
k	Overall heat transfer coefficient	W/m ² K
m_T	Mass flow <i>steam</i> stream (Treibstoff)	kg/s
m_F	Mass flow waste heat vapour stream (Forderstrom)	kg/s
ξ_{Tr}	Entrainment (reversible)	[-]
ξ_T	Entrainment (irreversible)	[-]
η_D	Diffusor efficiency	[-]
η_E	Expander efficiency	[-]
ϕ	Relative humidity	[%]

14.2 Acronyms

BCC	Balanced Composite Curve
BGCC	Balanced Grand Composite Curve
CC	Composite Curve
csv	Comma Separated Values format
CU	Cold Utility
DHR	Direct Heat Recovery
ECU	Energy Conversion Unit
el	Electrical
EM	E-Module
ETA	Energy Target Analysis
GCC	Grand Composite Curve
HVAC	Heating Ventilation Air Conditioning
HEX	Heat Exchanger
HEN	Heat Exchanger Network
HP	Heat Pump
HS	Heat Storage
HU	Hot Utility
IDE	Integrated Development Environment
IHR	Indirect Heat Recovery
IL	Intermediate Loop
ISSP (GCC)	Indirect Source Sink Profile (GCC Based)
ISSP (Stream)	Indirect Source Sink Profile (Stream Based)
max	Maximum
mech	Mechanical
min	Minimum
MER	Minimum Energy Requirement, Maximum Energy Recovery
MOC	Multiple Operating Cases
MVR	Mechanical Vapour Recompression
P	Power
PA	Pinch Analysis
PI	Process Integration
png	Portable Network Graphics file
Split GCC	Split Grand Composite Curve
TAM	Time Average Model
TS	Time Slice
TSM	Time Slice Model
TVR	Thermal Vapour Recompression
VSU	Volume Storage Unit (i.e. Temperature level in stratified tank)

Chapter 15

Bibliography

1. Shenoy S., (1995), "Heat Exchanger Network Synthesis - Process Optimization by Energy and Resource Analysis", Gulf Professional Publishing.
2. Morand R., et al, (2006), Prozessintegration Mit Der Pinch-Methode-Handbuch Zum BFE Einführungskurs, Bundesamt für Energie BFE, [online handbuch].
3. Wellig B., et al, (2008), "LOREF: Optimierung des Lamellenluftkühlers/Verdampfers con Luft/Wasser-Wärmepumpen Teil 2: Mathematisch-physikalische Simulation des lamellenluftkühlers mit Kondensat- und Frostbildung", Schlussbericht, BFE.
4. Lee B.Y., Kesler M.G., (1975), A generalized thermodynamic correlation based on three-parameter corresponding states, AIChE Journal, 21, 3, 510-527.
5. "User Guide on Process Integration for the Efficient Use of Energy", The Institution of Chemical Engineers, Rugby, England 1982.
6. Linnhoff B., Turner J.A., Chem.Eng. Nov. 2, (1981), p. 52.
7. Linnhoff B., Vredefeld D., Chem.Eng. Progress (1984)7, S. 33-40.
8. Linnhoff B., Kotjabasakis E., Chem.Eng. Res.Des. Vol. 64 (1986)5, p.197-211.
9. Linnhoff B., (1993), Pinch analysis-a state-of-the-art review. Trans. IChemE, 71, Part A.

10. Kemp I., (2007), "Pinch Analysis and Process Integration - A User Guide on Process Integration for the Efficient Use of Energy" (second edition), Butterworth-Heinemann (Elsevier).
11. Bowman R.A., Mueller A.C., and Nagle W.M., (1940), "Mean Temperature Difference in Design", Transactions of the A.S.M.E., 62, 283-294.
12. Jegede F.O., and Polley G.T., (1992), "Capital cost target for networks with non-uniform heat exchanger specifications", Comp. and Chem. Eng., 16(5).
13. Bosnjakovic F., (1988), "Technische Thermodynamik, Teil 1" 7. Auflage, Steinkopff Verlag, Darmstadt.
14. Smith R., (2005), "Chemical Process Design and Integration", John Wiley and Sons, England.
15. Arbeitsgemeinschaft für Sparsamen und Umweltfreundlichen Energieverbrauch ASUE, (2011), "BHKW - Kenndaten 2011", energieDRUCK.
16. Jones P.S., (1991), "Targeting and design of heat exchanger networks under multiple base case operation", PhD Thesis, University of Manchester Institute of Science and Technology (UMIST), U.K.
17. Krummenacher P., (2001), "Contribution To The Heat Integration Of Batch Processes (With or Without Heat Storage)", Thèse No. 2480, École Polytechnique Fédérale de Lausanne, Switzerland.
18. Bell, I, et al., (2014) "Pure and Pseudo-pure Fluid Thermophysical Property Evaluation and the Open-Source Thermophysical Property Library CoolProp", Ind. Eng. Chem., 53 (6), pp. 2498-2508.
19. Olsen D, Abdelouadoud Y, Wellig B, Krummenacher P., (2016) "Systematic thermal energy storage integration in industry using pinch analysis" 29th International Conference on Efficiency, Cost, Optimization, Simulation and Environmental Impact of Energy Systems (ECOS), Slovenia.
20. Olsen D., Liem L., Abdelouadoud Y., Wellig B., (2017) "Thermal Energy Storage Integration Based on Pinch Analysis - Methodology and Application". Chemie Ingenieur Technik, Vol. 89, Issue 5.
21. Brunner F., Krummenacher P., Wellig B., (2015) "Einführung in die Pinch-Methode; Handbuch für die Analyse von kontinuierlichen Prozessen und Batch-Prozessen" Bundesamt für Energie BFE, Switzerland.

Appendix A

Appendix

A.1 Area And Number Of Units

The internal calculations used for targeting are based on the approach published in [12]. This approach extends the traditional Uniform Bath formula to give the flexibility to apply different heat exchanger cost formulas for a given stream. In PinCH different cost formulas can be defined for either hot or cold utility exchangers or for process-process heat exchangers. In order to accomplish this differentiation in heat exchanger type, the area calculation is changed to provide a matchwise area distribution. The reader is encouraged to read the original paper for details for more information on the derivation of the following formula.

$$A_{min L} = \sum_{k=1}^{N_i} \frac{1}{LMTD, k} \sum_{i=1}^{NHL} \sum_{j=1}^{NCL} Q_{(i,j)k,L} \left(\frac{1}{\alpha_{i,j}} + \frac{1}{\alpha_{j,i}} \right)$$

Given an area distribution for each heat exchanger match, it becomes imperative to establish the number of units that can be attributed to each type of heat exchanger specification. Like the area distribution, it is insufficient to assume an equal distribution as done in early targeting calculations; therefore, a unit distribution must be calculated. The chosen method for calculating a unit distribution is to start with the known number of matches above and below the pinch temperature assuming the “spaghetti” design vertical heat transfer model. Next, for each heat exchanger specification the number of matches above and below the process pinch can also be determined. These values can then be used to weight the number of units calculated in a standard manner to provide the number of units for a specific exchanger specification as shown in the following equation.

$$N_{unit, L} = (Na - 1) \frac{Va, L}{Va} + (Nb - 1) \frac{Vb, L}{Vb}$$

A.2 Heat Pump Energy Conversion Unit

The heat pump energy conversion unit model provides a simplified representation of a heat pump with an internal regenerator. This model provides the heat integration streams representing the heat flow into the evaporator and out of the condenser. These process requirement streams are automatically included into the stream population for a particular targeting result operating case or time slice.

The required heat loads and temperatures for both the condenser and the evaporator are ideally sized using the grand composite curve for the original targeting result operating case or time slice and must be properly placed relative to the pinch. The user must supply the evaporator and condenser temperature as well as the power in either the condenser or the evaporator. Once this information is set the thermodynamic cycle can be solved.

The key calculation for the heat pump thermodynamic cycle is the isentropic calculation across the compressor. An isentropic efficiency entered on the heat pump dialog is used to simply calculate the actual enthalpy requirement across the compressor. The calculation uses an internal fluid phase flash calculation based on the equation of state in [4] to calculate the specific enthalpy exiting the compressor. Once this state is known an energy balance around the regenerator can be solved. The key assumptions in this balance equation are bubble point conditions at the outlet of the condenser, dew point conditions at the outlet of the evaporator and 5 K superheating over of the regenerator. The necessary flash calculations based on [4] are used to determine the required state data. The schemas of the heat pump as well as the thermal cycle illustrating the thermodynamic cycle are shown in the following figures.

Note: The Mechanical Vapour Recompression (MVR) ECU uses the same compressor calculation as the heat pump.

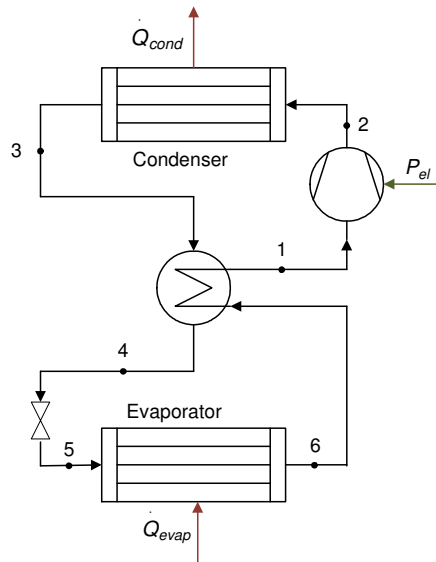

Fig. A.1: Heat Pump Energy Conversion Unit with Regenerator

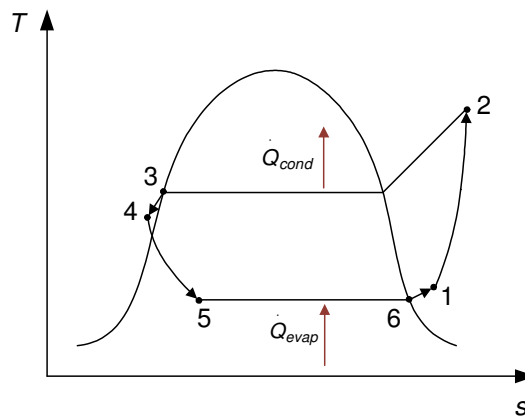

Fig. A.2: T, s -diagram of Heat Pump Cycle

A.3 Internal Combustion Engine Energy Conversion Unit

The Engine calculation is used for assessing the energy integration effects of including a combined heat and power unit (CHP). The engine ECU incorporates a standard combustion calculation as well as heat load ratios. The result is the creation of three separate streams that are used as additional process streams and are automatically included in the stream population on the level of the Target Result. They are as follows:

1. Water flow stream
2. Engine oil stream
3. Exhaust Gas stream

The first two streams are calculated using a simple engine heat load calculation based on the factors already displayed on the engine dialog. These factors are based on standard ratios of waste heat energy to mechanical power generated. These ratios can be edited as needed.

The displayed Exhaust Gas heat flow does not use a load factor. The actual amount of exhaust gas waste heat is calculated internally based on a standard combustion calculation as listed in the following steps:

1. An air stream at 50% humidity and a temperature ΔT 15°C is assumed to be mixed and burned using a fuel with the given composition as entered on the Engine Dialog.
2. The mole fractions of N₂, O₂ and H₂O in the air stream are calculated.
3. The ratio for moles of Air/moles of fuel and moles of exhaust air/moles of fuel are calculated based on the stoichiometric quantities and the given air to fuel ratio.
4. The moles of O₂, N₂, CO₂, H₂O / mole of fuel are calculated.
5. The mole fractions of N₂, O₂, CO₂ and H₂O in exhaust gas are calculated.
6. The mass fractions N₂, O₂, CO₂ and H₂O in exhaust gas can then be calculated.

7. The mass fractions N_2 , O_2 , CO_2 and H_2O in exhaust gas on a dry basis are calculated
8. The dry basis mass fractions are then used to calculate enthalpies at inlet and outlet conditions by simply summing the enthalpy contributions of each exhaust gas component over the given cooling temperature range. The water enthalpy contribution is handled in a similar manner with the addition of the heat of condensation.
9. Given the inlet and outlet enthalpy data calculated in step 8, the stream segments are then calculated assuming an average C_p per segment temperature range based on a **dry basis** for the combustion gas mass flow.

Note: The mass flow rate of the combustion gas is calculated and displayed on a **dry basis** as is the norm in engineering calculations involving humid air streams such as combustion gas.

A.4 Mechanical Vapour Recompression Energy Conversion Unit

The mechanical vapour recompression energy conversion unit operates with the similar goal as the thermal vapour recompression unit. However, this unit utilizes a compressor to achieve the temperature lift necessary to reach the required condensation temperature. The MVR is also in principle a heat pump, yet is an open system that takes an existing stream and upgrades it to a higher pressure and condensation temperature. The following figure illustrates the operation of an MVR.

Note: The selection of the water vapour stream is limited to the fluid **R718 (water)** based on the equation of state given in [4].

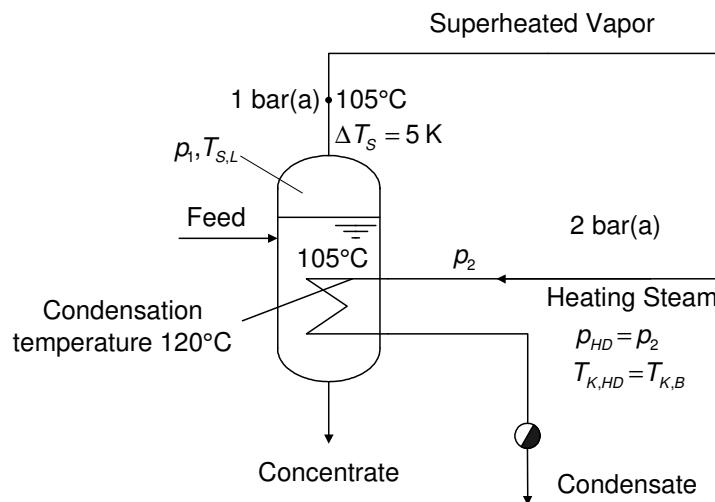

Fig. A.3: Simple Evaporator Unit

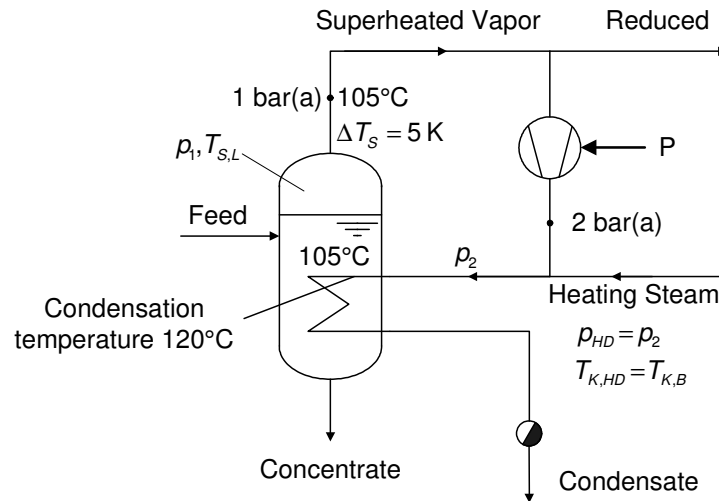

Fig. A.4: Simple Evaporator Unit with a Mechanical Vapour Recompression (MVR) Energy Conversion Unit

The stream selected is limited to a water vapour stream that is subcooled. The amount of this stream to upgrade is set in the MVR dialog allowing the same compressor calculation as listed in Appendix A.2 for the heat pump ECU to determine the state at the outlet of the compressor. The electrical power requirements, incorporating isentropic and drive efficiencies, can then be calculated and used in the cost calculation for the compressor.

A.5 Thermal Vapour Recompression Energy Conversion Unit

The thermal vapour recompression (TVR) energy conversion unit (ECU) operates with the similar goal as the mechanical vapour recompression unit. However, this unit utilizes medium to high pressure steam to achieve the temperature lift necessary to reach the required condensation temperature. The TVR is also in principle a heat pump, yet is an open system that takes an existing stream and upgrades it to a higher pressure and condensation temperature. The following figure illustrates the principle of a TVR.

Note: The selection of the water vapour stream is limited to the fluid **R718 (water)** based on the equation of state given in [4].

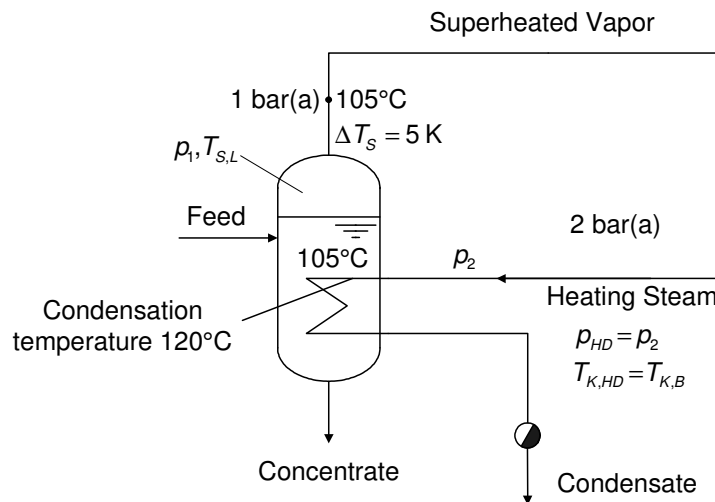

Fig. A.5: Simple Evaporator Unit

A.6 Organic Rankine Cycle Energy Conversion Unit

The basic Organic Rankine Cycle (ORC) works on a similar principle as the standard Rankine Cycle. The main difference being that the ORC uses an organic heat transfer medium and not water as the working medium. Therefore, the purpose of the ORC is to take heat as input, and convert it to a useful work output, in the form of shaft-work. The shaft-work can then be used to produce electricity.

An advantage of the ORC is that the organic working fluids have a lower boiling temperature at ambient pressure than water, i.e. the organic working fluids evaporate at lower temperature levels than water. This is important for pinch analysis as the ORC can take advantage of the lower temperature level excess heat under the pinch point, with the benefits of generating shaft-work and reducing the required cold utility. (Note: There also exists the possibility to remove heat from a pocket (in the GCC), but this is not discussed here.)

Table A.1 lists the organic fluids that are modeled in PinCH with some important characteristics. The critical temperature and pressure represent the upper bounds for sub-critical operating conditions.

Tab. A.1: ORG Organic Fluids Modeled in PinCH

Organic Fluid	Boiling Temperature* (°C)	Critical Temperature (°C)	Critical Pressure (bar(a))	Group**
R134a	-26.1	101.1	40.6	isentropic
R245ca	25.0	178.4	38.6	dry
R245fa	15.1	154.01	36.5	dry
n-Butane (R600)	-0.5	152.0	37.94	isentropic
Isobutane (R600a)	-11.7	134.7	36.4	isentropic
n-Pentane (R601)	36.1	196.6	33.7	dry
Ethanol	78.4	241.6	62.7	wet
Octamethyltrisiloxan (MDM)	152.5	290.9	14.2	dry
Toluene	110.6	318.6	41.3	dry

*Boiling temperature at normal conditions

**Group Explanation:

Isentropic	The dew-point curve of these organic fluids appears isentropically (i.e. vertical) in the T,s diagram
Dry	The dew-point curve of these organic fluids has a positive slope in the T,s diagram
Wet	The dew-point curve of these organic fluids has a negative slope in the T,s diagram

The two main variations of an ORC are the basic ORC, displayed in Figure A.7 (a), and the ORC with regeneration shown in Figure A.7 (b). Both the process flow diagram and the corresponding T,s diagram are shown for each variation.

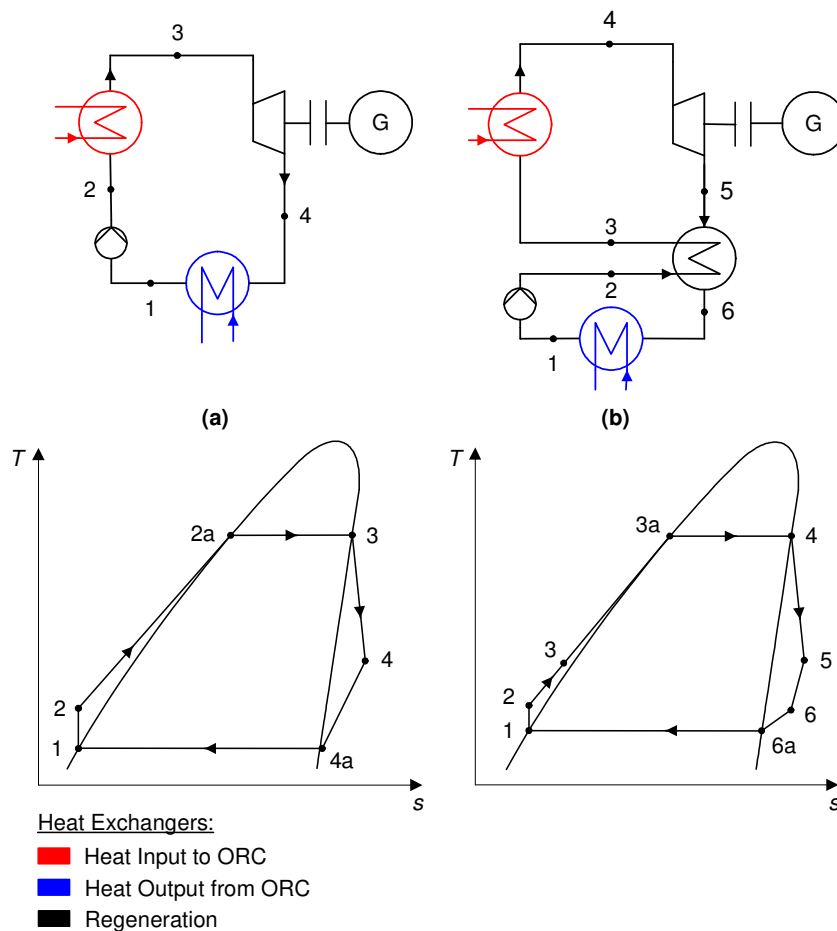

Fig. A.7: Basic (left) and Regenerative (right) ORCs and main streams.

The difference between the two variations is that the Regenerative ORC has an in-process heat exchanger for heat recovery. This has the effect of increasing the efficiency of the ORC by reducing the amount of required heat input over the evaporator most commonly used with dry organic fluids. The work produced by the turbine is the same for both cycles.

The part of the ORC that is of interest with respect to PinCH is the heat transfer between states 2 – 3 for the basic cycle and states 3 – 4 for the regenerative cycle, i.e. the heat input to the evaporator. However, the stream that will be modeled and using in PinCH target result is an assumed **intermediate loop (IL)** (yet very commonly used) to transfer heat from the process streams to the evaporator. The values defining the IL (heat flow input to evaporator, high (inlet) and low (return) temperatures of the IL) are entered by the user directly. These along with the condensation and evaporation temperatures allow the calculation of the remaining IL stream values and ORC thermodynamic state information for the ORC to be calculated directly. The calculations are for the ORC *without* the regenerator as only this type has been implemented in PinCH, i.e. states 1 - 4a in Fig. A.7a (a regenerative ORC is planned for the future).

Once all the required values are known and with the help of the Grand Composite Curve, the IL can be determined and displayed on the GCC to check for proper integration. It should be noted that the use of an IL decouples the investment cost of the ORC from the HEN grid area calculation allowing an ORC module cost to be used directly. Figure A.8 shows the placement of an IL and ORC evaporator and condenser streams relative to the GCC of the background process. The blue stream (IL on process side) is the key stream that will be modeled in PinCH and included in the target result and HEN design. All the other streams are also calculated internally but are independent from the process itself. Each has been shifted according to the process ΔT_{min} . The ability to set a separate ORC ΔT_{min} is not yet available.

Note: Presently, only the IL stream and evaporation stream are displayed on the GCC of the PinCH ORC ECU dialog.

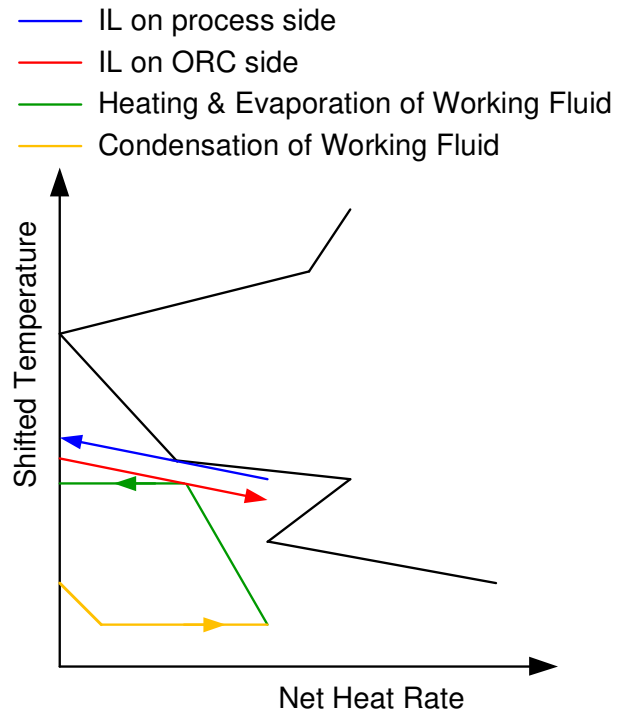

Fig. A.8: Placement of IL and ORC evaporator and condenser flows on the GCC of the background process. Each stream has been shifted based on the process DT_{min} .

A.7 Add-In Functions and Excel “What-If-Analysis” and “Solver” Tools

A.7.1 PinCH Add-In Functions

The three tables in this section list the currently available Add-In functions and the required inputs and calculated outputs. These functions act as an interface between PinCH and Excel. Table A.2 lists the different inputs and outputs of the functions, Table A.4 displays the available Steam Table Add-In functions and Table A.3 shows the Add-In functions available for Humid Air.

Note: It is imperative that close attention be paid to the units of the different inputs and outputs as the units are not displayed in Excel.

Tab. A.2: Input and Output Variables used in the Add-In Functions

Designation	Variable Name	Units
p	Pressure	bar(a)
t	Temperature	°C
x	Vapor Quality*	–
h	Specific Enthalpy	kJ/kg
s	Specific Entropy	kJ/kg/K
hl	Specific Enthalpy	kJ/kg <i>dry air</i>
Xw	Humidity Ratio	–
ts/tsat	Saturation Temperature**	°C
ps/psat	Saturation Pressure	bar(a)
phi	Relative Humidity	%
pl	Partial Pressure Air	bar(a)
Rho	Density Humid Air	kg/m ³

* Vapor fraction in the two phase region

** E.g. Dew point in °C at a given p [bar(a)] and X [g_{h2o}/kg *dry air*]

Tab. A.3: Humid Air Add-In Functions

To Be Calculated	Function Name	Input	Result
Specific Enthalpy Air (dry)	PinCH_HumidAir_hl_ptXw	p, t, Xw	hl
Saturation Temperature	PinCH_HumidAir_ts_pXw	p, Xw	ts
Saturation Pressure Water	PinCH_HumidAir_ps_pt	p, t	ps
Temperature	PinCH_HumidAir_t_phlXw	p, hl, Xw	t
Humidity Ratio	PinCH_HumidAir_Xw_ptphi	p, t, phi	Xw
Relative Humidity	PinCH_HumidAir_phi_ptXw	p, t, Xw	phi
Partial Pressure Air	PinCH_HumidAir_pl_ptXw	p, t, Xw	pl
Density Humid Air	PinCH_HumidAir_Rho_ptXw	p, t, Xw	Rho

Tab. A.4: Pure Fluid Table Add-In Functions Based on CoolProp Fluid Database

To Be Calculated	Function Name	Input	Result
Specific Heat Capacity	PinCH_PureFluid_cp_pt	p, t	cp
Specific Heat Capacity	PinCH_PureFluid_cp_px	p, x	cp
Specific Heat Capacity	PinCH_PureFluid_cp_tx	t, x	cp
Enthalpy	PinCH_PureFluid_h_pt	p, t	h
Enthalpy	PinCH_PureFluid_h_px	p, x	h
Enthalpy	PinCH_PureFluid_h_tx	t, x	h
Saturation Pressure	PinCH_PureFluid_psat_t	t	psat
Entropy	PinCH_PureFluid_s_ph	p, h	s
Temperature	PinCH_PureFluid_t_hs	h, s	t
Temperature	PinCH_PureFluid_t_ph	p, h	t
Saturation Temperature	PinCH_PureFluid_tsat_p	p	tsat
Quality	PinCH_PureFluid_x_hs	h, s	x

To have direct access to the standard CoolProp PropsSI function using the PinCH Addin, the following general function has been provided:

Tab. A.5: CoolProp Pure Fluid General Add-In Function

To Be Calculated	Function Name	Input	Result
Any Fluid Property	PinCH_CoolPropSI	<Prop1>, <Prop2>, <Fluid Name>	<Property>

This function wraps the standard PropsSI CoolProp function to allow easy and simple access to all pure fluid calculations. The function provides a convenient approach to calculate a desired property from almost any combination of two input property variables.

e.g. $\text{PinCH_CoolPropSI}("H";"P";30000;"T";350;"R744") = 551692.4 \text{ J/kg}$.

(Where P is in Pa and T is in K).

Please check the CoolProp Documentation for details about the different properties and their associated engineering units as well as the proper alias naming convention for each fluid (see www.coolprop.org).

Results for Wrong Input Values

Error Shown in Cell:	< <i>MaximumValue</i> >	Incorrect or Out of Range Input Value
Error Shown in Cell:	# <i>Wert</i> !	Incorrect number of parameters in macro

A.7.2 Excel “What-If-Analysis” and “Solver” Tools

In general, a thermal system can be defined by a given (determinable) number of input parameters. Between all parameters in a process, the user can choose which parameters he wants to use as input parameters. The rest of the system can be calculated.

In an E-Module the input parameters (blue cells) represent values that are easy to measure or are usually available in the process control system. It may occur that the user has other input parameters available than the ones specified in the modules.

If this occurs there are several possibilities. Firstly, you can completely change the calculations in order to define a different parameter as an input parameter, however, this is a long and difficult way. As an alternative an iterative solution can be quickly obtained using the “What-If-Analysis” or the “Solver” tools which are integrated in Excel.

If a defined input parameter (blue cell) is unknown and should be defined by another parameter (green cell), the following example shows a step-by-step proceeding that is to be followed. It is required that the “old” input parameter (blue cell) is directly or indirectly linked to the “new” input parameter (green cell).

The E-Module used in the example is the “Thermal Vapour Recompression”, shown in Figure A.9. This process mixes a high pressure steam (motive steam) with a low pressure steam (entrained vapor), in order to obtain a medium pressure steam (discharge mixture). The mixing is done in a nozzle which creates a vacuum to aspire the entrained vapor.

This kind of system can, for example, be used when exhaust vapor of a process is at a pressure level (temperature) which is too low to allow re-using it in another part of the process. By using thermal vapor recompression, the low pressure exhaust vapor can be revalorized by mixing it with high pressure steam, producing a medium pressure steam.

As can be seen in Figure A.9, the mixing of the three streams is defined using the six following input parameters:

- Motive steam: pressure and temperature
- Entrained vapour: pressure and temperature
- Discharge mixture: pressure and mass flow

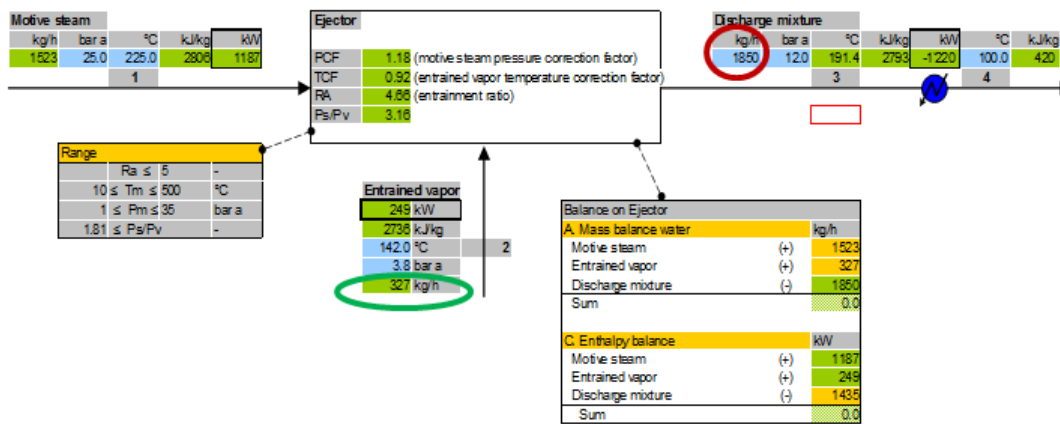

Fig. A.9: Thermal Vapor Recompression E-Module

The mass flows of the motive steam and the entrained vapour, as well as the temperature of the discharge mixture are all determined by the six input parameters (using an empirical formula).

Let’s now consider that the mass flow of the entrained vapour (the exhaust vapour which we want to re-use) is known in a process, as well as its pressure and temperature. We know as well the temperature and pressure of the motive steam (fresh steam in the utility system) and we estimate which pressure level a medium pressure steam (discharge mixture) must have to be usable in the process.

Now it would be useful to calculate how much medium pressure steam we can produce, using all the exhaust vapour which is available. But the input parameters we have do not fit with the input parameters defined in the PEM. In fact we want to define the mass flow of the entrained vapour instead of the mass flow of the discharge mixture.

This can be easily done without changing the calculations by using the “What-If-Analysis” (German: Was-wäre-wenn-Analyse | French: Analyse scenarios) which is integrated in Excel. The following steps explain how to use this tool in the example. We assume that the mass flow of the entrained vapour, which we want to use as input parameter, is 700 kg/h. The rest of the parameters will stay the same.

1. On the menu go to:
Data → Data Tools → What-If-Analysis → Goal Seek
2. Within the Goal Seek Box the three following parameters are to be defined:

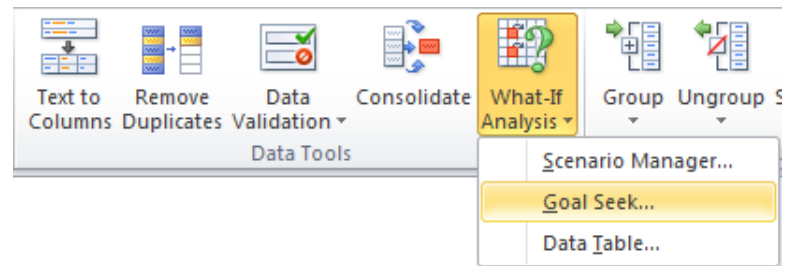

Fig. A.10: What-If-Analysis

- (a) “Set cell” (German: Zielzelle | French: Cellule à définir): The cell we want to use as input cell, but contains a formula. In the example the “set cell” is the mass flow of the entrained vapour, of which we have a measured value of 700 kg/h.
- (b) “To value” (German: Zielwert | French: Valeur à atteindre): The form “to value” is actually the value we want to attain in the “set cell”. In the example, we enter 700 (kg/h).
- (c) “Changing cell” (German: Veränderbare Zelle | French: Cellule à modifier): The cell which represents the input we don’t have. In the example it corresponds to the mass flow of the discharge mixture.

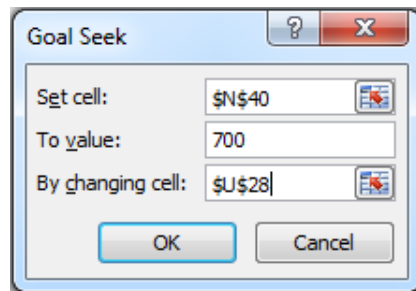

Fig. A.11: Goal Seek

3. By pressing the **Ok** button, Excel iterates the value in the “changing cell” until the value in the “set cell” reaches the target value in the “To value” cell.

As a result of the example we obtain a mass flow of the discharge mixture of 1850 kg/h. We found that at the given conditions we can produce this amount of medium pressure steam when 700 kg/h exhaust vapour are available.

Instead of using the “What-If-Analysis” it is also possible to use the solver (shown in Figure A.12). The solver must first be enabled under:

File → **Options** → **Add-Ins** → **Manage Excel Add-Ins**

Once enabled, it can be found under:

Data → **Analysis Tools** → **Solver**

The solver works basically the same way as the “What-If-Analysis”, but allows some additional possibilities such as finding minimum & maximum values or specifying a range of values for the input cell.

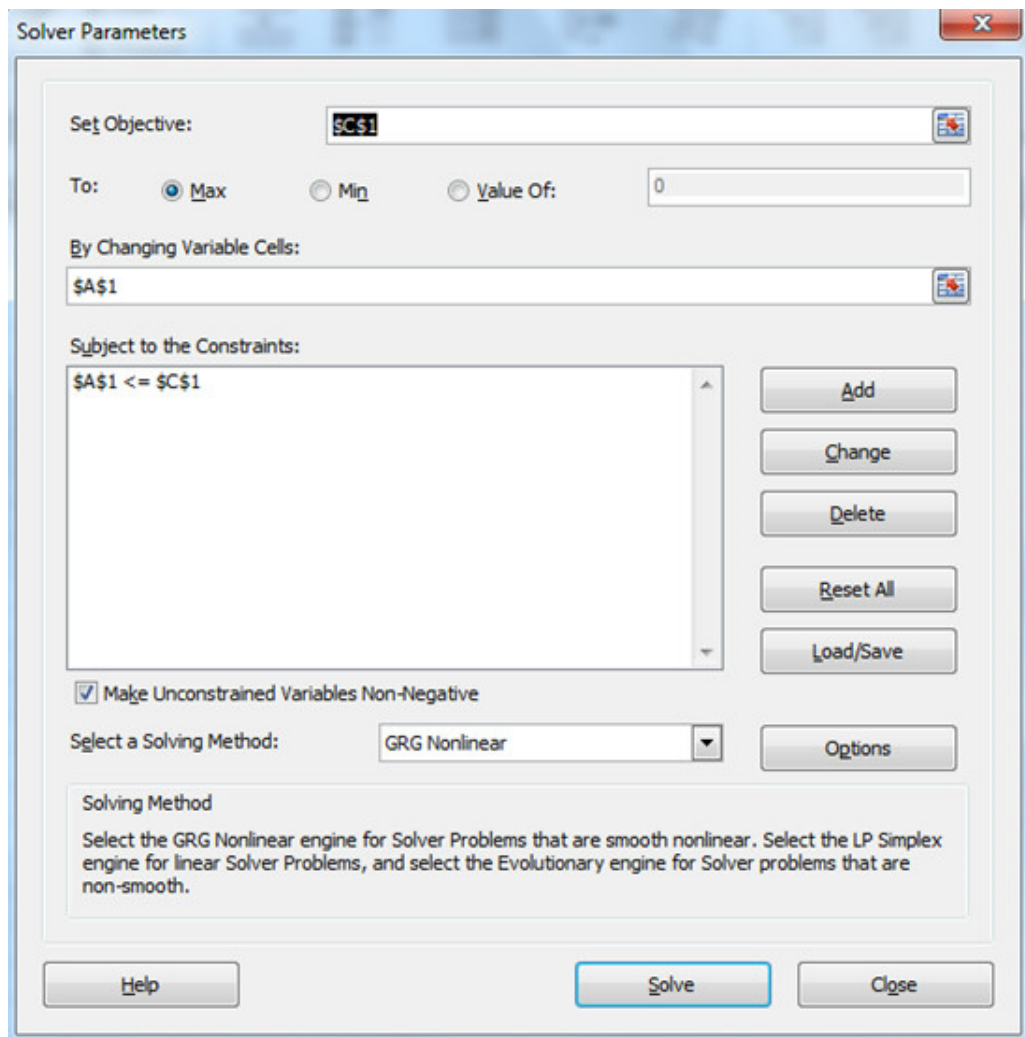

Fig. A.12: Excel "Solver" Tool

A.8 Developing Own E-Modules

It is possible for third party users to develop their own E-Modules (EM), which can be used in their PinCH projects. They can also make the EM they developed available to other PinCH users who in turn can use it in their own PinCH projects. For this reason it is important to maintain a high level of standardization throughout all EMs. Thus, this chapter contains guidelines for the development of new EMs as well as an explanation of the standards which have to be considered.

A.8.1 Preliminary to E-Module Development

When developing a new module, one should always keep in mind the aim of the energy related modelling, which is to obtain the definition of cold and hot streams in a process, with sufficient accuracy to perform the heat integration. Clearly, assumptions have to be made in order to facilitate the calculations and speed up the modelling, but the developer should be aware of the influence of the assumptions he makes and record them in the header of the module.

The aim is to obtain a solid and simple model out of a probably very detailed process. It is advisable to split up large processes into smaller sub-processes in order to guarantee their legibility.

When building a new module with the purpose to complete the database, it should be checked whether the module will also be useful for other users:

- Are there general process modifications possible before a Pinch Analysis is performed? Do these modifications make a Pinch Analysis obsolete? (E.g. minimize the evaporation rate by placing floating balls on the water surface or minimize the hood air flow in order to decrease the air velocity on the water surface etc.)
- Does the process have at least one hot/cold stream that can usually only be determined by energy and mass balances?
- Is there an existing EM that covers the process or that requires only a few changes to do so?
- In which other industries can the process be used?

- Is the process general enough to build a module? What is the multiplication potential?
- Does the description cover all different kinds of energetically identical processes or is a specific naming needed?
- Is the process or sub-process small enough, so that it allows future users to understand the calculations within a reasonable time? If not, split the process into sub-processes.
- Is there reasonable knowledge and documentation/data on the considered process available?

Once these points are confirmed, we can start to build a new module from scratch. In the following example we will have a look at the evaporation which occurs at the surface of a hot pool (represented in the EM “pool evaporation”).

This process represents for example a treatment bath for metal pieces. The fluid which evaporates at the surface of the pool is captured in a hood and expelled to the atmosphere. Because the pool is open to the room, ambient air is aspired as well.

The losses in the pool due to evaporation are constantly replaced by a re-filling mechanism. To assure the desired temperature in the pool, a heating system is installed. There are systems with either direct or indirect heating, which means there is either a heat exchanger placed in the pool (usually electric heating) or the fluid in the pool is pumped through an external heat exchanger.

In the example, the pool represents the process, which interlinks several cold and hot streams, as shown in Figure A.13. It is useful to draw a sketch of the process, in order to gain an overview of the parameters to define.

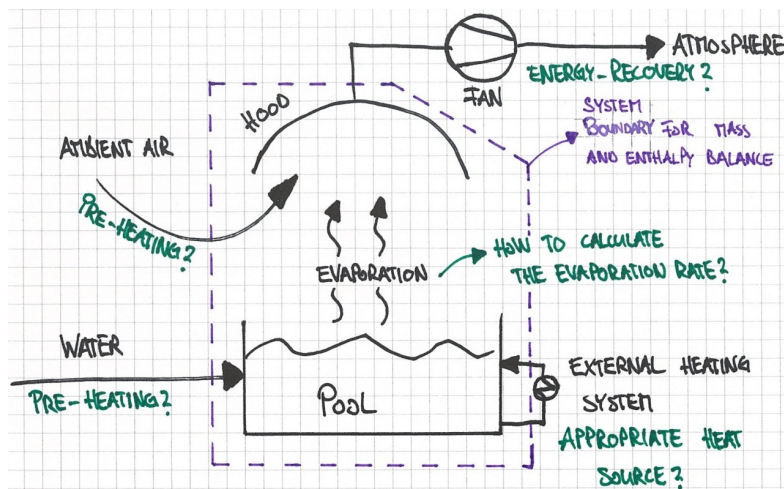

Fig. A.13: Example of a Useful Sketch of a Pool Process

Once the streams are chosen, we complete the sketch with some energy-related information and ideas:

- Definition of the system boundary for the mass and enthalpy balance of the process.
- Is it technically possible (and useful) to preheat the streams entering the process?
- Can energy recovery be done with streams leaving the process?
- Which is the best way to fulfil the heating and cooling requirements of the process?
- Are empirical formulas required?

Before starting to model the process in Excel, we spend some time to think about the input parameters we want to use by comparing it with different plants.

- Is the process always done this way, are there other alternatives?
- Which of the alternatives is the most representative? Or better? Is there a way the EM can be defined in order to cover various alternatives (e.g. with some optional streams)?
- Will the EM be useful for a different application in another industry? If so, general and yet understanding naming is essential.

- What are the parameters that are usually available? (e.g. use product-relevant parameters which are measured by the process control system and therefore quickly available)
- Are the parameters available in all processes the energetic model is used for or are other common values available? If so, describe in the module header how the “what-if-analysis” or the “solver” should be used in order to use the module in different directions.
- Which parameters are easy to obtain/measure (e.g. the bath temperature is easier to measure than the exhaust air flow)? If possible, use these easy parameters as input.
- Can the energy and mass balances be closed with the available parameters?
- What were the assumptions and simplifications made when calculating the modules the way we planned it?
- Do these assumptions hold in most cases?
- What are the most sensitive parameters?
- What are the uncertainties of these parameters?
- Can I determine the energy and mass balance with reasonable accuracy? (Remember, the EMs should not represent an engineering tool for plant layout, but help the engineer to quickly and roughly determine energy flows.)
- **Are there other ways to model the stream table which might prove beneficial from a process integration perspective?** Can, for example, two streams be combined into one stream in order to save heat exchanger costs?

After having checked the questions above, it should be possible to define which will be the input parameters and how the calculated values will be determined (e.g. using thermodynamic laws or empirical formulas). The next step will be to build the EM in Excel, respecting the standardization rules of the EMs.

A.8.2 Standardized Design

The standardization aims at:

- Simplifying and speeding-up the development and the maintenance of documentation and of software code.
- Ensuring a uniform philosophy and look of the modules to ease the understanding, the application and possibly the modification by the end user.
- Maximizing the applicability range of modules for a given set of basic modules.
- Allowing end-users to develop modules by means of a simple yet comprehensive supporting documentation and the use of a standard software environment.

Let us now start to build the module in Excel. Create a new Excel sheet and draw the process (here the pool). The process is usually represented as a box with black frame. In the example, we replaced the top frame by a wavy line in order to visualize the water surface (see Figure A.14).

The next step is to represent the streams. In the example, the required streams are the pool refill, the air leaving the system and the external heating system. The aspired ambient air is not really a stream here, because it is not ducted.

To build the streams, copy them from the standard blocks into the new EM. As shown in Figure A.14, we copy a water stream for the pool refill, a wet air stream for the waste air and again a water stream for the heating system. For the specification of the ambient air, we put an empty box. After copying the streams, we copy from the standard blocks the predefined mass and enthalpy balance.

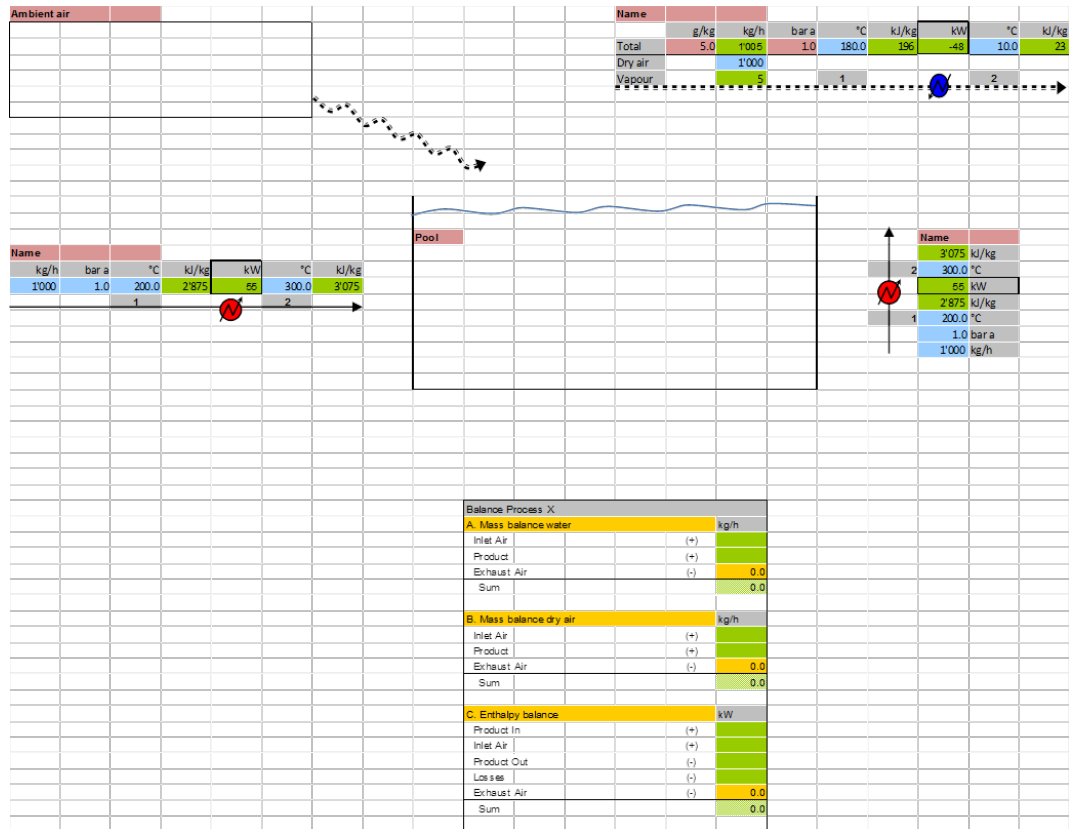

Fig. A.14: Sketch of Pool Process

Now, we can start to define the calculations and interlink the streams. Because a preliminary analysis has been done as described in section A.8.1, we know which values are available and which parameters can be calculated.

We can start to calculate values out of the available input parameters and interlink the streams between each other. When interlinking the streams it is important to do this indirectly using the mass and enthalpy balance, this avoids long calculations in single cells. To be able to calculate all input and output streams, we also need to estimate the evaporation rate at the pool surface. To do so, we use an empirical formula, of which we place the necessary parameters directly in the box representing the pool. To make the formula available to the user of the EM we will later on make a quotation in the header of the module.

The finished model of the process is shown in Figure A.15. Where required, it is possible to add extra information to the model, using the predefined information box in the standard blocks. When the elements defined in the standard blocks are not sufficient, it is possible to use self-designed blocks or

boxes, however, ensure to adhere to the standard colour code.

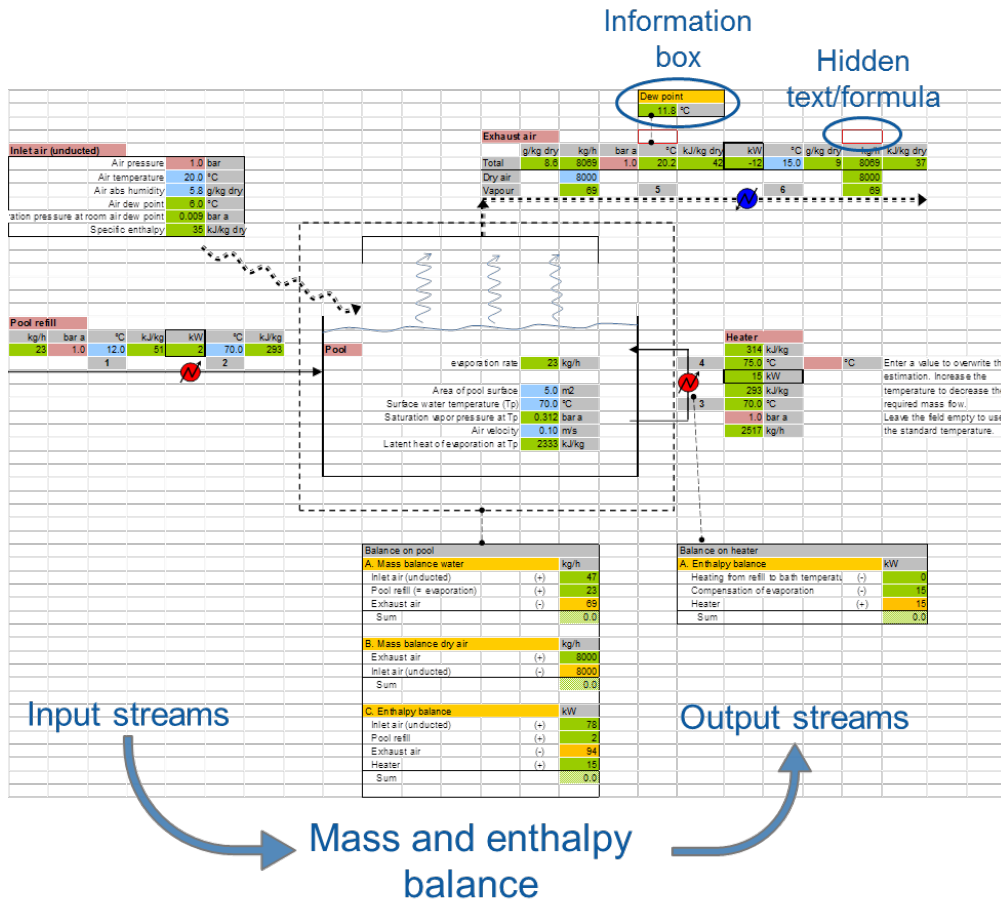

Fig. A.15: Finished Model

In the example, we added an extra enthalpy balance for the heater. For the exhaust air stream we added an information box indicating the dew point temperature for the given humidity and temperature of the air. The red frame indicates that the cell contains information which is not permanently visible. In the example, a warning appears when the temperature of the air is below the dew point temperature and condensation occurs (visible in Figure A.16). When the air temperature is above the dew point temperature, the warning disappears and the red frame indicates that the cell should not be deleted or overwritten.

Last but not least, we add the following elements, as shown in Figure A.16:

- The header, which describes the module and helps the user to under-

stand the process and the calculations. Further information of what must be mentioned in the header can be found in section A.8.4.

- The legend should not be missing, thus the user can quickly understand the meaning of the colouring. This can be copied from the standard blocks.
- The stream table summarizes hot and cold streams and prepares the data to be copied into PinCH (see section A.8.8. It should also help the user to understand how a stream is correctly modeled for heat integration. In the example, the heater is represented as an external heat exchanger, which elevates the temperature of the fluid in the pool to a given target temperature. The cold stream to be heated up is therefore the fluid in the pool. The appropriate heat source to do so is defined later in the process of heat integration. The exhaust air is finally defined as a hot soft stream, as it can be used for energy recovery, however, it does not have to be cooled down from a process perspective.

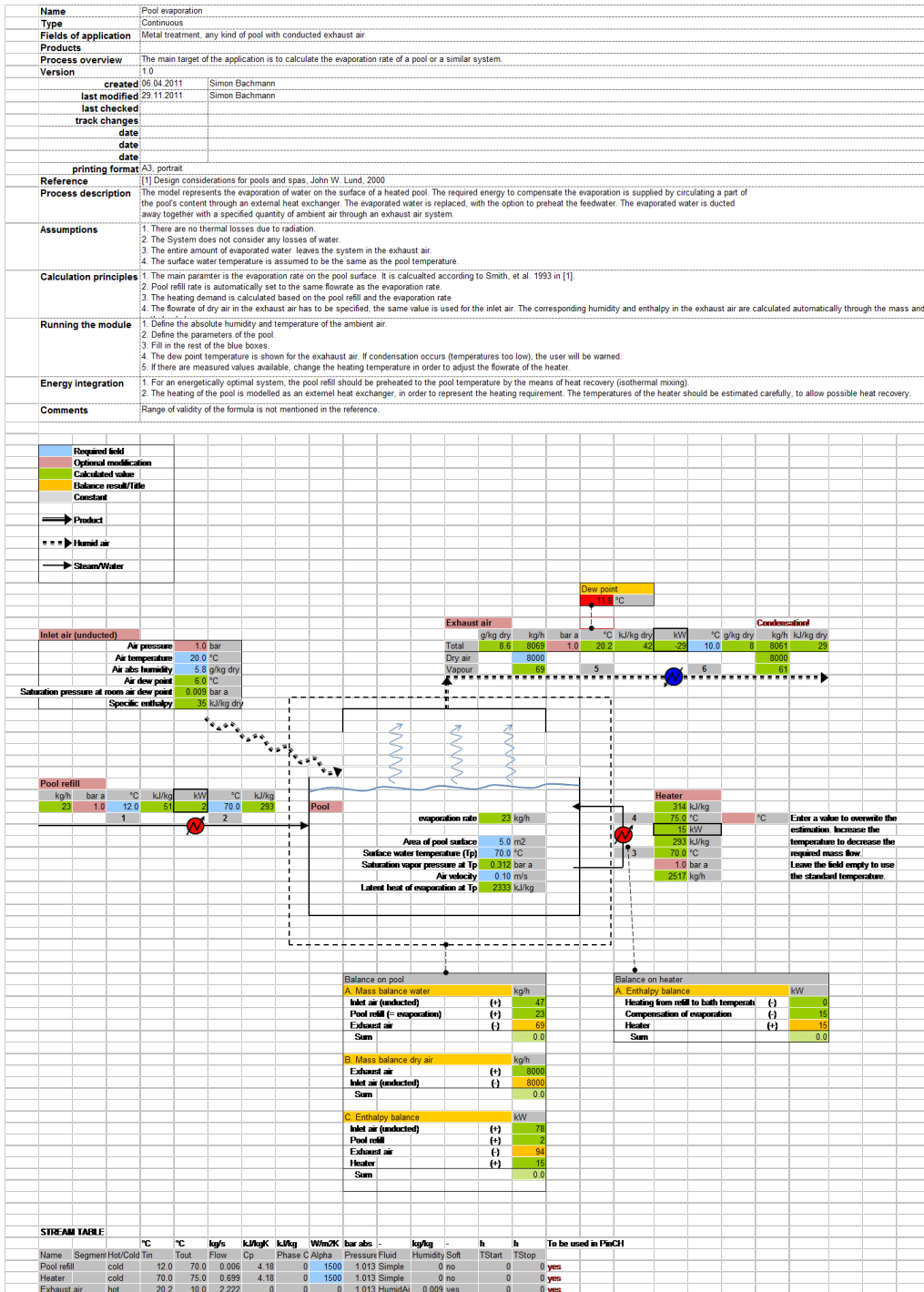

Fig. A.16: Finished PEM

A.8.3 Development Procedure

The most important points concerning the development of a EM in Excel are summarized next:

Main steps for building E-Module in Excel

- Respect steps preliminary to module development
- Module GUI layout and structure (respect standardization rules)
- Module specific documentation (respect standardization rules)
- Quality check

Standardization rules for building an E-Module

- Manageable size – this allows for quick understanding
- Use standard blocks wherever possible
- Respect the coloring defined for the standard blocks
- Necessary elements of an EM:
- Use the predefined quality checklist to ensure that the modules respect the standards

Figure A.17 shows the standard procedure to follow when developing a new EM. There are some important steps to be considered before and after the actual development and calculations in Excel in order to assure the quality of the module.

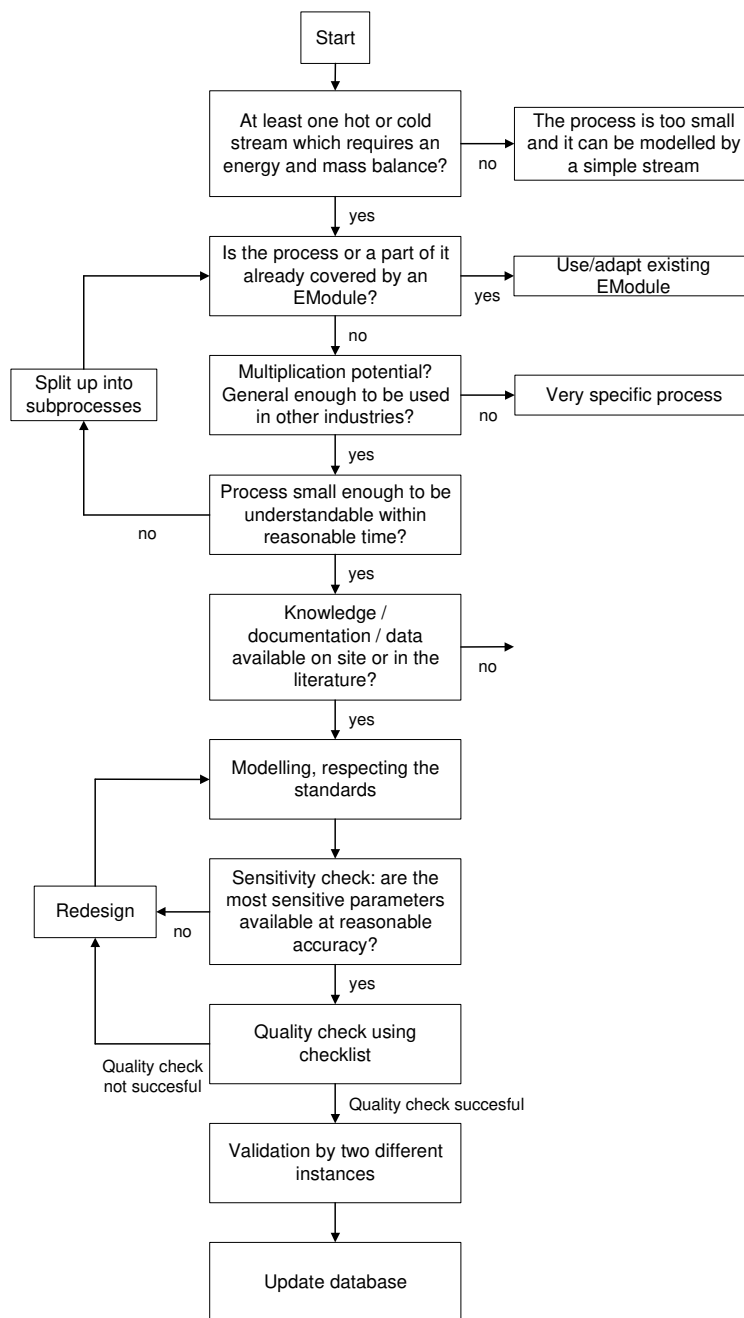

Fig. A.17: Standard Procedure

A.8.4 Standard Elements

Standard Blocks

The standard blocks contain the required elements to build an EM. The most important elements are the predefined hot and cold streams (represented by a heat exchanger).

Every stream is defined in all possible directions and with different dimensions in order to facilitate the construction of new modules. There are four different kinds of standard streams defined. These are:

- Product (a mixture of any product with a certain amount of water)
- Single product (a product without water content)
- Humid Air (air with a certain water content)
- Water and steam (the solid/liquid/vapour state is automatically calculated).

In the standard blocks it is assumed that the mixture of the products is ideal if not otherwise mentioned and pressure drops through the heat exchanger are neglected.

In addition, the standard blocks also contain predefined designs for the following elements:

- An empty header
- The legend, explaining the colouring and types of streams
- Information box (to represent additional information for a stream)
- Text box to indicate critical values and hidden formulas
- Enthalpy and mass balance for continuous process
- Time dependent representation of batch streams
- Predefined stream table

The standard blocks should be used wherever possible in order to keep the design of the EMs uniform (see **Standard blocks and symbols.xlsx** and **blank module.xlsx**). This will help the user to get started with a module.

If a required element is not available in the standard blocks, the developer can create a new block in the style of the existing design and standard colours.

Header

The header represents an important element of the EM. It should be designed with care as it is the key to making the module understandable for future users. The header consists of the elements shown in Table A.6:

Tab. A.6: E-Module Header

Name	Short and clear name, used to identify the module in the database. Avoid long phrases or descriptions	
Type	Type of the module: continuous or batch.	
Fields of application	Possible industries in which the module could be useful. The idea is to expand this library continuously	
Products	Products that result in the process which the module covers	
Process overview	Short description of the process. The process overview is the description that is used in database.	
Version	Version number of the module. The same number should be mentioned in the file name.	
Printing format	Paper size and orientation	
Reference	All external formulas must be quoted here with a source, so that the calculations are transparent to the user.	
Process description	Detailed description of what happens in the equipment and how. If batch operated, describe the different process stages	
Assumptions	Major assumption made due to simplifying the process for the E-Module are given here.	
Calculation principles	Gives idea of how the different elements in a module are calculated (important calculation principles explained here).	
Running the module	Guides the user through the module and explains the order the input values should be entered, how to use implemented macros and which values must be modified when using the solver.	
Energy integration	Hints and common techniques for energy integration in the specific process.	
Comments	Any additional comments from the developer.	

Legend

The legend should be present in every EM. It describes the coloring and the different types of streams. It can be copied from the standard blocks.

Description of Stages (Batch Only)

For batch processes, the names of the different stages in the process are defined in a separate box. To do so, a predefined box is available in the standard blocks (Description of stages). It allows the user to enter a name for every stage in the batch process. The names should be copied automatically to the corresponding streams further down in the batch process.

The reason to place this box is to have the names of all stages close to the graphical representation of the batch process (see for example the E.Module Reaction tank).

A.8.5 Standard Appearance

Colors





Use the colors which are defined in the standard blocks and shown in Table A.7 & A.8. Once you have copied the legend or a standard block into the new module, the easiest way is to use the format painter to transfer colors from one cell to the another:

Home → Clipboard → Format Painter





To increase the legibility, the background is completely white (no cells visible). Use:

Home → Font → Borders – set all the borders to white

Tab. A.7: Cell Colors and Types

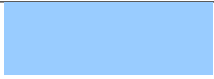
	Required field
	Optional modification
	Calculated value
	Balance result & Titles
	Constants



Tab. A.8: Cell Colors RGB Codes

Standard Colors for EMs:					
					
R	153	218	153	255	217
G	201	150	204	192	217
B	255	148	0	0	217

Types of Streams

Use the predefined lines for different types of streams as defined in the standard blocks and shown in Table A.9. A product stream represents either a wet or dry product. It stands for the main good to be treated in a process.

Tab. A.9: Types of Streams

	Product
	Humid air
	Steam/Water

Design of the Process

The assembly of a continuous process and its streams should be similar to the representation in a flow sheet, so that the user quickly understands what the module represents. The predefined streams in the standard blocks should be used. The process itself is represented by a black frame, containing at least one cell for specifying the name of the process. If required, add additional information directly inside the black frame or by using an information box as shown in Figure A.18.

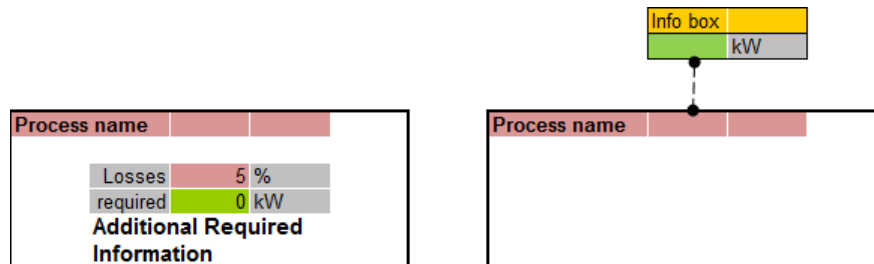

Fig. A.18: Representing a Process

Symbols

Some symbols are defined in the standard blocks such as heat exchangers, evaporation and losses. Where required define new symbols, try to choose them as self-explaining as possible.

Font

The font used in EMs is Arial with a font size of 10. Text that is highlighted uses the same font and size and should be in bold (e.g. for names, titles, etc.).

Cell Size

All cells, except for the descriptions in the header should have a width of 53 pixels (or a value of 6.86) and a height of 18 pixels (13.5). Where necessary, the cell format can be larger (e.g. to display large numbers or long names).

Number Format

The standard number format is defined in the streams of the standard blocks. If a different number format is required then the designer is free to change it. Remember that the EMs are not exact simulations, therefore, too many decimal places will give the user a wrong feeling of precision.

Merged Cells

There should not be any merged cells except for in the header. This is because copying or moving merged cells is not always possible.

Information Boxes

The information box can be added from the standard blocks either to define additional information, which is often required, or to represent an intermediate calculation step (i.e. if putting the entire calculation in a single cell would be too complicated).

A.8.6 Standard Naming

Numbering of States and Stages

Ensure that states and stages are numbered correctly and in a comprehensible order. For standard blocks a state is always defined by a number in a grey cell. As the temperature is the main characterisation of a state in Pinch Analysis, the state-numbering is always next to the temperature field.

°C	kJ/kg	kW	°C	kJ/kg
20.0	33	4038	198.0	215
5			6	



Fig. A.19: Numbering Stages

Naming Cells

In most cases, the units defined in the standard blocks should be sufficient to describe the value in the cell. Where necessary, add an additional cell which describes the unit. For an overview of the used units and their abbreviations, see table A.2.

Standard m3	5466	Nm3/h
Operating m3	7067	m3/h

Fig. A.20: Naming Cells

Standard Names of Streams

General – The names of streams should describe the stream in such a manner that the user understands the stream's purpose. Unique names for the streams should be used as they will be used in PinCH to distinguish the streams.

Standard names are defined in Table A.10 below and should be used wherever possible. However, if required, other names than the standard names can be defined.

Tab. A.10: Name and Description of Standard Streams

Stream Name	Description
Product Inlet	Stream which represents the product entering a continuous process.
Product Outlet	Stream which represents the product leaving a continuous process.
Inlet Air Exhaust Air	Air entering the process from the environment. Air leaving the process, usually loaded with water vapour or particles.
Exhaust Gas	Combustion product leaving the process.
Exhaust Vapours	Vapour produced in the process, possibly polluted.
Combustion Products	Gas after combustion, intermediate state before leaving the system.
Fuel	Fuel entering the process.
Product Feed	Stream which represents the product entering a batch process.
Product Discharge	Stream which represents the product leaving a batch process.

A.8.7 Standard Calculations

Mass and Enthalpy Balance

Balances within processes should always be done in the corresponding mass and enthalpy balance box, which is defined in the standard blocks. It should be avoided passing values directly from one stream to another because this leads to long formulas which are difficult to unscramble. Figure A.21 shows how the information flow should be (blue) and how it should not be (red). Exception: merging/mixing of streams.

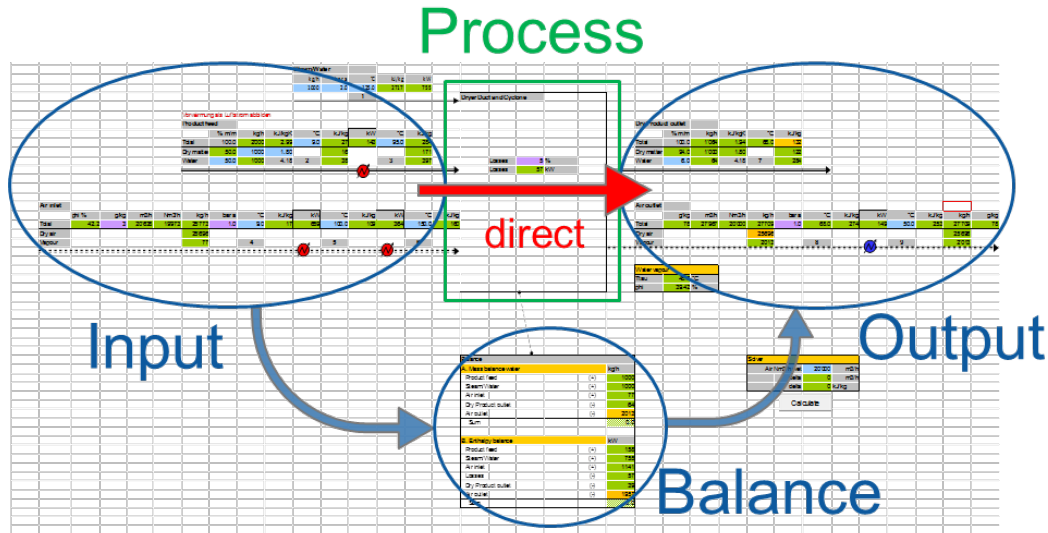

Fig. A.21: EM Data Flow

Formulas

Be aware that formulas in Excel can become difficult to understand. Assure that the formulas are comprehensible for the end user. Avoid long formulas and define, if necessary, intermediate steps in an information box.

Assumptions

Any major assumption must be recorded in the header. This helps the user to understand the calculations and to evaluate if the assumptions are reasonable for his process.

Warnings

The modules are not meant to be fool-proof. Nevertheless, the most common entry mistakes should be covered by a warning. To do so, a warning cell is defined for each critical value and marked by a red frame. At the same time as the warning occurs, the cell turns red (use conditional formatting, Home → Styles → Conditional Formatting).

Example (Figure A.22 & A.23): Condensation occurs because the outlet temperature after the heat exchanger is below the dew point (10°C while the dew point is at 11.8°C). The warning Condensation! occurs and the cells containing the dew point and the vapor mass flow turn red.

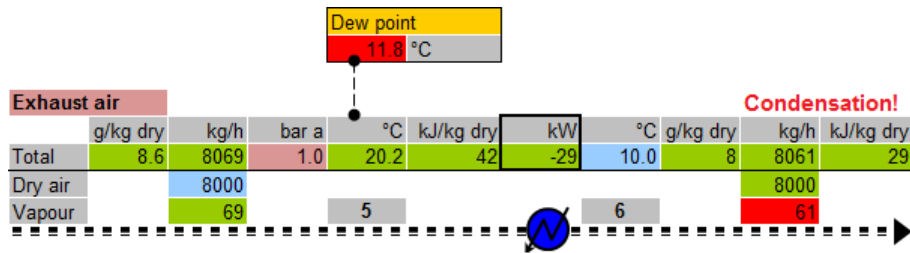

Fig. A.22: Representation of a Warning

When increasing the temperature to 30°C, the warning disappears and the cells return back to their original colour. In order to mark the cell with the formula containing the warning, a red frame appears. The red frame and an example of a warning are defined in the standard blocks.

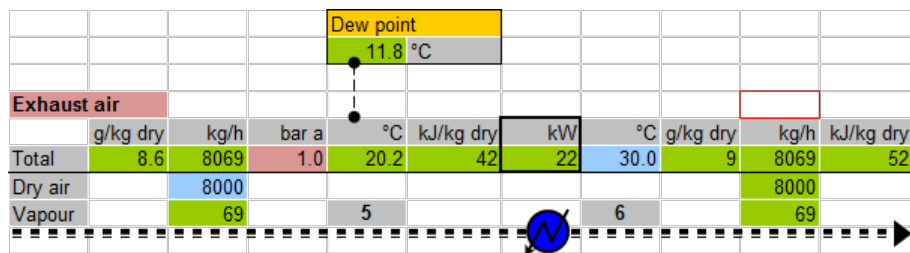

Fig. A.23: Representation of a Hidden Formula

Absolute references

Always use relative references and avoid absolute references (i.e. avoid \$A\$5) in order to make copy-paste into other sheets possible at any time. Use “find and replace (ctrl + h)” to easily remove all \$ signs if any were added during development.

Overwrite estimations

Overwriting of suggested values by an entry of the user: the suggested value should disappear when overwritten, so that it is clear which value is used in calculations as shown in Figure A.24.

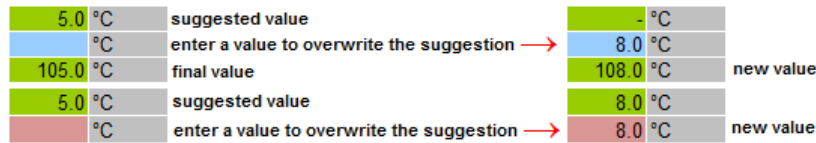

Fig. A.24: Overwriting Estimations

Circular references

In some processes, it is not possible to avoid circular references in the calculations. Either there is a recirculated fluid (closed loop) or there is not enough (measurable) input data available. The workaround is to use the solver. To facilitate the handling of modules, it should be possible to run the solver via a script, which is activated by a button as shown in Figure A.25. The Delta represents the balance difference of a circular reference. The macro closes the balance by adapting a specific parameter (e.g. the inlet air flow).

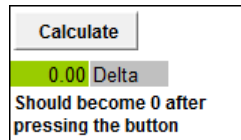

Fig. A.25: Script Button

A.8.8 Standard Stream Table

The stream table gathers the information which is required for the Pinch-Analysis. A predefined stream table can be found in the standard blocks. It has the format as shown in Figure A.26.

STREAM TABLE															
Name	Segment	Hot/Cold	Tin	Tout	kg/s Flow	kJ/kgK Cp	kJ/kg Phase C	W/m2K Alpha	bar abs Pressure	- Fluid	kg/kg Humidity	- Soft	h TStart	h TStop	To be used in PinCH
			°C	°C											yes
															no
															yes

Fig. A.26: Stream Table

The stream table is composed as shown below. The data should be automatically copied from the corresponding stream (except for the blue cells). It is not necessary that all the cells in the stream table contain values. For more information about necessary parameters in the stream table, see chapter 4.

- **Name:** the name of the stream is automatically copied from the process model.
- **Segment:** Numbering of a segment, only necessary if the segmentation of a simple stream is required (see e.g. module Evaporator). It is left empty in case of non-segmented streams or in the case of predefined fluids (e.g. Water, Humid Air) as PinCH segments these streams automatically.
- **Hot/Cold:** defines if the stream is hot or cold. Adapt the definition to the corresponding stream. For streams which can be hot or cold, define a formula.
- **Tin:** stream inlet temperature.
- **Tout:** stream outlet temperature.
- **Flow:** mass flow of the stream in kg/s.
- **Cp:** specific heat of the fluid. The Cp is required if the fluid is specified as simple (see below under Fluid).
- **Phase Change:** specific heat of the fluid when changing phase. Only required for simple fluids which change phase. For fluids which are predefined in PinCH, the phase change is calculated automatically based on temperature and pressure.
- **Alpha:** heat transfer coefficient, depending on the fluid.
- **Pressure:** required when other values have to be calculated automatically, i.e. for steam or wet air. Not required for simple fluids.
- **Fluid:** Simple fluid means that the fluid is defined by Cp, temperatures and mass flow. Other fluids such as Water or Humid Air will be automatically completed in PinCH using an internal properties library. See PinCH for further explanation regarding the available fluids.
- **Humidity Ratio:** absolute humidity for humid air, in kg water per kg dry air. Required when for humid air only.
- **Soft:** indicates if a stream is a soft stream or not. A soft stream is a stream which does not require cooling or heating from a process point of view, but can be cooled/heated for the purpose of energy recovery. A soft stream is, for example, hot air which leaves the process to the atmosphere.

- **TStart:** time at which a stream starts, used for batch processes. Scheduling of continuous processes can be done after import into PinCH.
- **TStop:** ending time of a stream.
- To be used in PinCH: indicates whether a stream must be copied into PinCH or not. Sometimes, several streams in a module are unused (flow rate is zero) and therefore does not have to be copied into PinCH. The definition of this cell must be adapted to the corresponding stream. (**Note:** This column should not appear in the E-Module stream table, it is only a reference for the Excel stream table.)

A.8.9 Protection

Cell Protection

To be defined as needed.

Unlock Key

To be defined as needed.

A.8.10 Files and Printing

Filename

The filename must be the same as the name of the module which is specified in the header. The filename is followed by the version number (e.g. name-ofthemodule 1.2.xlsx).

Printing

The printing area should be defined so that the entire worksheet is printed. Paper size should be large enough so that the print is readable.

Header and footer

The header is empty while the footer contains the path, filename, date and page number.

A.8.11 Quality Management

In order to assure the quality of finalized EMs a detailed quality checklist has been established. It serves to check a finished EM step by step. Once the module is finished, the developer should ensure whether the new EM respects all the points mentioned in the quality checklist and accomplish the tests defined. Nevertheless, the quality checklist can be useful during design and development of a EM, to assure that the standards are followed.

Quality Checklist

Module Header		
Name	Clear and short?	<input type="checkbox"/>
Type	Defined (continuous or batch)?	<input type="checkbox"/>
Fields of Application	Are all possible fields of application mentioned?	<input type="checkbox"/>
Products	Are the most important products of the module's process(es) listed?	<input type="checkbox"/>
Process Overview	Is the overview short enough, so that the user can read through several process overviews when searching a module? Is the overview accurate enough, so that the user finds the correct module covering his process?	<input type="checkbox"/>
Version and Changes	Is the tracking up to date?	<input type="checkbox"/>
Printing Format	Is the printing format defined correctly? Are header and footer defined? Check paper size, orientation and printing area.	<input type="checkbox"/>
Reference	Do all essential formulas used in the calculations have a reference?	<input type="checkbox"/>
Process Description	Is the description clear enough to provide a comprehensive picture of what happens in the process and which data is required for the calculation?	<input type="checkbox"/>
Assumptions	Are all assumptions and simplifications explained?	<input type="checkbox"/>
Calculation Principles	Are the closing of energy and mass balances explained (correctly)?	<input type="checkbox"/>
Running the Module	Is the order of entering data explained? What are the sensitive parameters and how do they influence the result? Are the most common alternatives to run the module explained (e.g. calculating the inlet air mass flow using the solver if the exhaust air temperature is known)?	<input type="checkbox"/>
Energy Integration	Are the alternative stream models used in the stream table explained (e.g. Combine all inlet air streams into one stream and define the maximum common temperature as the target temperature. Define the remaining stream parts as streams.)? Are the most common ways to decrease the energy consumption independently of the EM explained?	<input type="checkbox"/>
Comments		<input type="checkbox"/>

Legend												
Legends, signs & symbols	<p>Are all the types of lines explained? (e.g. product stream, water etc.)</p> <div style="border: 1px solid black; padding: 5px; margin: 10px 0;"> <p> Required Field</p> <p> Optional Modification</p> <p> Calculated Value</p> <p> Balance result / Titles</p> <p> Constant</p> <p>→ Product</p> <p>▣▣▣ Humid Air</p> <p>→ Steam / Water</p> </div>	<input type="checkbox"/>										
Description of stages (batch only)	<p>Is the standard box for describing stages available? Are the entered names automatically transferred to each stage?</p> <div style="border: 1px solid black; padding: 5px; margin: 10px 0;"> <p>Description of stages</p> <table border="1" style="width: 100%; border-collapse: collapse;"> <tr> <td style="background-color: #FFD700;">STAGE 1</td> <td style="background-color: #F08080;">Name of stage 1</td> </tr> <tr> <td style="background-color: #FFD700;">STAGE 2</td> <td style="background-color: #F08080;">Name of stage 2</td> </tr> <tr> <td style="background-color: #FFD700;">STAGE X</td> <td style="background-color: #F08080;">THE NAMES ARE COPIED DOWN</td> </tr> <tr> <td style="background-color: #FFD700;">STAGE X</td> <td style="background-color: #F08080;">TO EACH STAGE OF THE PROCESS</td> </tr> <tr> <td style="background-color: #A9A9A9;">1.X</td> <td style="background-color: #A9A9A9;">Step X of stage 1</td> </tr> </table> </div>	STAGE 1	Name of stage 1	STAGE 2	Name of stage 2	STAGE X	THE NAMES ARE COPIED DOWN	STAGE X	TO EACH STAGE OF THE PROCESS	1.X	Step X of stage 1	<input type="checkbox"/>
STAGE 1	Name of stage 1											
STAGE 2	Name of stage 2											
STAGE X	THE NAMES ARE COPIED DOWN											
STAGE X	TO EACH STAGE OF THE PROCESS											
1.X	Step X of stage 1											

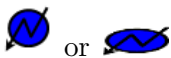
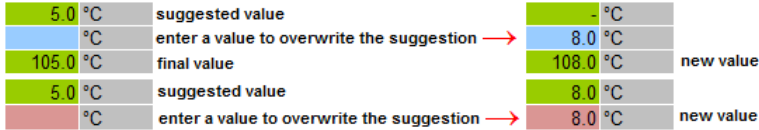
Appearance		
Font	The standard font is Arial with size 10. Select all cells (ctrl+a) and set the correct font and size.	<input type="checkbox"/>
Cells	Do all cells within the process have a width of 53 pixels (or a value of 6.86) and a height of 18 pixels (13.5)? Where necessary, the cell format can be larger (e.g. to display big numbers)	<input type="checkbox"/>
Header and footer of page	The page header is to let empty, the footer contains path and filename, current date and page numbering.	<input type="checkbox"/>
Process	Does a look on the entire process give the user an idea of what the process does and which streams have to be defined?	<input type="checkbox"/>
Colouring	Are the correct colours used for each cell? Especially blue cells must not contain any formulas, because they will be overwritten by the user.	<input type="checkbox"/>
Types of streams	Are streams represented correctly? (product/air/water/steam)	<input type="checkbox"/>
Symbols	Do the symbols have the correct ratio? 	<input type="checkbox"/>
Number Format	Does the number format make sense (i.e. 4.3 kg/h instead of 4.29534555 kg/h)? The standard number format is defined in the standard blocks. Remember that the EMs are not exact simulations, thus, too many decimal places will give the user a wrong feeling of precision.	<input type="checkbox"/>
Merged cells	There should not be any merged cells except for the header. This is because copying merged cells causes troubles.	<input type="checkbox"/>
Absolute references	Use relative references always and avoid absolute references (i.e. \$A\$5) in order to make copy-paste possible any time. Use “find and replace (ctrl + h)” to easily remove all \$ signs.	<input type="checkbox"/>
Overwrite estimations – depending on process	Overwriting of values: The suggested value should disappear when overwritten so that it is clear which value is used in the calculations. 	<input type="checkbox"/>

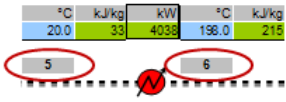
Naming										
Numbering of states and stages	Are the states and stages numbered correctly and in a comprehensible order?	<input type="checkbox"/>								
										
Naming cells	Are cells named correctly (units are defined in the standard blocks)? Are the units clearly defined (i.e. Nm ³ /h instead of m ³ /h, bara instead of bar)? If the unit does not provide enough information then add a short text/name.	<input type="checkbox"/>								
	<table border="1" data-bbox="542 795 901 851"> <tr> <td>Standard m³</td> <td>5466</td> <td>Nm³/h</td> <td>kg/h</td> </tr> <tr> <td>Operating m³</td> <td>7067</td> <td>m³/h</td> <td>2'530</td> </tr> </table>	Standard m ³	5466	Nm ³ /h	kg/h	Operating m ³	7067	m ³ /h	2'530	
Standard m ³	5466	Nm ³ /h	kg/h							
Operating m ³	7067	m ³ /h	2'530							
Naming of blocks / streams	Is the name meaningful? Does it correspond to the standard?	<input type="checkbox"/>								
	<table border="1" data-bbox="542 974 694 1008"> <tr> <td>Product inlet</td> </tr> </table>	Product inlet								
Product inlet										

Standard Names of Streams		
General	The names of streams should describe the stream, so that the user understands the purpose of the stream. Unique names for the streams should be used they will be needed in PinCH to distinguish the streams. Standard names are defined below and should be used wherever possible. However, if more adequate, other names than the standard names can be defined.	<input type="checkbox"/>
Product inlet	Stream which represents the product entering a continuous process.	<input type="checkbox"/>
Product outlet	Stream which represents the product leaving a continuous process.	<input type="checkbox"/>
Inlet air	Air entering the process from the environment.	<input type="checkbox"/>
Exhaust air	Air leaving the process, usually loaded with water vapor or particles.	<input type="checkbox"/>
Exhaust gas	Combustion product leaving the process	<input type="checkbox"/>
Exhaust vapors	Vapor produced in the process, possibly polluted	<input type="checkbox"/>
Combustion products	Gas after combustion, intermediate state before leaving the system.	<input type="checkbox"/>
Fuel	Fuel entering the process	<input type="checkbox"/>
Product feed	Stream which represents the product entering a batch process.	<input type="checkbox"/>
Product discharge	Stream which represents the product leaving a batch process.	<input type="checkbox"/>

Calculations		
<p>Mass and enthalpy balances</p>	<p>Are the mass and enthalpy balances used as they should be? Balances within processes should always be done in the corresponding box and values should not be given directly from one stream to another. Exception: merging or mixing of streams.</p>	<input type="checkbox"/>
<p>Units</p>	<p>Are the calculations made using the correct units?</p>	<input type="checkbox"/>
<p>Formulas</p>	<p>Are the formulas comprehensible? Are all variable parameters within a formula accessible by an entry cell? No hidden values! If formulas are too long, an intermediate step (additional cell) can help to understand the calculation more easily.</p>	<input type="checkbox"/>
<p>Assumptions</p>	<p>If any assumptions or simplifications are made, are they mentioned in the header?</p>	<input type="checkbox"/>
<p>Warnings</p>	<p>Is the user being warned when a calculation is out of range? E.g. user forgets to run the script after having modified values and the humidity is more than 100%. Pay-attention: The modules are not meant to be fool-proof. Nevertheless, are the most common entry mistakes covered with a warning?</p>	<input type="checkbox"/>

Stream Table		
Values	Are the correct values copied into the stream table?	<input type="checkbox"/>
Hot/Cold	Correct definition? Does the definition change automatically if the stream can be either hot or cold?	<input type="checkbox"/>
Empty fields	Do all the fields which are not used to defined the stream contain a zero?	<input type="checkbox"/>
Fluid	When a fluid other than simple is defined, are all the necessary parameters copied into the stream table?	<input type="checkbox"/>
Soft streams	Correct definition?	<input type="checkbox"/>
To be used in PinCH	Is the definition correct?	<input type="checkbox"/>
Import test	Ensure that the stream table can be imported into PinCH, by copying it into a .csv file and importing the .csv file into PinCH.	<input type="checkbox"/>
Stream definition in PinCH	Compare the values in the imported stream table with the values in the original stream table. Is the definition still complete? (i.e. mass flow)	<input type="checkbox"/>

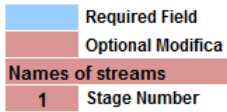
Protection		
Cell	Are the cells that must be modified by the user unprotected? 	<input type="checkbox"/>
Unlock key	Is the correct unlock key available and documented?	<input type="checkbox"/>

File		
Filename	Does the filename correspond to the name of the module defined in the header? Does the filename contain the same version number as defined in the header?	<input type="checkbox"/>
Folder	Is the module available in the corresponding folder?	<input type="checkbox"/>

Data Base		
Complete?	Has the module been added to the database?	<input type="checkbox"/>
Updated?	Are the version number and the description in the database up to date?	<input type="checkbox"/>

A.9 Multiple Operating Cases and Batch Supertargeting

Multiple operating case (MOC) and batch supertargeting is done to optimize the direct heat transfer possibilities between different operating cases (OCs) or batch time slices (TSs). Thanks to the direct analogy between OCs and batch TSs, the presented method of supertargeting can be used for the optimization of direct heat transfer possibilities of either batch processes or continuous/semi-continuous processes that form MOCs. Therefore, the term OC and TS can be used interchangeably.

In contrast to the "classical" pinch analysis of a single continuous process MOC and batch supertargeting requires an extension to the method to account for the reuse of common heat exchanger area between different OCs.

The reuse of the HEX area between different OCs/TSs generates coupling between the different OCs/TSs so their individual energy/cost tradeoff have an influence on the overall area. The goal of MOC supertargeting is to determine the "set" of ΔT_{min} values (1 per OC/TS), which results in the lowest total cost (The coupling between the OCs/TSs which arises through the reuse from HEX area makes the calculation of the "sets" of ΔT_{min} values for n-OCs (n-TSs) an n-dimensional problem.)

The theoretical foundation for the practical application of the MOC supertargeting was developed by P.S. Jones [16] and further elaborated in [17].

Design Types The reuse of HEX area is a complex optimization task so long as no clear limits on the possible "rearrangement" of HEX between the different OCs/TSs are made. Jones defined two main restricted design types - *Conventional Design* and *Resequenece Design*. In Figure A.27 is shown optimal HEN designs for two simple OCs to help illustrate the concept of reusing HEXs in these ways.

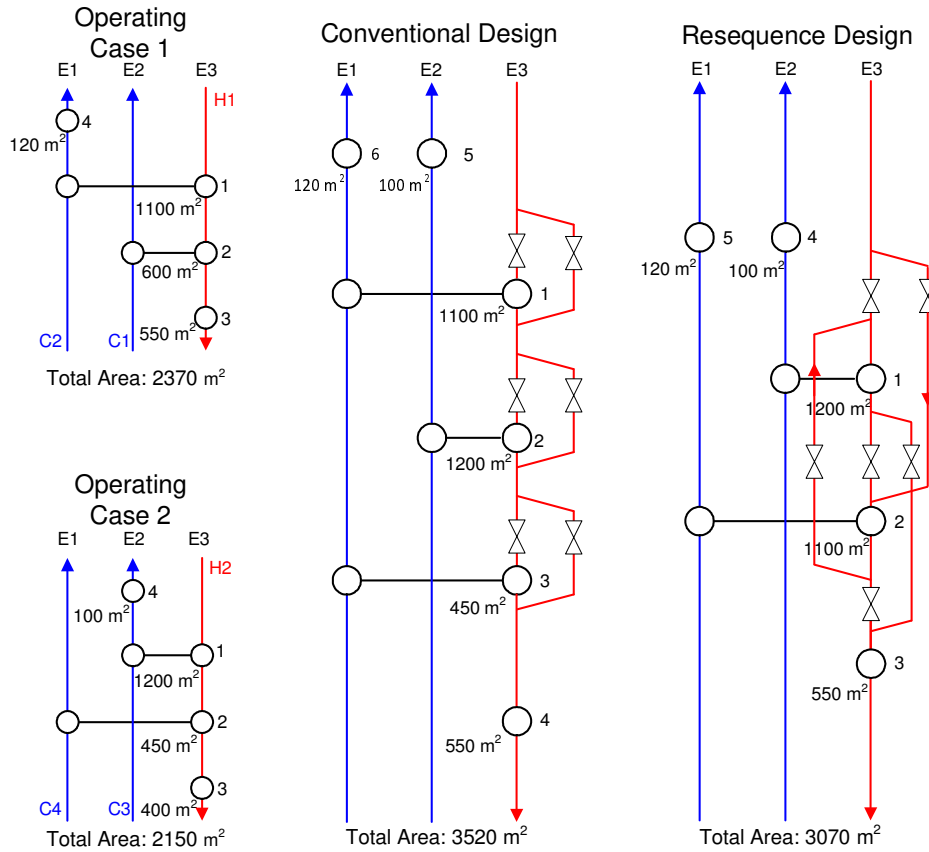

Fig. A.27: Simple two operating case example illustrating HEN design for conventional and resequence design type constraints.

Conventional Design:

This design type is the variant that has the least flexibility. The HEXs in the overall design must always maintain the same matches between the same two streams as given in the original OCs. In addition the HEXs must be so placed that each stream of the HEX flows in the same order as in the OCs (see figure A.27). Based on these restrictions the condition arises that per stream always only one HEX for all OCs can be reused.

Resequence Design:

By resequence design, as by conventional design, the HEX between the same two streams must be maintained between the OCs. However, in contrast to conventional design it is allowed in resequence design to have the flow in any order for each stream. As a result, the HEX area can be placed in a more flexible manner and the total HEX area of the overall design will be smaller than by conventional design. For example, for OC 1 in the overall

design shown in figure A.27 stream H1 first flow through HEX 2 and then via bypass back to HEX 1 and then finally through HEX 3. Through the use of several bypasses can the stream H1 be redirected in very flexible manner.

The more flexible the HEN design then the greater potential for the reuse of HEX area between OCs, but as a result a larger investment in piping, valves and control system needs. These costs must also be considered in the analysis.

Calculation Of Combined Supertargeting Optimization:

Both the conventional and resequence design supertargeting use a two loop during calculation:

- Inner Loop: Searches for the set of ΔT_{min} for each OC which results in the lowest total cost
- Outer Loop: Searches for given set of ΔT_{min} for the maximum common HEX area and therefore the minimal total HEX area needed for the overall network

Based on the assumption of vertical heat transfer (as assumed in the area **target** calculation based on the composite curve), the amount of common or reused HEX area can be calculated and maximized using linear programming. In the case of resequence design, this is done based on the shifting of heat flow (or analogously area) between HEX matches based on loops in the networks. The linear program is able to shift the area in order to maximize the area between each match (i.e. matrix elements shown in figure A.28). A simpler yet similar linear programming approach is also used for conventional design to determine the candidates for heat transfer and the associated maximum areas for each TS/OC. With these new values the total required area **target** is reduced given the greater amount of common area now available.

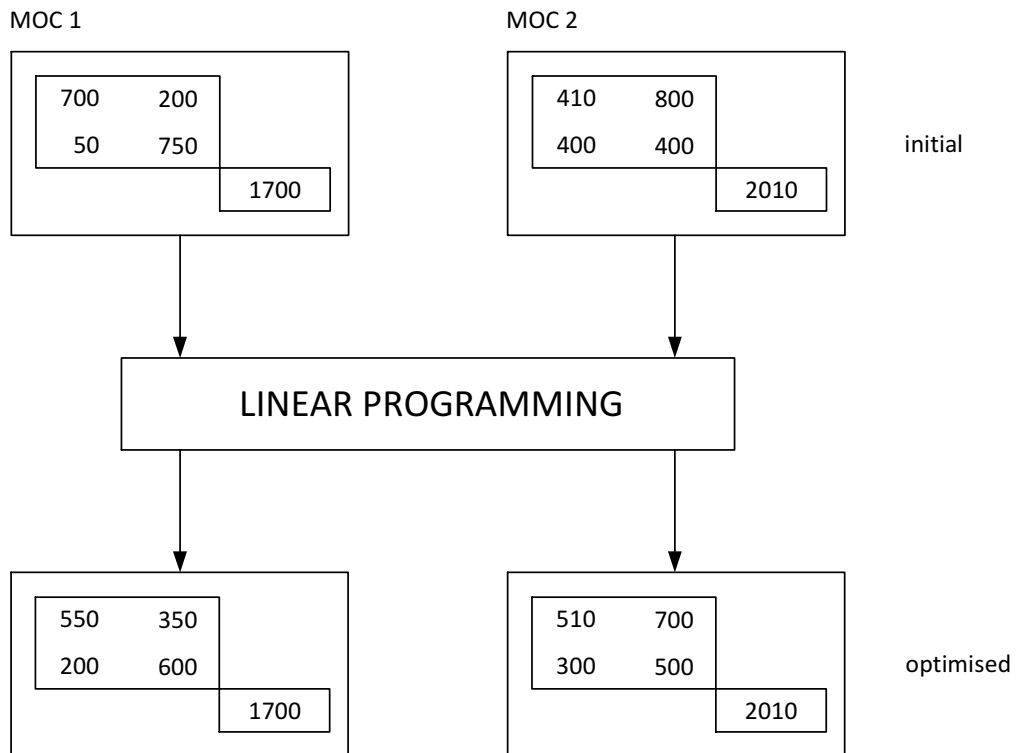

Fig. A.28: Area matrices are optimized simultaneously to increase common area between the operating cases resulting in total minimum area target. This approach is based on the resequence design constraint.

Once the new conventional and resequence design target results have been calculated (and the area matrices, the ΔT_{min} values and other parameters are known), then design of the HEN can be done to approach the values. In addition to area and cost targeting for both conventional and resequence design, the **pinch match matrix** is also used in HEN design to determine which HEX match exists at the pinch point for each TS/OC. These pinch HEXs can be sized based on the area targets to use the largest area and then reused in the other TS/OSs. Support for the design of multiple OCs or batch TSs is included in PinCH 3.2 using the following functionality (see section 12.6):

- Multiple OC/TS Mini Map
- Area/Temperature Calculation Tool
- Export Conventional Design Matrices
- Export Separate Design Matrices

These new functionalities together with the existing capabilities of the PinCH MER and Relaxed HEN design support provide an effective approach to designing an overall HEN flexible enough for the multiple OCs or TSs. For more information on the MOC supertargeting algorithm and MOC HEN design based on the conventional and resequence HEN design types the information given by Jones [16] and by Krummenacher [17] is recommended.

HEN Design Guidelines

There are several general guiding principles involved in MOC HEN Design. They are as follows:

- The MOC HEN design strategy uses the PDM, in that the design starts where the problem is most constrained (i.e. the pinch point). This approach is based on the design philosophy: do the most difficult task first. However, an extension to the PDM is to give priority to common pinch matches (otherwise, if placed later, there is less scope for optimising the use of area because of HEN structural constraints).
- Vertical heat transfer is used for key HEX placement; however, criss-cross heat transfer will be necessary to ensure maximum area reuse. The following relaxation considerations need to be used:
 - Violation of the ΔT_{min} rule.
 - Cross pinch heat transfer may be necessary in certain circumstances. However, it should be avoided if possible.
- The minimization of the total cost is accomplished by minimizing the number of units (tick-off matches), while minimisation of area is only second priority (since the number of matches has a larger effect on costs than the area).

Pinch Match Matrix:

The pinch match matrix is critical in the HEN Design as it identifies immediately the critical and most constrained matches at the process pinch. Setting the ΔT_{min} of each OC allows the identification of which streams exist at the pinch (either on one or both sides of the pinch). Any hot-cold stream match that is possible at the process pinch is called a pinch match. The pinch matches in each OC are determined and then merged into a single overall Pinch Match Matrix (See section 12.6 on how to export the Pinch Match Matrix for a conventional design target).

After Combined supertargeting for multiple OCs or batch TSs, the cost-optimum slice-wise pinch ΔT_{min} , the pinch temperature and the cold and hot utility targets are known for each time slice, allowing for the initialization of the grid diagrams of the batch HEN (one grid diagram for each OC or TS). MBC design guidelines aim at the optimal re-use of HEX area (units) across time slices (i.e. the best possible way of utilising capital across time slices).

In conventional, the HEX units remain between the same two streams during the operation of all OCs or TSs. As in the standard Pinch Design Method, the placement of HEX matches begins at the pinch (the pinch matches, i.e. matches present at the pinch, are the most difficult matches to place because of the tight temperature driving forces in this region) and proceeds away. Priority should be given to HEX matches which are used in the largest number of OCs or TSs.

The Combined supertargeting conventional design HEN design procedure involves the following main steps [17]:

1. Identify the possible pinch matches, and select the match concerning the largest number of time slices (build a Pinch Match Matrix).
2. Determine the maximum possible area to be installed for this match (In conventional design this is calculated per Operating Case or Time Slice for maximum area that can be installed between each possible match between an equipment with a hot stream and an equipment with a cold stream [17]).
3. Place match on the time slice requiring the largest area (calculated assuming vertical heat transfer). In some cases, it might be beneficial to install a largest area to form a tick-off match in order to minimize the total number of units (either for the time slice under consideration, or for another time slice).
4. Re-use the largest fraction of the installed area during the other time slices, even if the maximum area calculated assuming vertical heat transfer should be exceeded.
5. Verify the effectiveness of the placement adhering to the vertical model by checking the driving force plot.
6. Apply the above steps for the other HEX matches, until the target temperature of every stream is satisfied during all time slices.

7. Resort to relaxation based on loops and paths to improve the economics. Keep as much as possible the same structure across all OCs or TSs.

When placing the matches, it is recommended to develop similar matches structures in the different time slices in order to minimize the required number of valves and by-pass and to maximize the number of re-used matches. For a conventional design, it is actually possible to use more than one common match on each stream, a possibility which should be exploited[17].

The overall HEN is obtained by merging of the slice-wise HENs , and adding the valves and by-pass to change the sequence of matches according to the requirements of each time slice.

For a conventional design, the candidate matches should be placed in priority; however, cases exist in which the priority placement of candidate matches with both streams present at the pinch is not suitable. In these cases, the selection of the most constrained matches is governed by the following additional priority rules (decreasing order of priority):

1. Candidate matches being pinch matches in the largest number of OCs.
2. Non candidate pinch matches.
3. Candidate matches not being pinch matches.
4. Non-candidate matches that appear (based on the analysis of the HEN structure) to be re-useable because of similar HEN structure
5. Non-candidate non pinch matches.

A.10 Single Batch Product Scheduling and EROP Details

Scheduling Details

Schedules are used to configure the time dependency of either continuous or batch processes. This step is important in ensuring the correct operational times and the resulting operational costs are calculated.

Scheduling of Batch Processes

Batch processes that have a fixed and repeatable schedule are defined by the time dependence of the individual streams according to their specific start and end time. These start and end times define the existence time of each stream relative to the other streams. A Gantt chart can be used to conveniently display the streams and see the individual time slices that are created. These time slices represent time periods where direct heat recovery is possible between the streams that are present. The following diagram illustrates the time dependence typical of a repeating single product batch process:

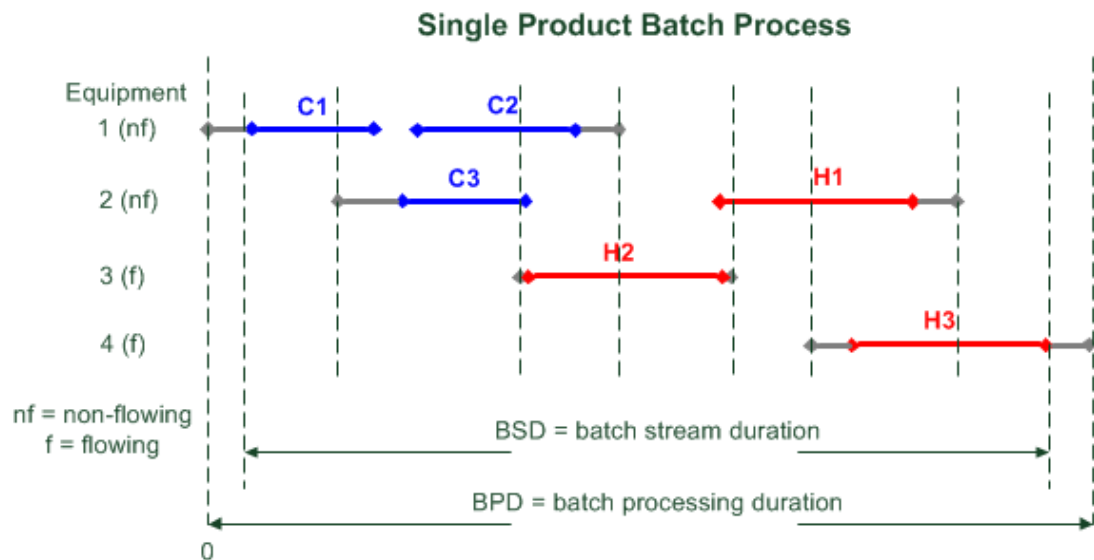

Fig. A.29: Gantt chart of a single product batch showing the existence times of each stream and the piece of equipment they are assigned to. Any equipment pre-processing and post processing times are also shown before and after each stream.

The above diagram shows the relationship between the streams and their relative position to each other in time. Of particular importance is that more than one stream can belong to the same piece of equipment (e.g. in a reactor). These streams are defined as non-flowing given they are contained in a single vessel during their heating or cooling duration. Flowing streams represent the more typical transfer of mass from one point to another such as in a pipe. The duration of the single batch is defined based on the consideration of the pre-processing or post-processing of the equipment items themselves. Two types of duration are shown on the diagram and are defined as follows:

- BSD - Batch Stream Duration
- BPD - Batch Process Duration

The batch stream duration is determined by the existence times of the stream themselves and define the time slices for direct heat integration. However, the actual availability of each piece of equipment is limited by any pre or post processing required for each batch giving an overall batch process duration.

The analysis of the single batch is important for heat integration; however, it is often the case that the individual batches are overlapped to increase production. This overlap provides the possibility to transfer heat between different batches. As a result, an equipment-wise repeat operation period (EROP) can be identified representing a new set of time slices. The following diagram illustrates a one day Base Production Cycle (BPC) consisting of four overlapping single batches and the resulting EROP that forms two times over the 1st, 2nd and 3rd stream-wise repeat operation periods (SROP). In addition, equipment 2 is shown to be doubled (E2.1 and E2.2) due to the overlap in time with itself based on the given BCD. This is not possible in reality and as a result the second piece of equipment E2.2 has to be included.

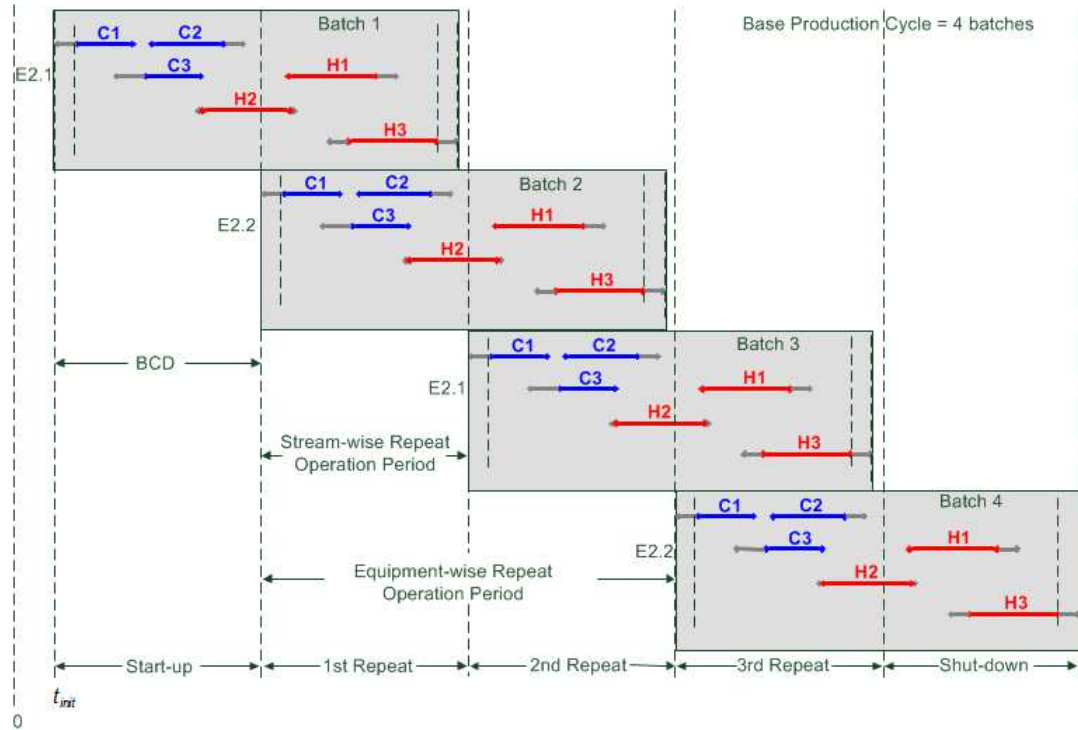

Fig. A.30: Example of the how the equipment-wise repeat operation period (EROP) forms given a base production cycle (BPC) consisting of four overlapping batches.

Equipment-wise Repeat Operation Period (EROP) in the PinCH Software

The PinCH software automatically calculates the EROP based on the amount of overlap defined in the schedule. The key parameter to define the amount of overlap is the Batch Cycle Duration (BCD), which is the time at which the next batch starts after the previous batch has started. The following diagram shows how a single product batch process that is overlapped in time is visualized in the PinCH software. The equipment E1.1 is shown to have two streams assigned to it. Given the amount of overlap of consecutive batches, the situation arises whereby the pieces of equipment E1.1 and E2.1 overlap with themselves in time. As a result, the software automatically increases the number of pieces of equipment for E1.1 and E2.1 to two as would be done in practice. The additional heat transfer area and operational costs are accounted for automatically in targeting as the number of pieces of equipment are increased.

The startup and shutdown phases represent the time periods just before the first EROP begins and just after the last EROP is complete. Since no overlap occurs during these time periods no direct heat transfer between batches can occur and typically hot and cold utilities would be used meet the process requirements.

The operational costs of the startup and shutdown phases can be significant if the number of base production cycles (BPC) are large. PinCH focuses on just the repeated operation periods and does not account for the startup and shutdown costs in the total cost. If the user would like to analyze the startup and shutdown phases (i.e. time slice decomposition, composite curves, heat recovery, cost, etc.) then each phase will have to be defined separately as a single batch with a batch cycle time (BCD) large enough so that no overlap occurs.

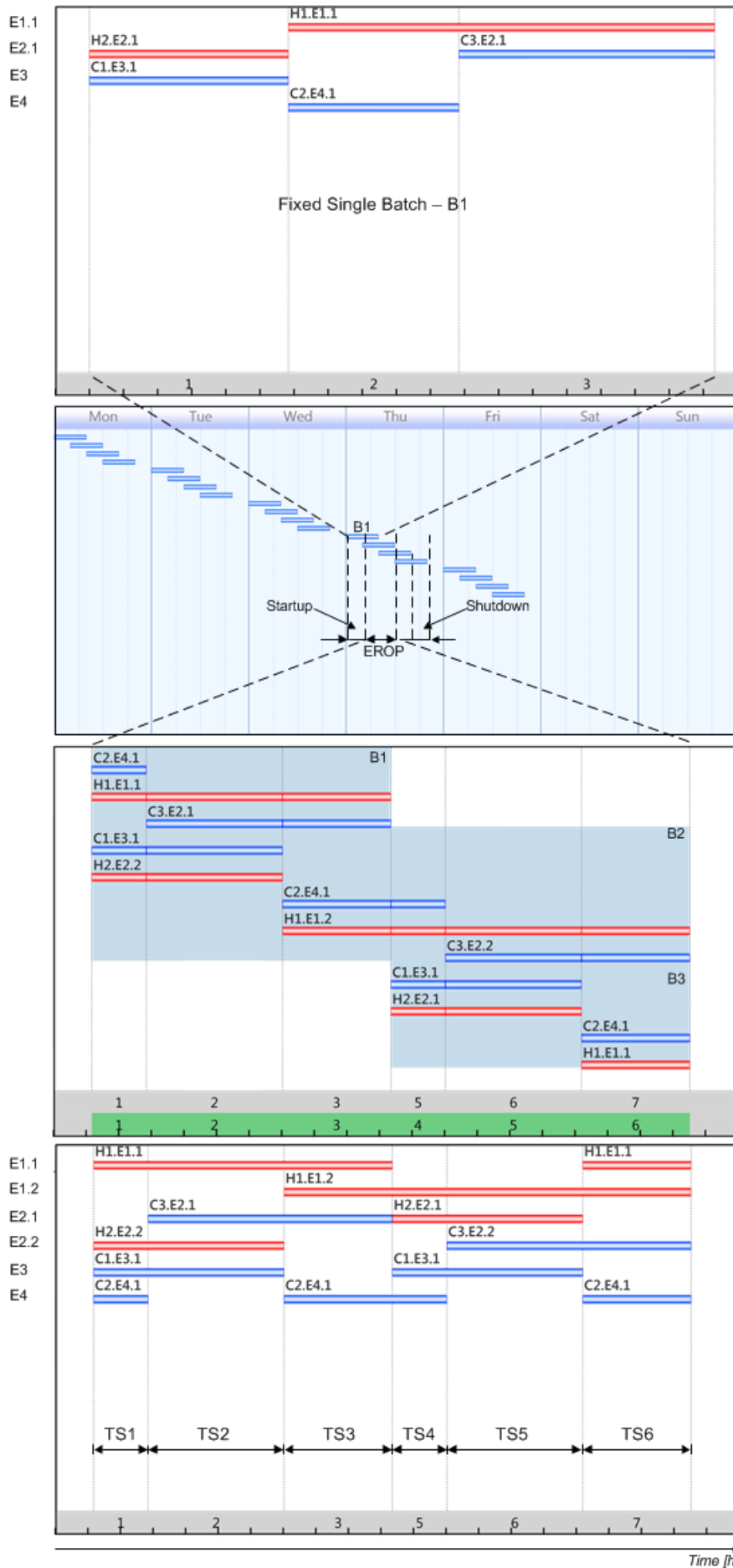

A.11 Indirect Source and Sink Profile

The Indirect Source and Sink Profile (ISSP) is used to determine the indirect heat recovery potential of a batch process. Indirect heat recovery is achieved using intermediate loops (IL) and heat storages (HS) (i.e. there is no direct heat transfer between any of the streams involved in the pinch analysis). This allows the full energy content of a stream to be captured and potentially used for heat recovery, regardless of when the stream occurs in time.

Unlike indirect heat transfer for continuous processes in which an intermediate loop can transfer heat between two streams, with the ISSP analysis heat is always transferred as such:

Heat Source (Hot Stream) \rightarrow Intermediate Loop \rightarrow **Storage** \rightarrow Intermediate Loop \rightarrow Heat Sink (Cold Stream)

There are several differences and considerations between the ISSP analysis and the “classical” analysis. To provide an overview of the topic, these differences and considerations are listed next. Afterwards, each of the points will be discussed in greater detail.

1. Time period of analysis and scheduling of the batch process
2. Representation of the ISSP in kWh
3. Formulation of the stream tables
4. Stream specific $\Delta T_{min,s}$ (or Time Slice CC specific $\Delta T_{min,s}$)
5. Heat storage possibilities
6. Placement of the IL/HS; no HEN design required

For this section these items will be divided into the following two categories: **Constructing the ISSP** and **Thermal Energy Storage Design**. Items one to four will be discussed in Constructing ISSPs and five and six will be discussed in the Thermal Energy Storage Design section. After reading the following section, the significance of the ISSP and how they are constructed should become clear to the reader.

A.11.1 Constructing ISSPs

Time and scheduling of the batch process

The time period of interest for the ISSP analysis is normally the length of one batch. However, there are two different approaches to constructing the ISSP dependent on the type of scheduling of the process. The two types of scheduling that affect the ISSP are *fixed* and *variable* scheduling:

- Fixed Schedule (the batch process strictly adheres to its schedule with very little variation)
 - The CCs are constructed for the *individual time slices* and these curves are then used to construct the ISSP based on the cascade residuals derived from the GCC i.e. direct heat recovery and indirect heat recovery are considered concurrently (see Section 9.4).
 - This ISSP-GCC based graphic is not discussed in this section.
- Variable Schedule (the timing of the batch process and its streams can change)
 - All the *streams* involved in the analysis are included in the either the source or sink profile.
 - This ISSP-Stream based graphic is reviewed in detailed below.

Representation of the ISSP in kWh

The enthalpy content of the ISSP, like the Time Average Model (TAM), is represented in kWh and not in kW. This is due to the streams being represented in their entirety, regardless of the time the stream occurs, and not for a specific moment in time.

Formulation of the stream table

The stream table for the ISSP is similar to the stream table for direct heat transfer except with four alterations, which are listed next and can be seen in Table A.11:

- Shifted Temperatures (T^*) – The temperatures shown in the ISSP stream table have been shifted (hot streams down and cold streams up). This is discussed further in the section on $\Delta T_{min\ s}$.
- Mass – In addition to the mass flow of a given stream, the mass should now also be shown. This can be calculated with:

$$m_s = \dot{m}_s \cdot (t_{end} - t_{start}) \quad (A.1)$$

m_s	[kg]	mass of stream s
\dot{m}_s	[kg/h]	mass flow of stream s
t_{start}	[h]	start time of stream s
t_{end}	[h]	end time of stream s

- Enthalpy Content – The enthalpy content of the stream is shown in kWh and not in kW. This is calculated as follows:

$$E_s = \dot{m}_s \cdot c_{p,s} \cdot (T_{s,end} - T_{s,start}) \cdot (t_{end} - t_{start}) \quad (\text{A.2})$$

Combining A.4 and A.5

$$E_s = m_s \cdot c_{p,s} \cdot (T_{s,end} - T_{s,start}) \quad (\text{A.3})$$

E_s	[kWh]	energy content of stream s
$c_{p,s}$	[kJ/kgK]	specific heat capacity at constant pressure of stream s
$T_{s,start}$	[K]	the starting temperature of stream s
$T_{s,end}$	[K]	the ending temperature of stream s (As only the temperature difference is necessary, the shifted temperatures can also be used to calculate the energy.)

- Stream specific $\Delta T_{min s}$ – the last column on the right; it will be further discussed next.

Table A.11 is an excerpt of the full stream table for the ISSP shown in Figure A.32.

Tab. A.11: ISSP Stream Table

Stream	T_{in}^* [°C]	T_{out}^* [°C]	m [kg]	\dot{m} [kg/s]	c_p [kJ/kgK]	α [W/(m ² K)]	t_{start} [h]	t_{end} [h]	Energy [kWh]	$\Delta T_{min s}$ [K]
C1	25.5	75.5	11'000	6.111	4.00	500	0.00	0.50	611.2	15.5
C2	118.4	119.4	10'000	1.282	705.90	2'000	3.08	5.25	1'960.8	3.4
H1	108.0	107.0	4'500	0.577	699.98	4'000	3.08	5.25	-875.0	3.0
H2	105.8	45.5	3'000	0.385	2.00	1'000	3.08	5.25	-100.0	4.2

Stream specific $\Delta T_{min s}$

The following discussion relates to the calculation of the stream specific $\Delta T_{min s}$.

Two important considerations regarding the temperature levels of the streams involved in the ISSP are:

- Each stream has been designated and shifted by a unique ΔT value know as $\Delta T_{min\ s}$.
- The temperatures of the streams have been shifted by the $\Delta T_{min\ s}$ value either up for cold streams or down for hot streams.

Designating a specific $\Delta T_{min\ s}$ to each stream in the analysis allows for an objective, energetic comparison of all the streams. This is especially useful if after the initial analysis it is decided that certain streams should be excluded from the ISSP.

The formula for calculating $\Delta T_{min\ s}$ is:

$$\Delta T_{min\ s} = f_p \left(\frac{1}{k_{sk}} \cdot \frac{1}{d_s} \right)^y \quad (\text{A.4})$$

$\Delta T_{min\ s}$	[K]	Temperature shift of stream s
f_p		Constant of proportionality
k_{sk}	[W/(m ² K)]	Overall heat transfer coefficient between stream s and IL k
d_s	[h/a]	Duration of stream s within an EROP per year
y	[-]	Bandwidth exponent

The exponent y is chosen by the user and limits the range of the $\Delta T_{min\ s}$ values. A typical default value for y is ca. 0.9.

To calculate the constant of proportionality the following formula can be used:

$$f_p = \text{Max}_s[(k_{sk} \cdot d_s)^y] \cdot \Delta T_{min, ov} \quad (\text{A.5})$$

$\text{Max}_s[(k_{sk} \cdot d_s)^y]$	The value of $(k_{sk} \cdot d_s)^y$ is calculated for each stream. The maximum of these values is then used to calculate f_p .
$\Delta T_{min, ov}$	This is the minimum $\Delta T_{min\ s}$ value used in the ISSP. It must be determined prior to calculating the constant of proportionality and must be assigned to at least one stream.

The overall heat transfer coefficient k is calculated as follows (this is a simplified calculation):

$$k_{sk} = \frac{1}{\frac{1}{\alpha_s} + \frac{1}{\alpha_k}} \quad (\text{A.6})$$

α_s	$[W/(m^2K)]$	Heat transfer coefficient of stream s
α_k	$[W/(m^2K)]$	Heat transfer coefficient of IL k

As stated previously the stream specific $\Delta T_{min\ s}$ value allows for an objective and energetic comparison of the streams. From Formula A.4 it can be seen that streams with low heat transfer coefficients (low α_s) and short durations (short d_s) will have a greater $\Delta T_{min\ s}$. Thus, these streams provide less heat for IHR and therefore are of less benefit.

Constructing the ISSP

Once all the above information is known and the stream shifting has taken place, the ISSP can be constructed. This is done analogously to constructing the composite curves for continuous processes, however, the construction of the ISSP takes place in the T, H diagram and not in the T, \dot{H} diagram. The combining of the hot streams makes up the Indirect Source Profile and the combining of the cold streams makes up the Indirect Sink Profile. An example of a constructed ISSP can be seen in Figure A.32.

Notes:

- The abscissa axis is in kWh and the ordinate axis shows the shifted temperature.
- The ISSP is based on the Stream Repeat Operation Period (SROP) and not the Equipment Repeat Operation Period (EROP). As a result, the ISSP is from an energy perspective the same as the original batch process without overlap. However, the design of the HESN schema and associated HEX costs account for additional pieces of equipment as shown on the HEN schema.
- The individual streams are added to the ISSP. These are indicated by the red horizontal lines above the Indirect Source Profile and the blue horizontal lines below the Indirect Sink Profile. Each stream has been named: For the hot streams the names are indicated by H1-H5 and for the cold streams C1-C6.

The addition of these streams only indicate the shifted start and end temperatures of the streams, they are in no way indicative of the energy content of the streams.

To determine the shifted temperatures of the individual streams, simply draw vertical lines from the end points of the arrows to the corresponding profile, i.e. hot streams to source profile and cold streams to sink profile. An example of this can be seen in Figure A.32 for streams H5

and C3 (see the black dashed lines). Thus, stream H5 has temperatures of $T_{in}^* = 64.5^\circ\text{C}$ and $T_{out}^* = 14.5^\circ\text{C}$, whereas C3 has $T_{in}^* = 27.6^\circ\text{C}$ and $T_{out}^* = 90.6^\circ\text{C}$.

- When vertical sections of the ISSP are in contact with each other a small minimum energy limit is assumed to avoid issues where the IL calculation at boundaries where Ts and projections are at same enthalpy but not at same temperature (e.g. can result in HEXs shown with $\text{HR} = 0.001 \text{ kWh}$ on HEN Schema).

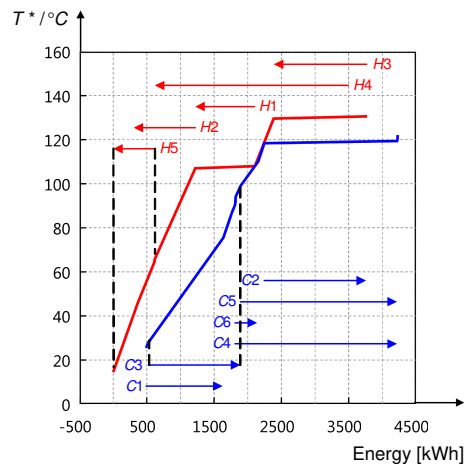

Fig. A.32: Indirect Source and Sink Profile

A.11.2 Thermal Energy Storage Design

Heat Storage Possibilities

As previously stated, the ISSP considers only indirect heat transfer with thermal storages. This next part is a brief overview of the different types of thermal storages that are available in PinCH. For storage possibilities a distinction between two physical principles can be made:

- Latent Heat Storages – A phase change occurs in the storage medium. Normally, *solid* \Leftrightarrow *liquid* or *liquid* \Leftrightarrow *gas*
- Sensible Heat Storages - The storage medium does not undergo a phase change. Typically, *solid* or *liquid* mediums are used.

Pinch 3.2 allows for the integration of two types of sensible heat storages. They are:

1. Stratified Storage (Figure A.33 (a))
2. Fixed Temperature Variable Mass (FTVM) Storage (Figure A.33 (b))

Stratified heat stores have the advantage that only one heat storage tank is required per IL, whereas the FTVMs require 2 storage tanks per IL. This leads to higher investment costs for the FTVM systems.

Due to technical reasons stratified storage tanks can only attain a limited temperature difference between the top T_{high} and the bottom T_{low} of the storage unit. FTVM systems can have a much greater temperature difference between the hot tank T_{high} and the cold tank T_{low} than stratified tanks.

As can be seen in Figure A.33, both storage types are divided into two sides, one for charging and one for discharging the storages. Also note that the heat exchangers for both storages are only connected in parallel. A series connection of the heat exchangers is normally not possible due to the non-synchronicity of the streams in the batch process. This means that each stream which contributes to the charging/discharging of an IL must be capable of heating the IL from T_{low} to T_{high} or cooling it from T_{high} to T_{low} .

Placement of the IL/HS; no HEN design required

The placement of the intermediate loops and heat storages takes place directly in the ISSP diagram. This eliminates the need to design a HEN, however, the placement of the ILs and HSs can still be complicated. Figure A.34 will be used to aid in the understanding of how to place the ILs and HSs.

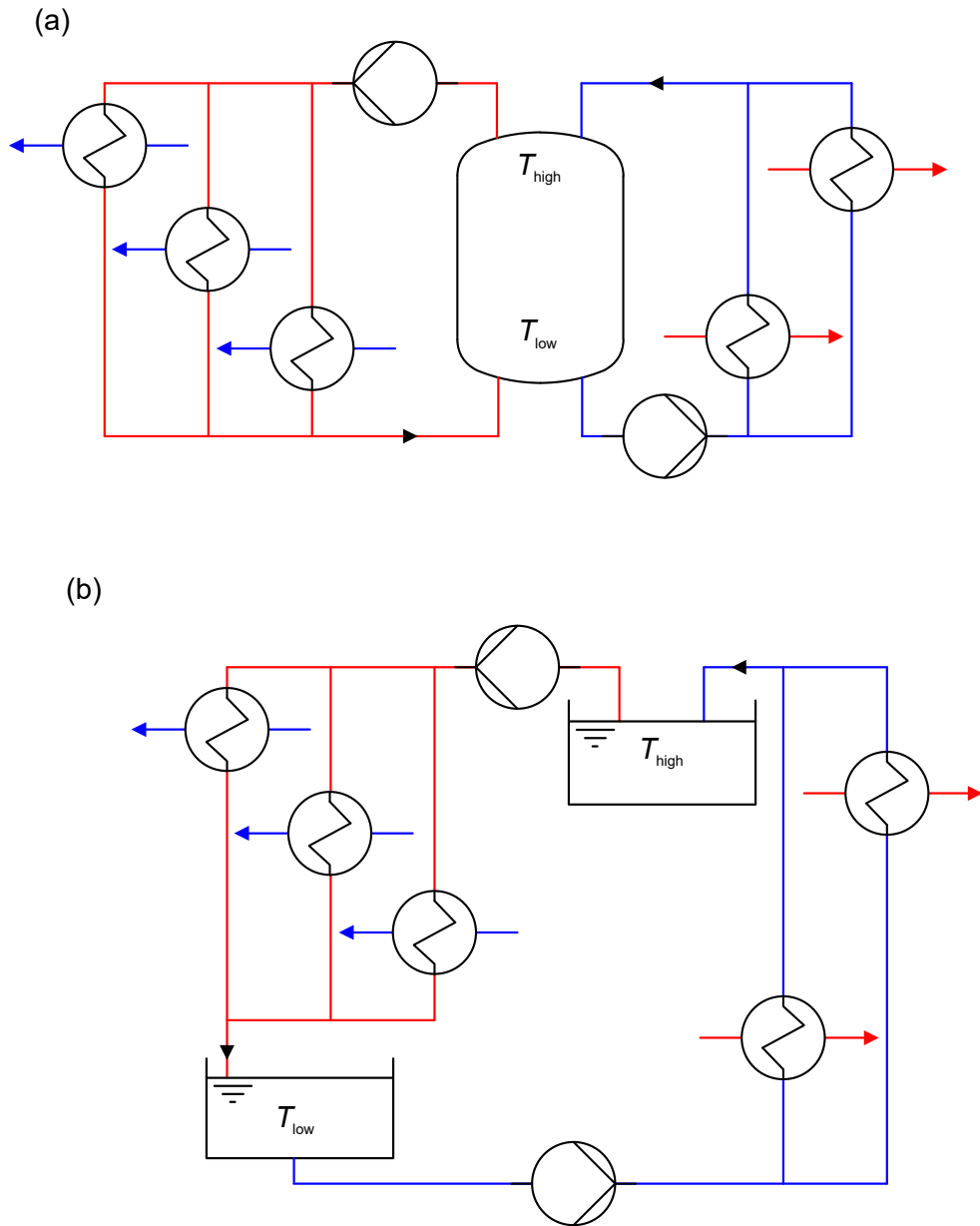

Fig. A.33: Sensible Heat Storages – Stratified & FTVM

The letters a-f indicate the regions in which the ILs and HSs can be placed. The letters 1-5 indicate where the ILs and HSs in this example were actually placed. The black lines show the placement of the ILs with stratified storage and the gray lines show the ILs with FTVM storages. In total five ILs are required in this example. Assuming the black lines correspond to either

stratified tanks or FTVM storages, this design results in five stratified tanks or ten FTVM tanks (Note: It is possible to reduce the number of required FTVM tanks i.e. the grey line, this will be discussed later).

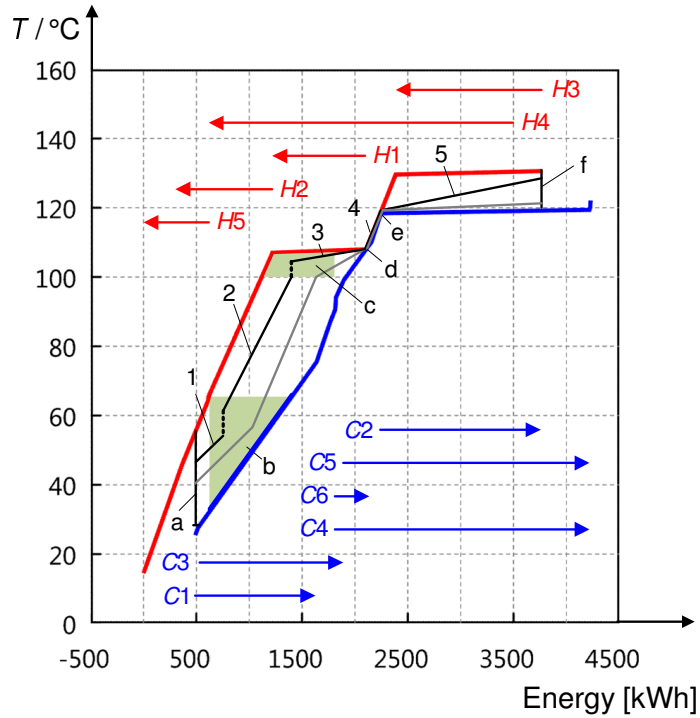

Fig. A.34: ISSP with Placed ILs and Heat Storages

The regions (a-f) can be determined based on the starting temperatures of each stream that create temperature and enthalpy bounds. An underlying algorithm (not described here) is used to determine regions or areas of applicability to place either a high or low temperature layer/tank (called assignment zones). The algorithm always ensures the minimum number of heat storages are required for the given HR. The reader is referred to [19], [20] and [21] for more information.

The placement of the ILs will first be discussed for the stratified storage system (black lines) and then for the FTVM system (gray lines).

IL and Stratified Storage Placement:

- IL 1 – The cold temperature $T_{low,1}$ for IL 1 can be placed anywhere on the vertical line of region *a*, i.e. region *a* is the temperature range in which T_{low} can be placed. The hot temperature $T_{high,1}$ can be placed anywhere within the green area, which is region *b*. This allows the

engineer to freely choose the energy content and $T_{high,1}$, within the constraints of region b , for IL 1.

- IL 2 – $T_{low,2}$ can be placed anywhere on the vertical line running through $T_{high,1}$ in region b . $T_{high,2}$ can be placed anywhere within region c .
- IL 3 – $T_{low,3}$ is chosen in region c based on the same principles as $T_{low,2}$. The placement of $T_{high,3}$ has 0 degrees of freedom and must be placed directly on point d .
- IL 4 – Both $T_{low,4}$ and $T_{high,4}$ have 0 degrees of freedom and are restricted to points d and e respectively.
- IL 5 – $T_{low,5}$ is restricted to point e . $T_{high,5}$ can be placed anywhere on the vertical line, which is region f .

Important: For both the stratified storages and FTVM storages, the temperatures of T_{low} and T_{high} for all the ILs corresponds to the actual temperatures at which the ILs will be implemented. This is because all of the streams in the source profile and sink profile have been shifted by $\Delta T_{min,s}$, i.e. a temperature gradient already exists between the ILs and the source or sink profiles. This also means that the upper and lower temperature of an IL can be placed directly on the source or sink profile and still be valid (IL 4 in Figure A.34 is an example of this).

IL and FTVM Storage Placement:

The placement of ILs with FTVM storages follows the same stipulations as for ILs with stratified storages. However, with the correct placement of the upper and lower temperatures of the individual ILs, the number of required FTVM tanks can be reduced, which also reduces the economic costs for FTVM systems. This can be accomplished by setting the upper temperature of an IL and the lower temperature of the next consecutive IL equal to each other (i.e. $T_{high,n-1} = T_{low,n}$). In this way one FTVM tank can be shared between two consecutive ILs and thus reduce the number of required storage tanks.

As an example, if in Figure A.34 the upper and lower IL temperatures were set such that $T_{high,2} = T_{low,3}$, $T_{high,3} = T_{low,4}$ and $T_{high,4} = T_{low,5}$, then the number of required FTVM tanks could be reduced from ten to six as shown by the grey line.